

AUTOMATION STUDIO™ Educational Edition

The All-in-One Tool of Choice for
Automation, Electrical and Fluid Power
Teaching and Training



✓ Create ✓ Simulate ✓ Troubleshoot
Your Mechatronics Platform

Famic Technologies Inc.



Make Your Circuits Come to Life Through Simulation with Automation Studio™

- Libraries of thousands of 2D CAD symbols ready to simulate, sorted by technologies using international standards (ISO, IEC, NEMA, SAE, JIC, etc.)
- Illustrated libraries to improve connectivity skills for hydraulics, pneumatics, PLCs and electrical (AC, DC, renewable energy, electronics and more)
- All technologies can be linked together to create complete systems, which reinforces students' understanding of system's interactions
- Real looking measuring instruments, such as: multimeter, clamp-meter, oscilloscope, hydraulic tester, thermometer and more
- Create or activate pre-defined failures to develop troubleshooting skills on an electrical, hydraulic or pneumatic circuits, and also to improve PLC training
- Remote access capabilities for e-Learning
- Create custom libraries containing only the required components for specific exercises
- Create a digital twin of your hardware equipment to facilitate the transition from theory to practice
- Ready-to-use 2D and 3D virtual systems
- OPC connectivity to real devices, such as PLCs (Allen Bradley™, Siemens™, LS Electric™, Mitsubishi, etc.), Arduino, Raspberry Pi and others

If you teach subjects related to hydraulics, pneumatics, PLCs, electrical, robotics, instrumentation and process control, and control technologies, the illustration of concepts and the behaviour of systems are no doubt at the heart of your requirements.

Since 1986, Automation Studio™ has proven its strength in technical and engineering educational institutions worldwide by helping students better understand the behaviour and interaction of technologies with an intuitive visual learning approach before moving on to the hands-on trainers.

Automation Studio™ fits multiple programs, such as:

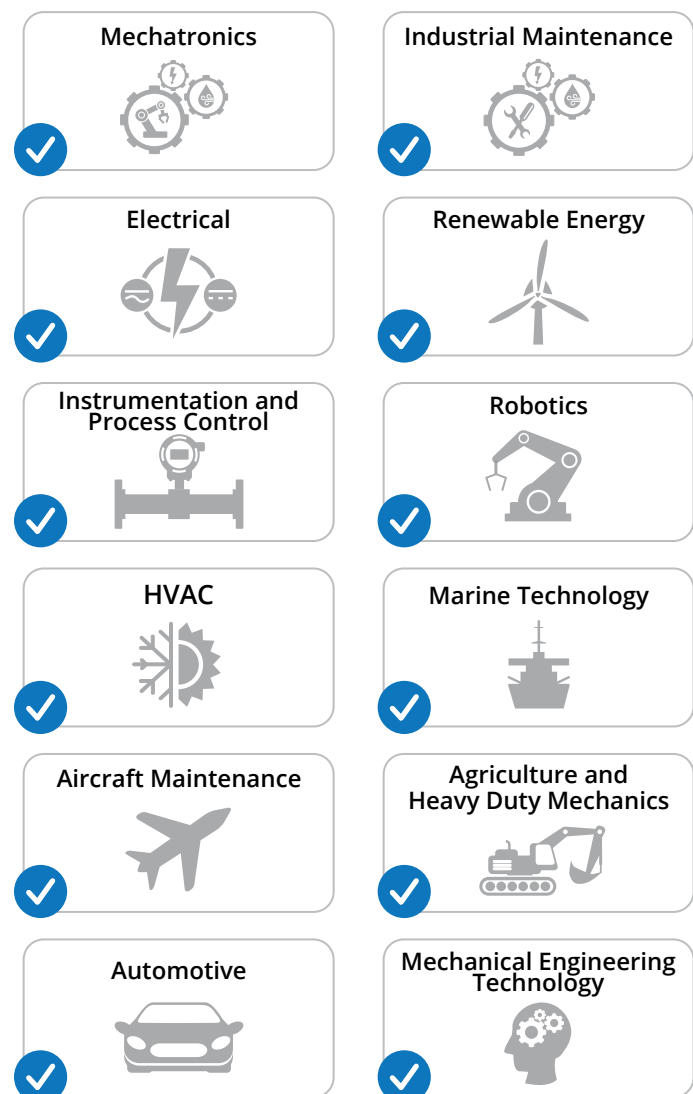

All-in-One Software Solution for Teaching Future Technicians and Engineers

> High School

> Technical Training

> Community Colleges

> Universities

> Workforce

> Corporate Training

Table of Content

- 02 General Overview**
Introduction to Automation Studio™
- 04 Technologies**
General overview of all the technologies implemented in Automation Studio™
- 06 Virtual Trainers**
Premade virtual trainers in all technologies, ready to be connected.
- 08 Hydraulics and Pneumatics**
ON/OFF, Electro and Proportional
- 10 Electrical**
AC, DC, Motor Controls, Renewable Energy, Residential Electricity and more
- 12 Programmable Logic Controllers**
Ladder logic program based on Allen Bradley™ AB-500 and AB-5000, Siemens™, Mitsubishi, LS Electric™ and IEC61131-3
- 14 Robotics**
4 and 6 axis Robots
- 16 Instrumentation & Process Control**
Temperature, level and flow control
- 18 SFC and Structured Text**
Sequential Function Chart (SFC) / GRAFCET, Structured Text
- 19 2D and 3D Virtual Systems**
Conveyors, traffic lights, elevators, pick and place, and more, ready to be controlled
- 20 Manufacturers' Catalogues**
Real life component behaviour that includes PDF specifications and test benches
- 21 Electrical Controls / Digital Electronics**
*Relay logic circuits (JIC and IEC)
Logic gates, flip-flops, decoders and more*
- 22 Block Diagram**
Mathematical models using function blocks
- 23 3D Multibody Dynamics**
Build, Simulate, and Understand Mechanical Systems
- 24 Teachware**
Premade exercises for hydraulics, pneumatics and electrical, with basic physics introduction
- 25 e-Learning**
From anywhere, create videos, share documents, projects and more
- 26 Connectivity**
Exchange input/output signals with real PLCs, Arduino, Raspberry Pi or any devices that are OPC compatible
- 27 Industry 4.0**
Andon Studio™ to collect data, trigger alarms, edit workflows and more

➤ Electrical AC/DC

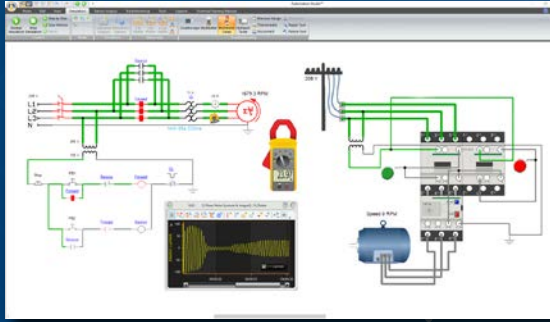

➤ Electrical Controls

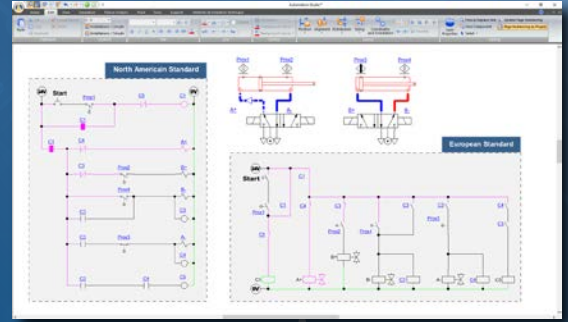

➤ Pneumatics

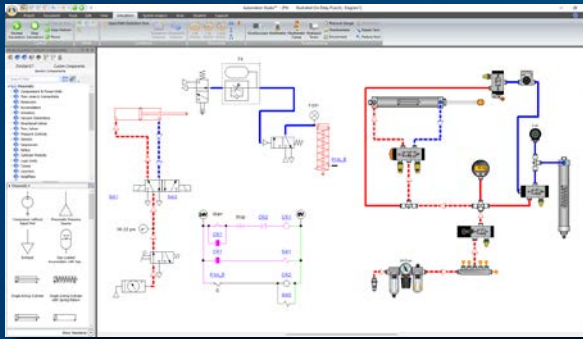

➤ 3D Multibody Dynamics

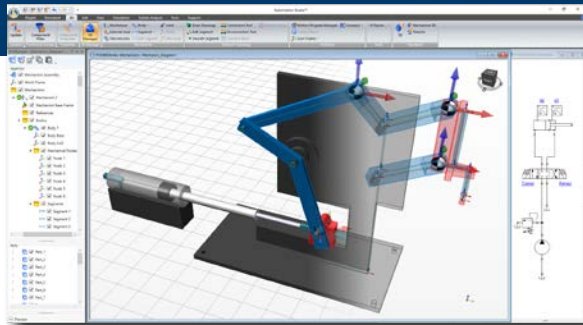

➤ Hydraulics

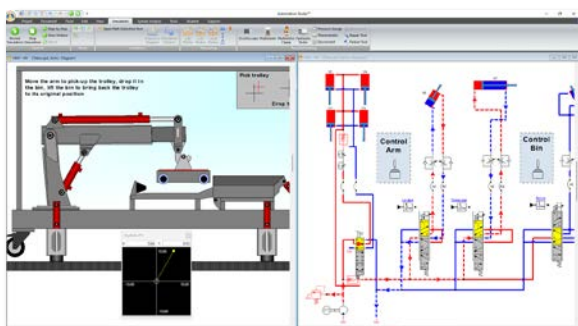
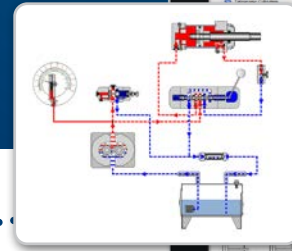

➤ HMI 2D/3D Control Panels

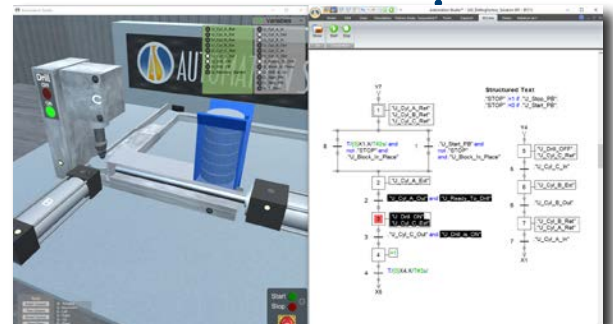

➤ Sequential Function Chart (SFC) / GRAFCET, Structured Text

➤ Robotics

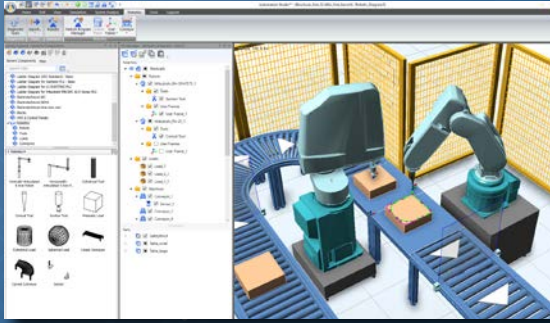

➤ Instrumentation and Process Control

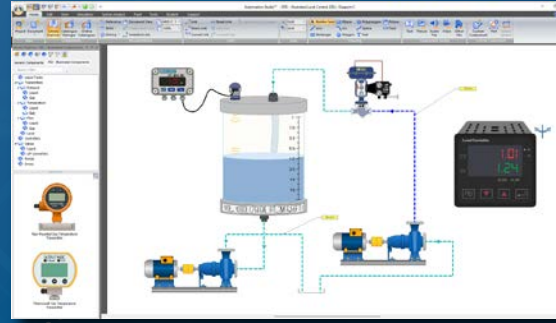

➤ Programmable Logic Controllers (PLC)

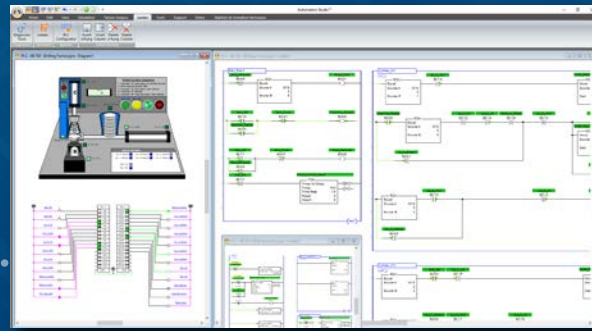

➤ Digital Electronics

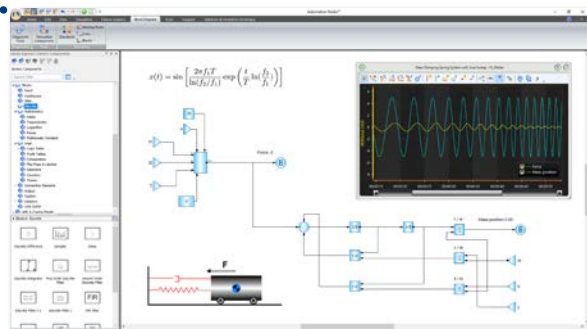
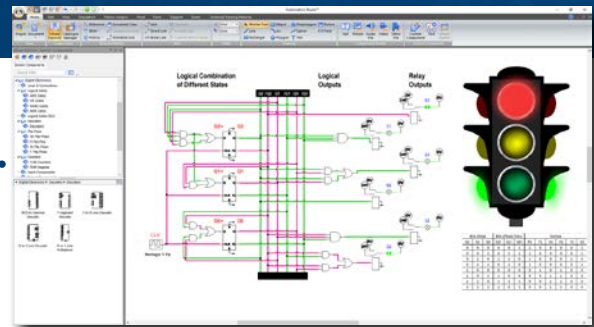

➤ Block Diagram-Math

➤ Electrical One-Line

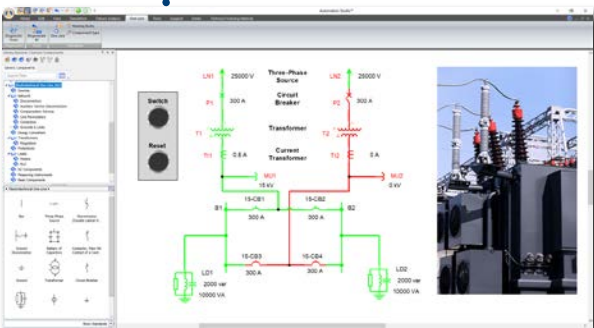

ATION STUDIO™

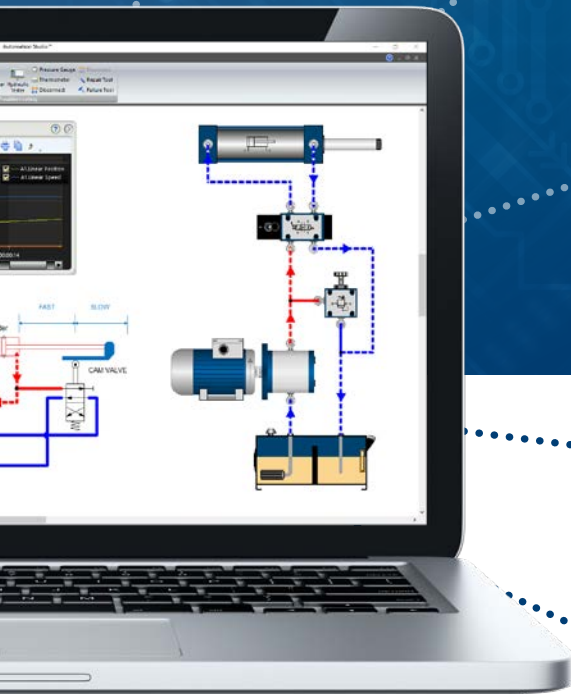

- Create ✓
- Simulate ✓
- Troubleshoot ✓

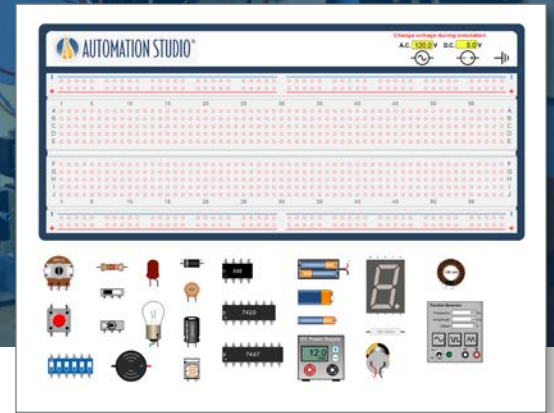
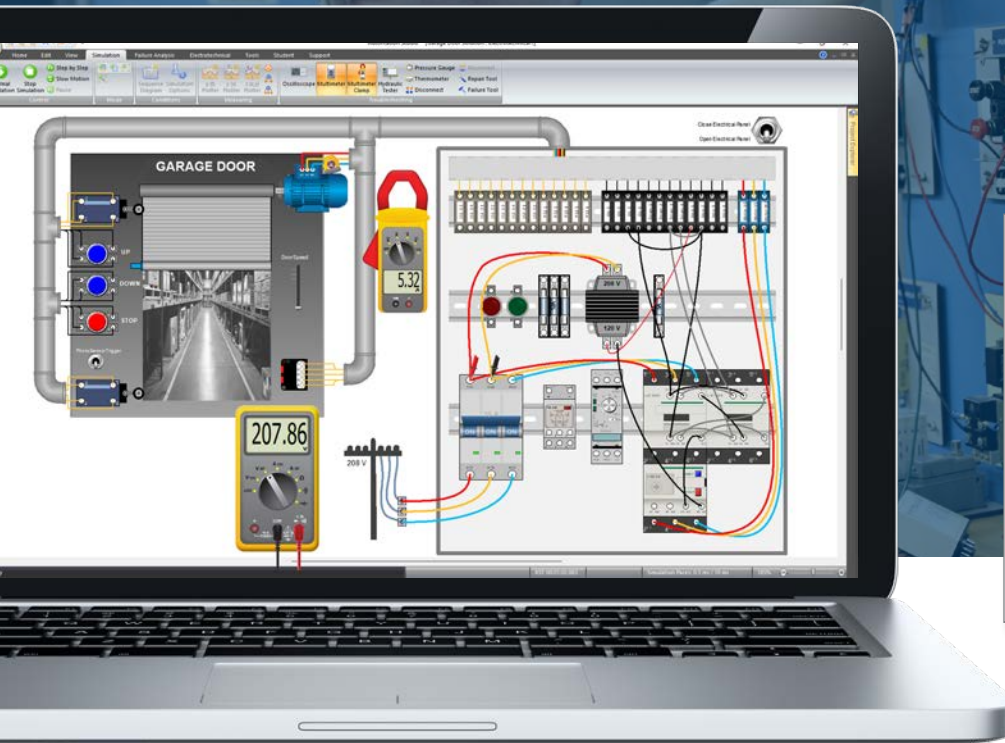

Premade Virtual Trainers in all Technologies, Ready to be Connected!

Select from over 40 premade virtual trainers and rapidly start making connections. These virtual trainers can also be modified to create digital twins of your hardware trainers using the illustrated libraries.

Virtual trainers offer a different approach to introduce students to different connection scenarios. Therefore, some virtual trainers use banana cables where symbols are visible, like on most of the educational hardware trainers, and others use a more realistic approach where students wire true to life components. This will strengthen students' wiring and troubleshooting skills.

Flexible links will automatically be activated for these virtual trainers. They will offer banana cable appearance or a regular wire appearance, depending on the selected template. In addition, after making a connection, users can select the type of link. For example, on the Residential Electricity Virtual Trainer, hot, neutral and ground wires can be selected.

Basic Electrical

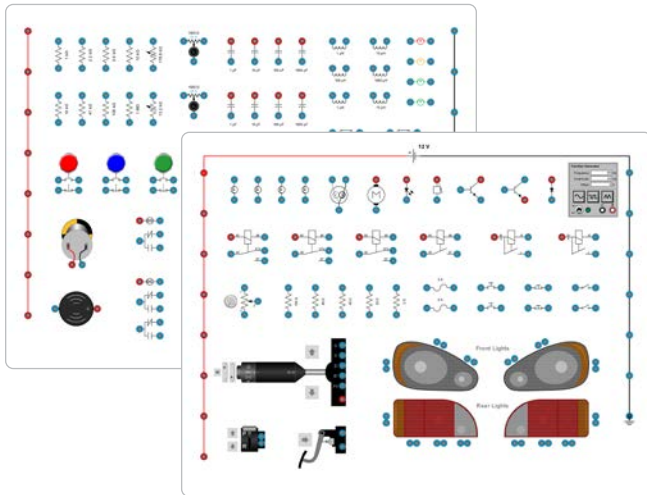

Electro-Pneumatic / Hydraulic

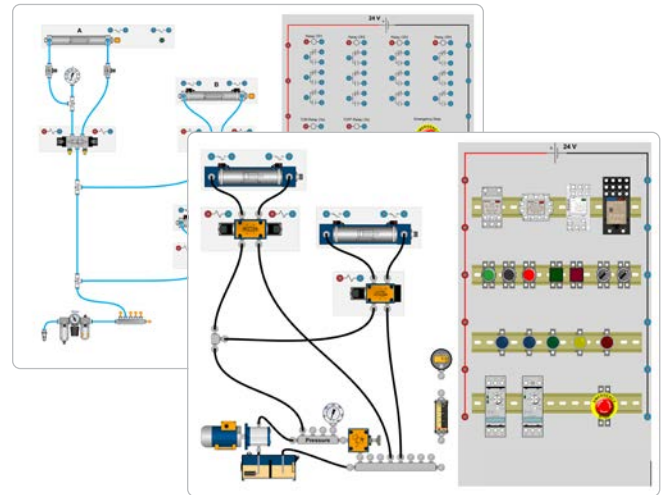

Relay Logic

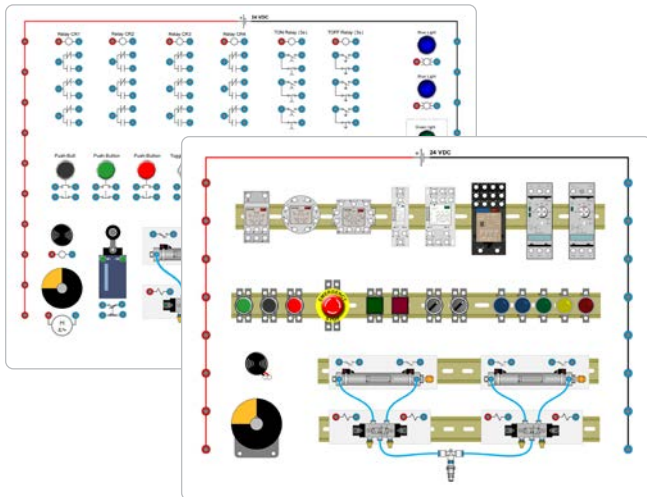

PLCs

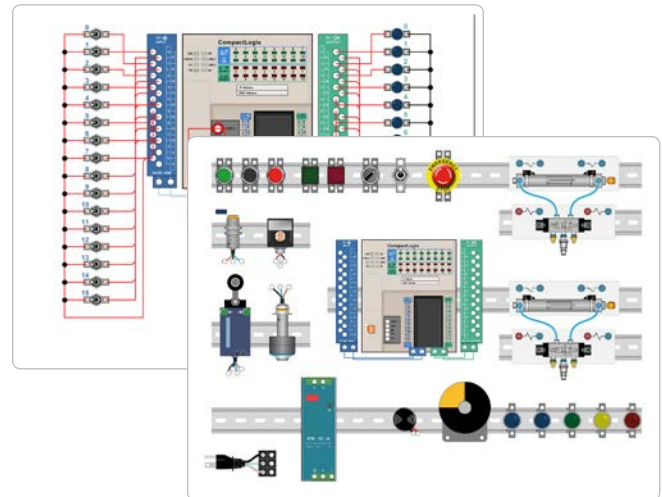

Renewable Energy / Residential Electricity

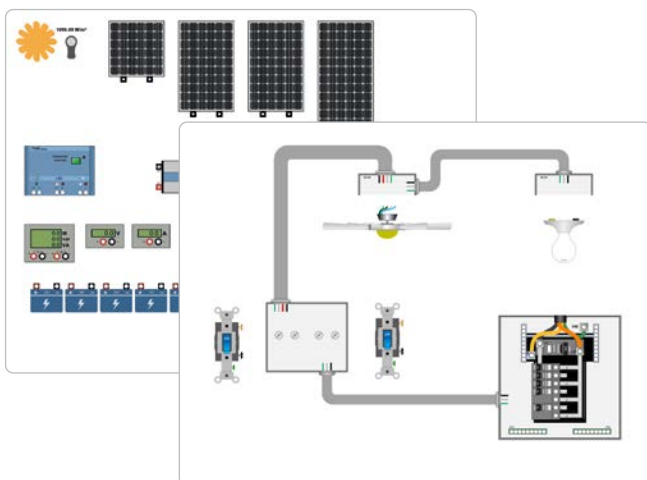

Motor Control

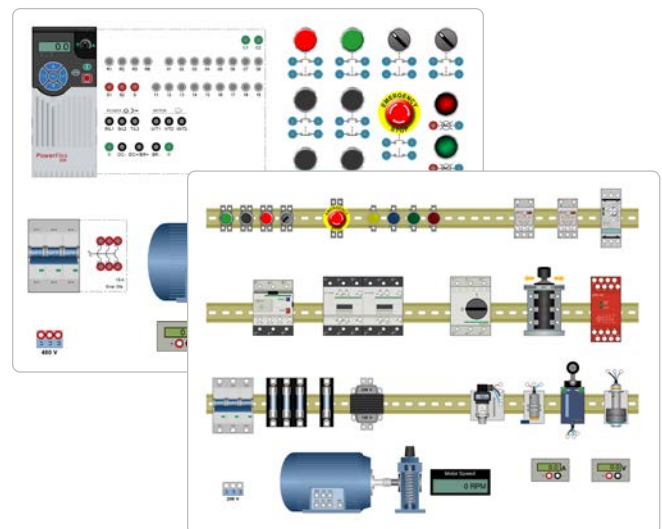

Hydraulics and Pneumatics

- Create ✓
- Simulate ✓
- Troubleshoot ✓

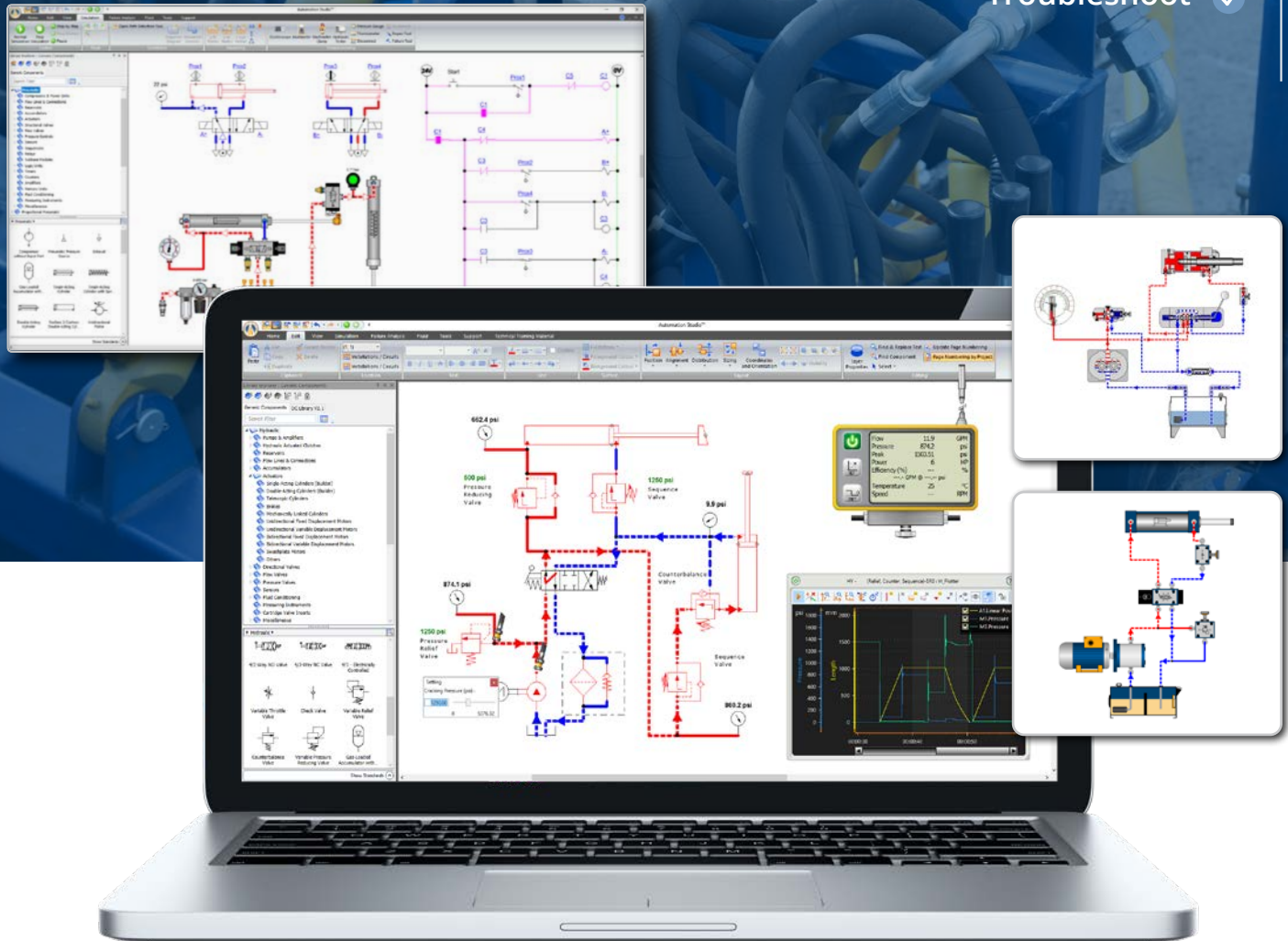

The Best Solution to Reproduce Hydraulics and Pneumatics Lab Assignments That Fit Your Curriculum

The Hydraulics and Pneumatics libraries are compliant with ISO 1219-1:1991/2012 and 1219-2:1991/2012 standards. With Automation Studio™, you can create, simulate and troubleshoot hydraulics and pneumatics (ON/OFF, electro and proportional) circuits. The software offers a wide array of ISO and illustrated components to create basic to advanced circuits and enables you to create digital twins of your hardware trainers.

Thousands of ISO and Illustrated Components to Choose From

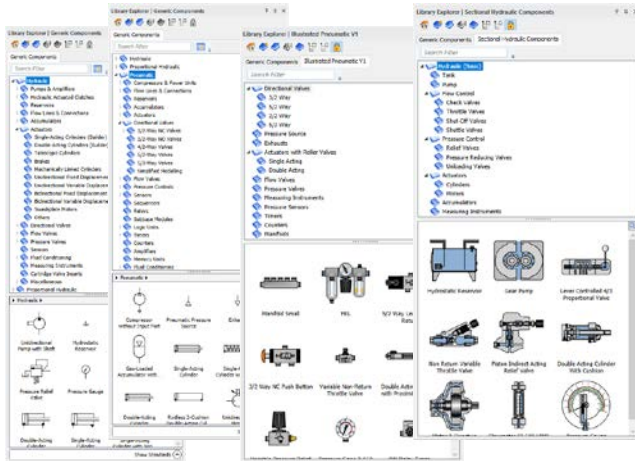

Create Custom Libraries That Fit Your Needs

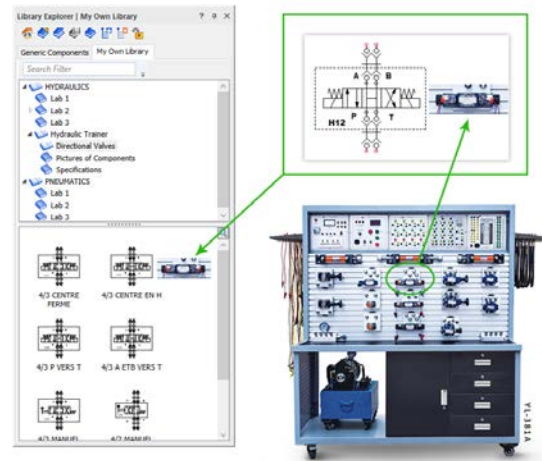

Change Properties to Simulate Different Scenarios

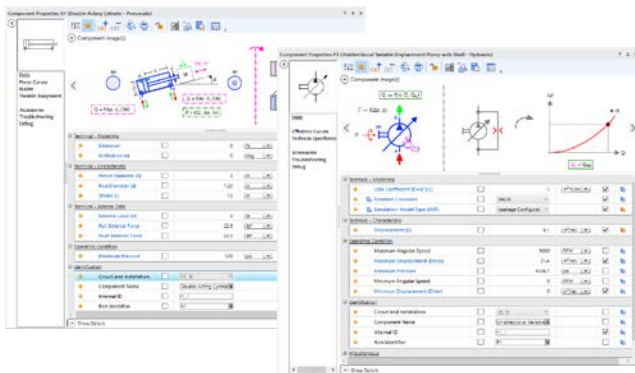

Activate Predefined Failures or Create Your Own to Improve Troubleshooting Skills

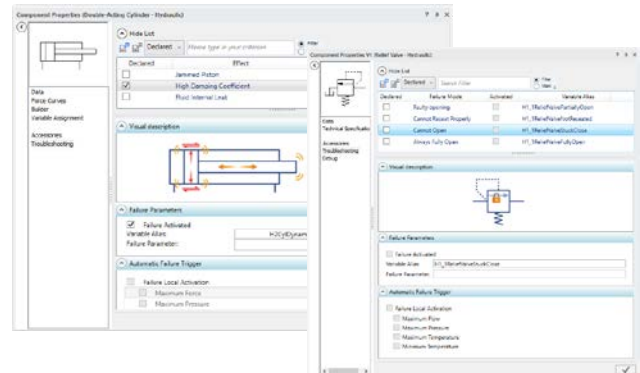

And More

- Easily drag and drop components on the schematics to create circuits
- Arrows and animated lines indicating flow direction
- Colors indicating different pressure, flow rate, or flow speed thresholds
- Measuring instruments such as pressure gage, flow meter, plotter and more
- Teachware and premade exercises
- Reproduce exercises you are currently using in your program
- Create custom libraries containing only the required components to specific exercises
- Copy and paste your circuits to other applications
- Hydraulics and pneumatics sizing sheets
- Export your schematics to PDF, DXF and more
- Print your circuit on any paper formats
- Improve blueprint reading skills by working directly with ISO symbols
- Automatic Bill of Materials generation
- Cut-away components to illustrate internal behaviour
- Pre-configured components that behave according to OEM's specifications in the Manufacturers' Catalogues

- Create ✓
- Simulate ✓
- Troubleshoot ✓

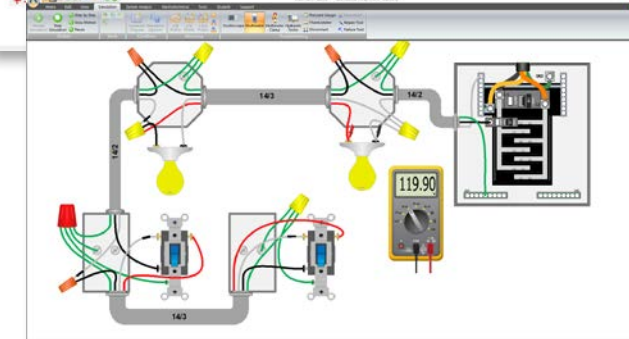
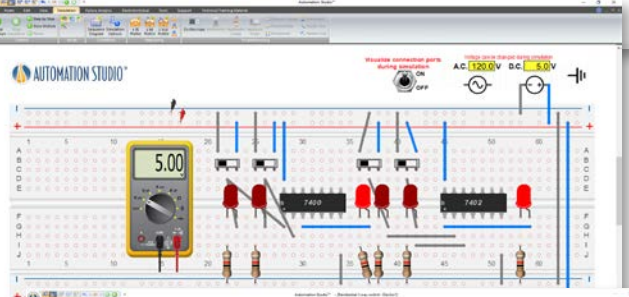
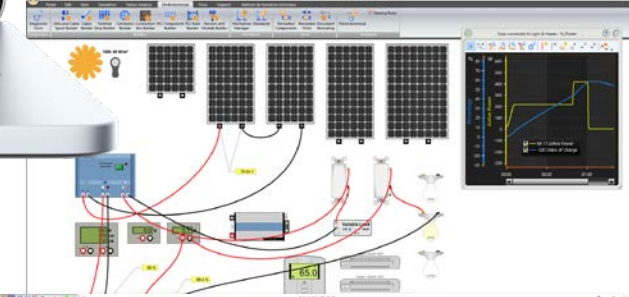
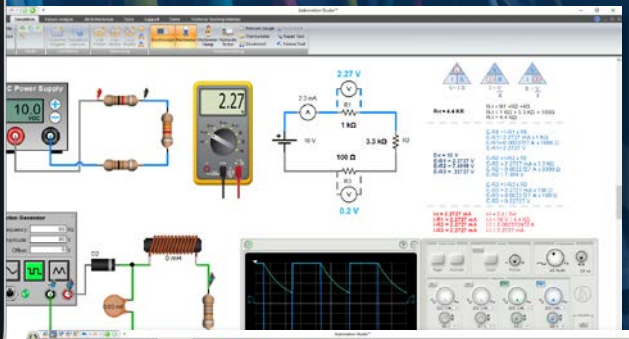
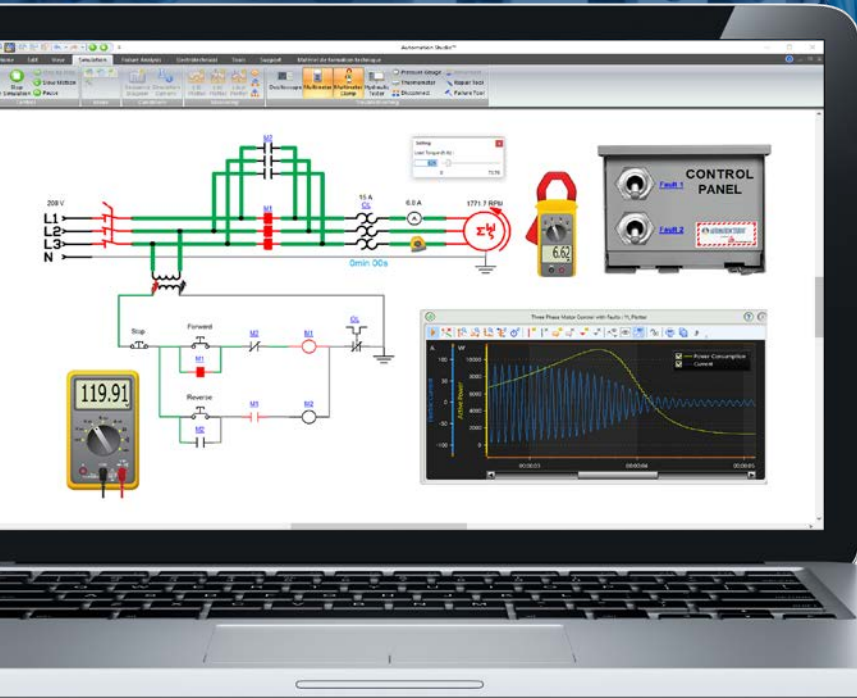

Whether You Are Teaching AC, DC, Motor Controls, Renewable Energy or Residential Electricity, We Have a Solution for You!

The electrical library allows to create, simulate and troubleshoot electrical circuits. It offers a wide array of symbols and illustrated components to create different electrical circuits, from basics to advanced. It supports IEC, NEMA, JIC and SAE standards. Realistic measuring instruments such as a multimeter, clamp meter and oscilloscope, can be used to reproduce real-life measuring and fault-finding experiences, enhancing students' troubleshooting skills.

Thousands of Symbols and Illustrated Components to Choose From

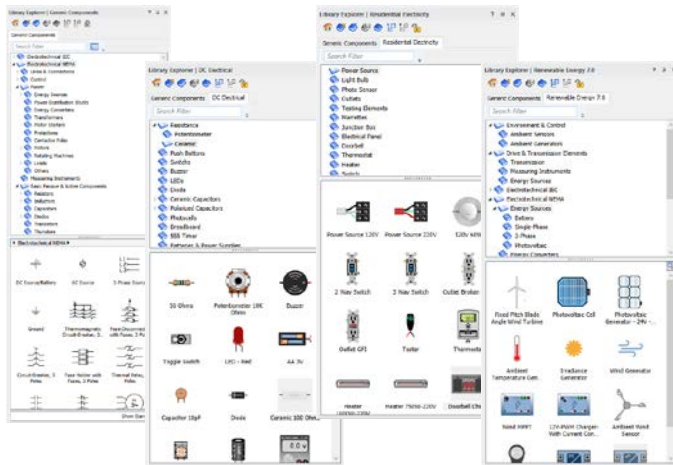

Create Wiring Diagram with Illustrated Libraries

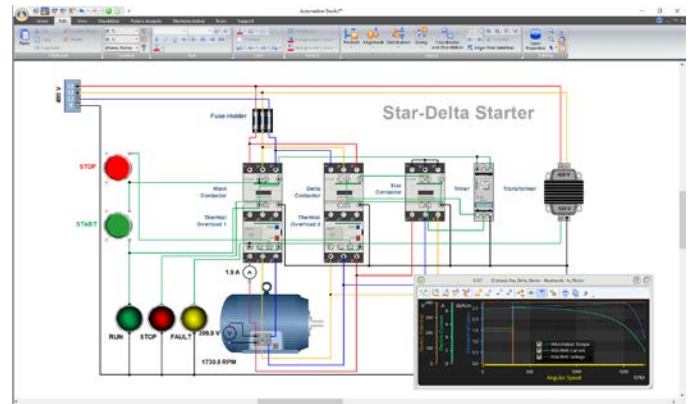

Properties Can Be Changed to Reproduce Lab Exercises

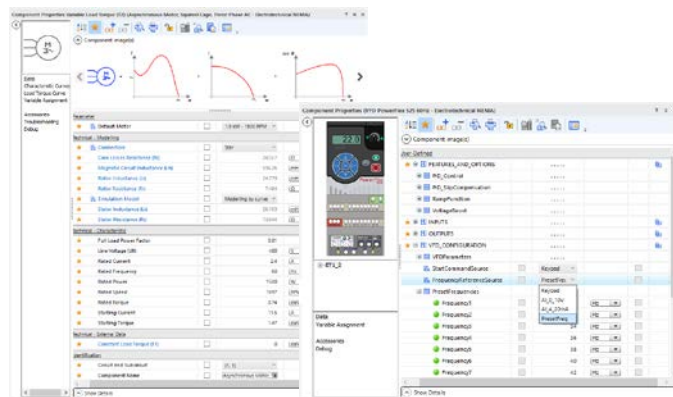

Activate Predefined Failures or Create Your Own

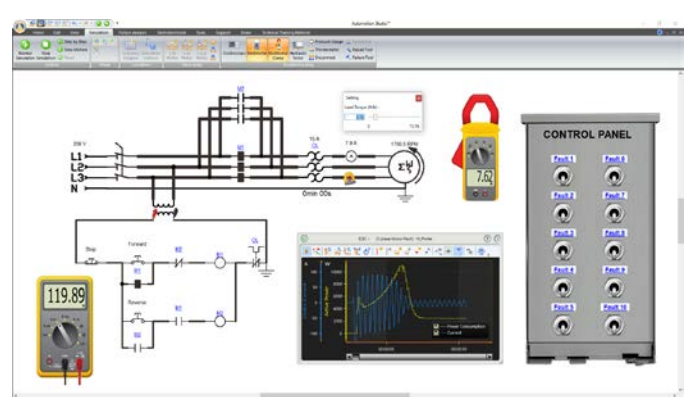

And More

- Drag and drop components on the schematics to create circuits with NEMA or IEC symbols
- A breadboard can be used to create DC circuits
- Simulation modes: normal, slow motion, step-by-step and paused
- Measure amp, volt, watt, frequency, power factor and more during simulation
- Teachware and premade exercises on basic circuits
- Copy and paste your circuit to any other application
- Variable frequency drives, electrical components, and more in our Manufacturer's Catalogues
- Electrical one-line diagram for power grid circuits
- Electrical sizing sheets
- Export your schematics to PDF, DXF, and more
- Improve blueprint reading skills by working directly with IEC and NEMA symbols
- Automatic Bill of Materials generation
- Simulation pace adjustable up to 1μs

- Create ✓
- Simulate ✓
- Troubleshoot ✓

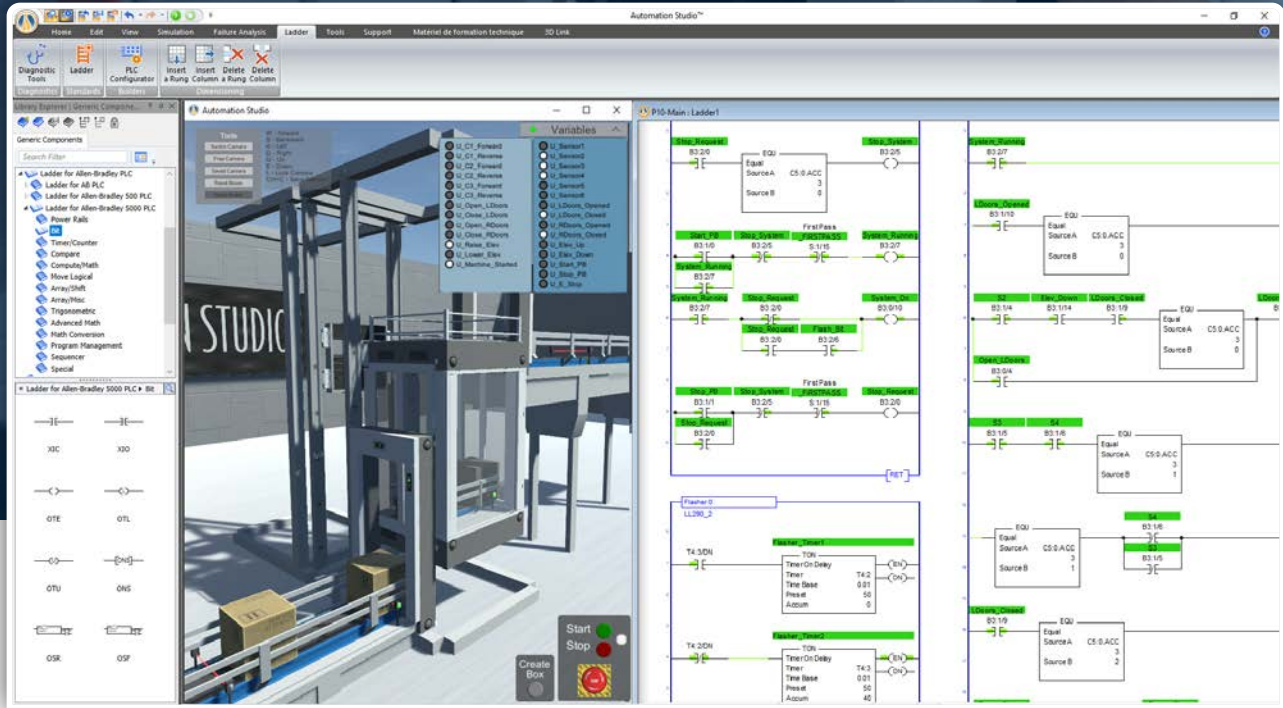

Write Your Ladder Logic Program to Control Other Technologies

The PLC Ladder Logic Libraries allow creating and troubleshooting of PLC circuits. They offer a wide array of components from Allen Bradley™ AB-500 and AB-5000, Siemens™, LS Electric™, Mitsubishi MELSEC iQ-R Series and IEC 61131-3. They can be used to control any circuit within Automation Studio™ using sensors, solenoids, lights, switches and more.

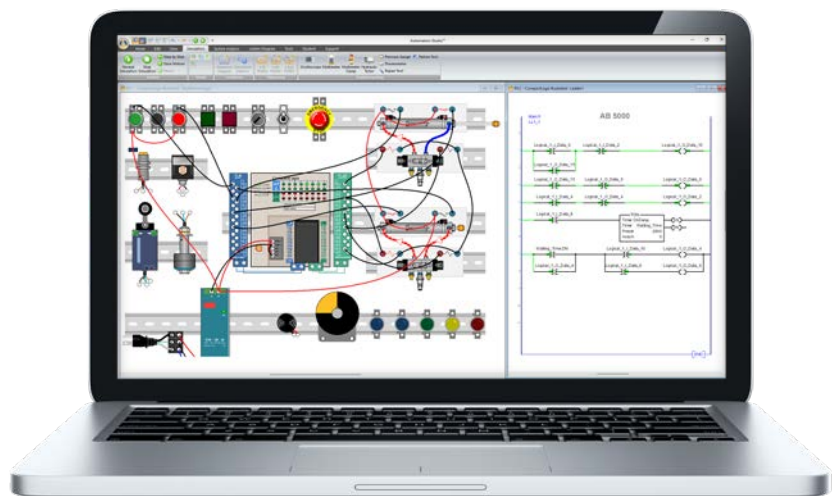

Components and Function Sets According to Manufacturer's Specifications

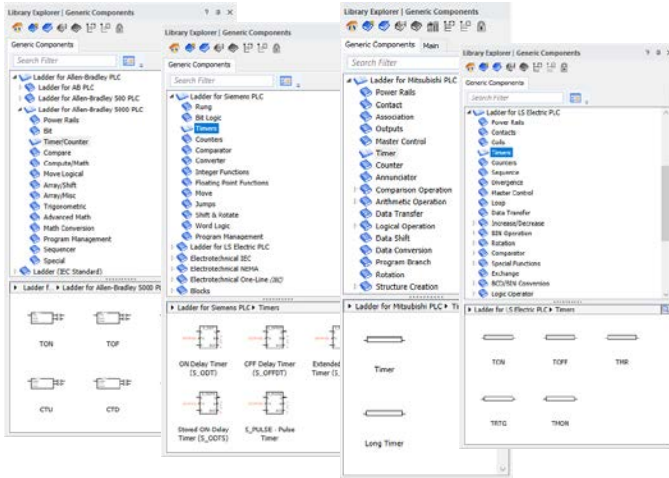

Cross Reference Inputs/Outputs

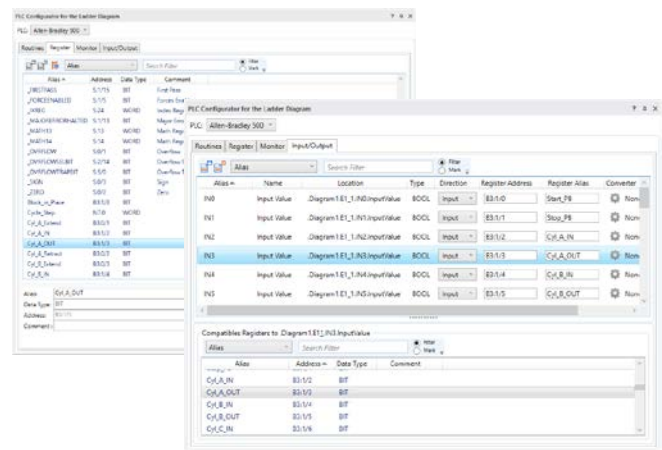

Syntax Help and Validation

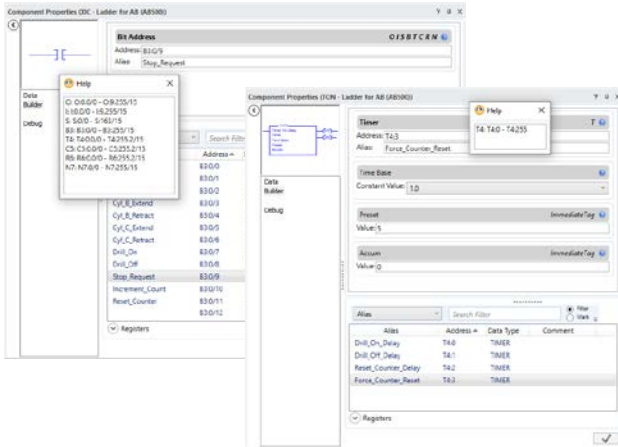

Learn How to Connect Real Looking PLCs

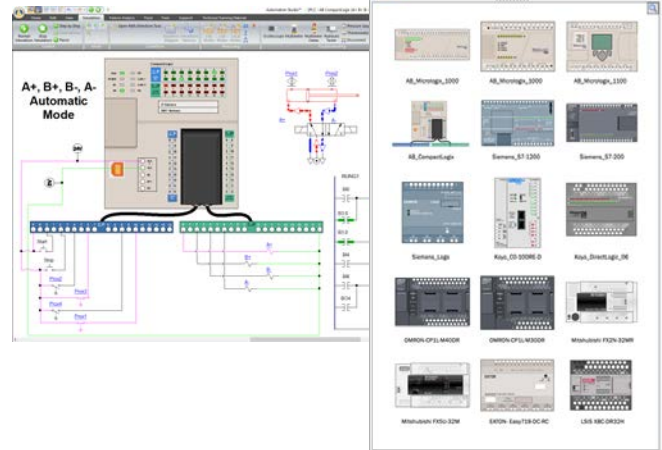

And More

- Control other technologies: hydraulics, pneumatics, electrical, etc.
- Monitor states during simulation
- Instructions set for Allen Bradley™ AB-500, AB-5000, Siemens S7, LS Electric™, Mitsubishi MELSEC iQ-R Series and IEC 61131-3
- Force instructions during simulation
- Insert additional rungs or columns between already made logic

Connect to Real Devices Such as PLCs and Controllers Through OPC

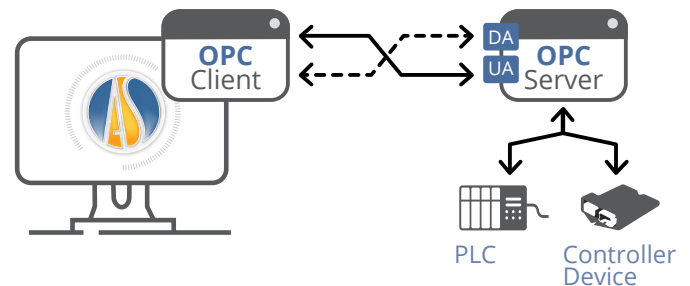

- Create ✓
- Simulate ✓
- Troubleshoot ✓

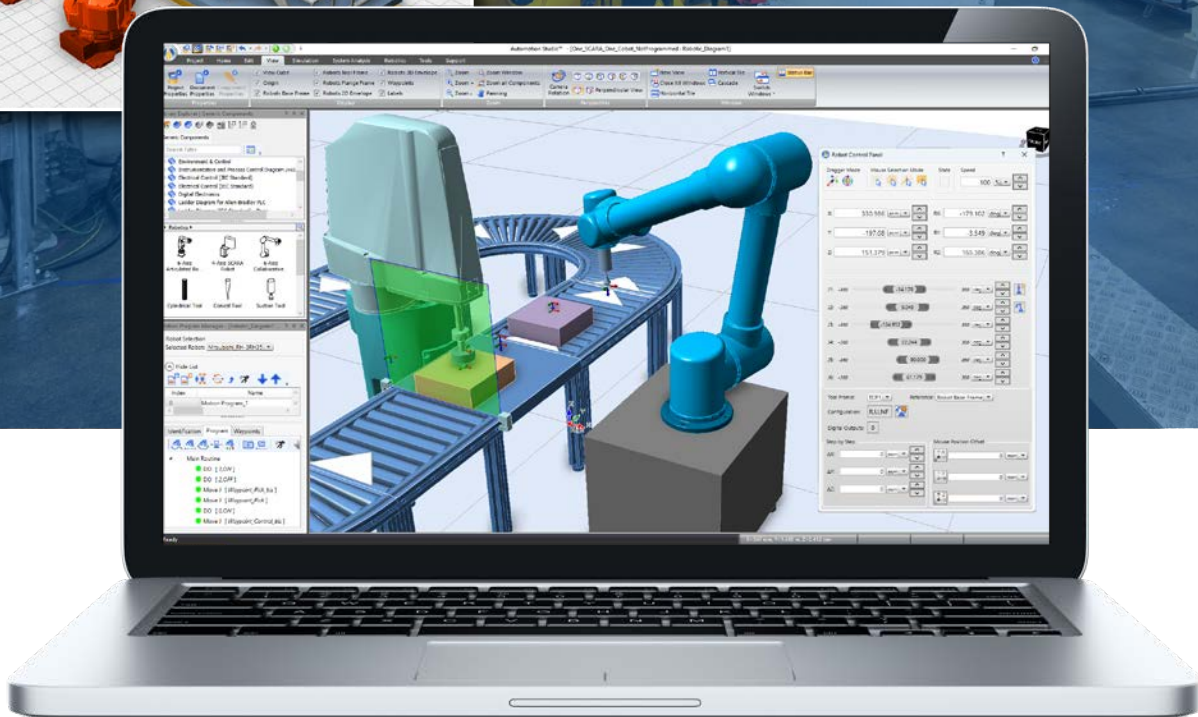

Design, Configure and Simulate Your Own 3D Robot Lines

The robotics workshop offers a suite of powerful tools to create and simulate sophisticated robotic workcells. Its cutting-edge robot simulator accurately replicates the dimensions and functionalities of various industrial robot systems, enabling users to intuitively operate these virtual robots within a dynamic 3D environment.

- Synchronize robots with conveyors for seamless operation and efficient load handling
- Real time analysis of the joint velocities to control the precision and to secure your equipment
- Experiment with different path-planning strategies, to ensure optimized motion
- Effortlessly position robots, conveyors, sensors or 3D objects within the workcell to build customized production lines
- Experience seamless manual operation with features like joggling joints

Motion Program Manager

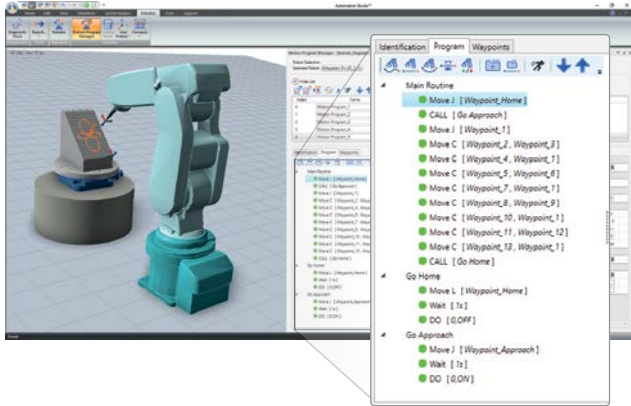

Workcell Visualization

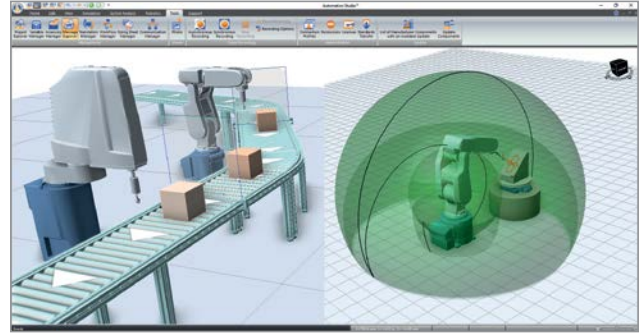

Workcell Design

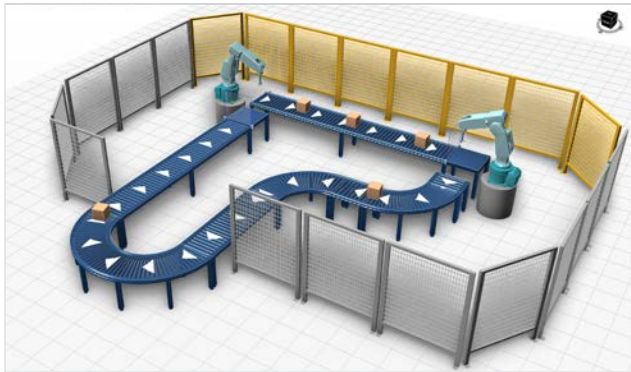

Robot Control Panel

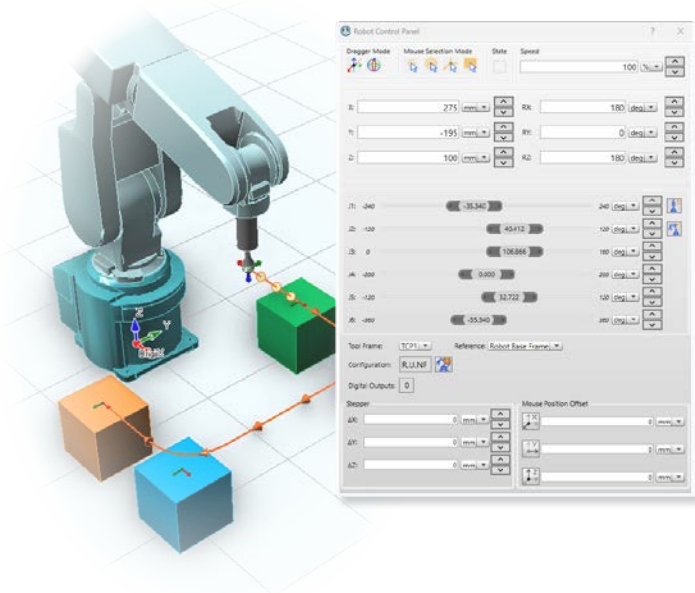

And More

- Create motion programs using a variety of instructions (such as move joints, move linear, move circle) tailored to most automation tasks
- Visualize the robot's path directly within the 3D scene or on a plotter using several validation tools
- Export the motion program to the native language of industrial robots
- Enjoy a user-friendly programming experience with no prior coding skills required, thanks to an intuitive tree structure and easy-to-use interfaces
- Include multiple robots in a workcell and operate them simultaneously, with interactions between robotic objects automatically handled by the simulator
- Enable robots to execute different motion programs based on commands from other devices or technologies
- Simulate robot motions in either kinematic or dynamic mode, tailored to your specific needs
- Leverage the Workshop's capability to create all-in-one simulations by integrating robots with other technologies within Automation Studio™

- Create ✓
- Simulate ✓
- Troubleshoot ✓

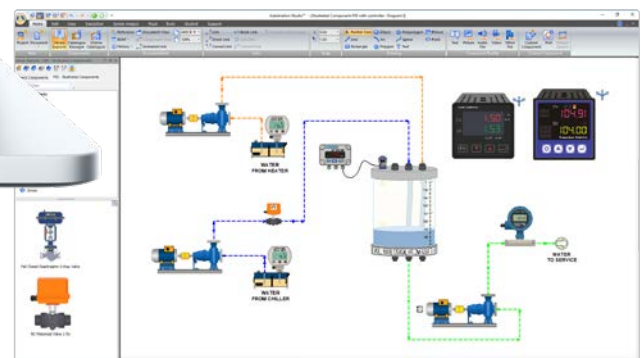
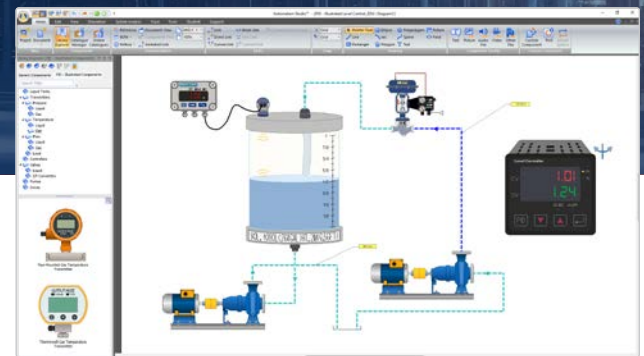
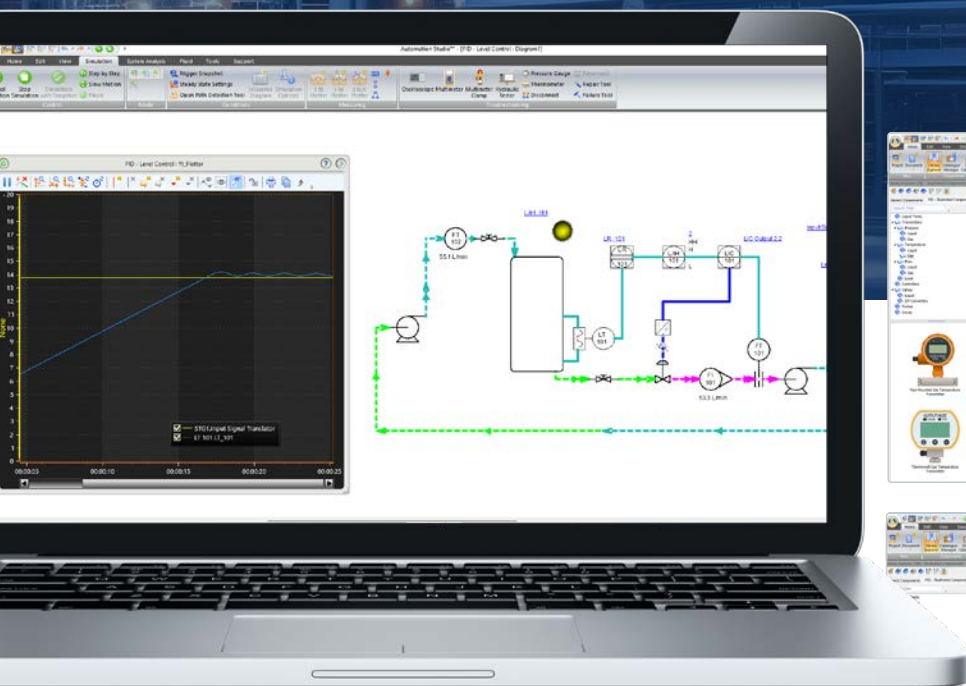

Adopt Automation Studio™ for Your Instrumentation & Process Control Projects!

Draw, simulate and analyze piping and instrumentation diagrams and process control system to equip students with the skills to understand, design, and interpret industrial processes.

Create Training Materials:

- Libraries of illustrated components frequently used in instrumentation and process control
- Preconfigured project templates for volume and temperature control training
- Create your own virtual training environment

ISA 5.1-2009 and ISO 14617 Symbol Libraries

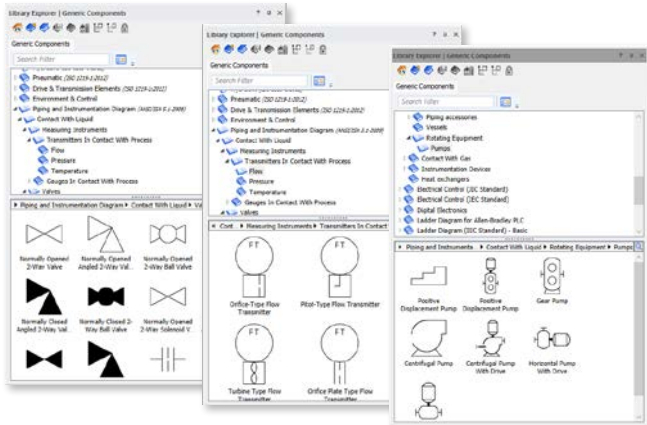

Component Models and Builders

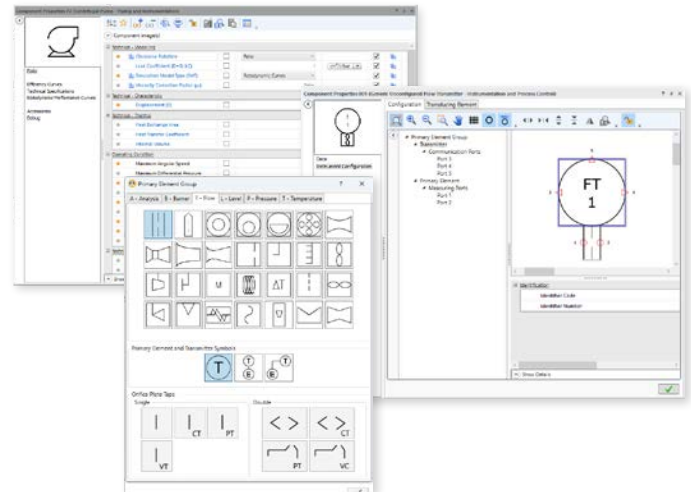

Modelling Lines and Fittings

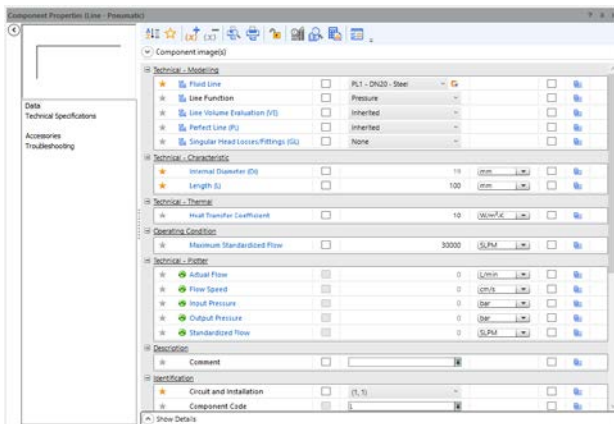

Steam and Gas Power Generation

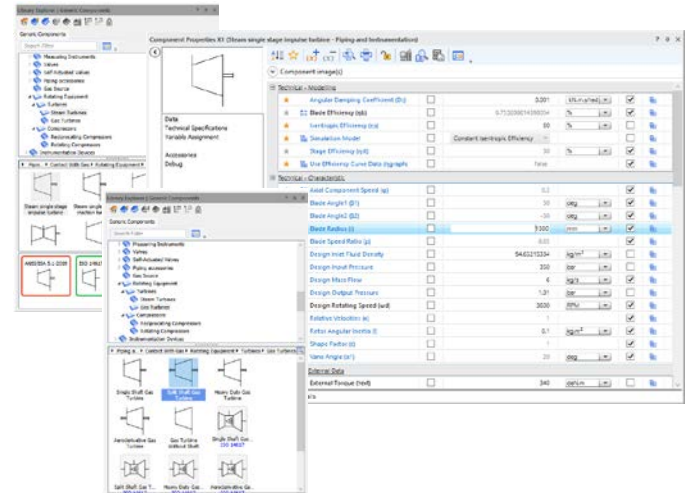

And More

- Easily design multi-technology circuits, including instrumentation representation
- Visualize key parameters during simulation, such as flow, temperature, density, pressure, torque, speed and power
- Effortlessly keep your circuit documentation up to date
- Perform optimization case studies by adjusting technical parameters and component performance during simulation
- Combine ISA components with other technologies, such as hydraulics, pneumatics, PLC, SFC, sequence diagram, controller and other Automation Studio™ modules
- Test key instrumentation and process control loops using simulation
- Use advanced analysis tools, such as plotters and dynamic measuring instruments

Sequential Control of Your System

Sequential Function Chart (SFC) / GRAFCET and Structured Text are methods of choice to design structured automation controls easily and efficiently. SFC is a graphical programming language among the languages identified by the IEC 61131-3 / IEC 60848 standards for PLC programming.

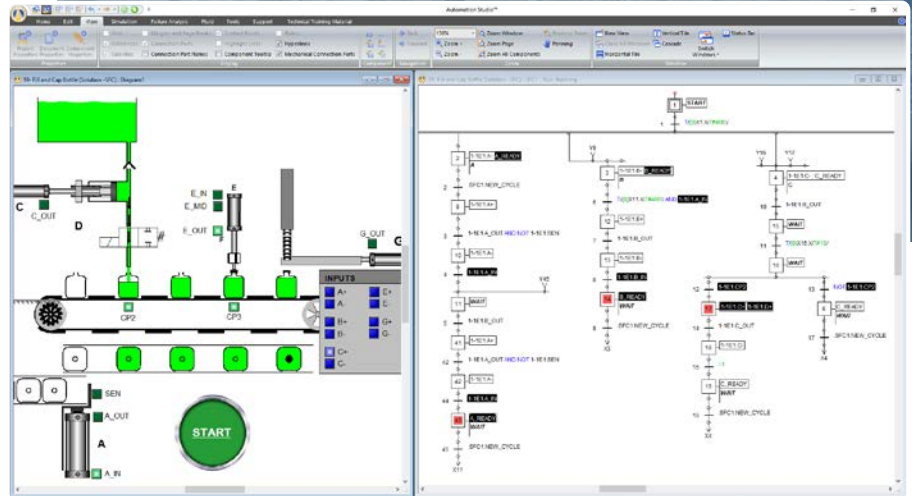

Dedicated Toolbar to Improve Design Time

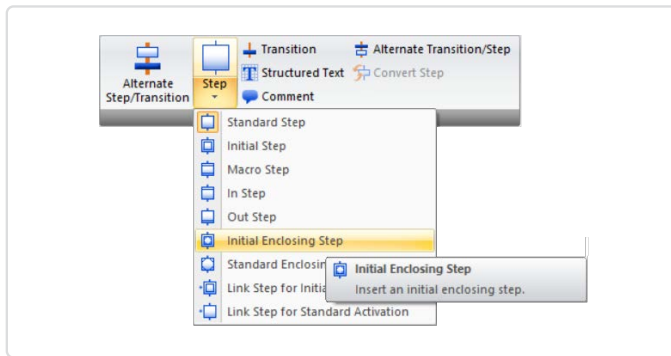

Structured Text

```

ST1
CYLINDER_B_EXT:=0 if E1_1.Start;
CYLINDER_A_EXT:=0 if E1_1.Start;

B_POS:= B_POS + B_SPD IF (( CYLINDER_B_EXT) AND (B_POS < 100));
B_POS:= B_POS - B_SPD IF ((CYLINDER_B_RET) AND (B_POS >= 0));

CYLINDER_B_IN:=1 IF B_POS <= 0;
CYLINDER_B_MID:=1 IF (( B_POS >= 40) AND B_POS <= 45);
CYLINDER_B_OUT:=1 IF B_POS >= 100;

CYLINDER_B_IN:=0 IF B_POS > 0;
CYLINDER_B_MID:=0 IF (( B_POS <40) OR B_POS >45);
CYLINDER_B_OUT:=0 IF B_POS < 100;

C_POS:= C_POS + C_SPD IF (( CYLINDER_C_EXT_R= 1) AND (C_POS < 100));
C_POS:= C_POS - C_SPD IF (( CYLINDER_C_RET_R= 1) AND (C_POS >= 0));
    
```

And More

- Interfacing with other technologies to control hydraulics, pneumatics or electrical circuits
- Hierarchical level management, branches and jumps
- Easily follow active steps or transitions
- Macro and enclosing steps
- Automatically insert AND and OR branches when needed
- Syntax checking during editing
- Simulation showing active steps and variable values
- Control of sequence and step activation time
- Forcing transition capability
- Macros and enclosures

2D and 3D Virtual Systems

- ✓ Create
- ✓ Simulate
- ✓ Troubleshoot

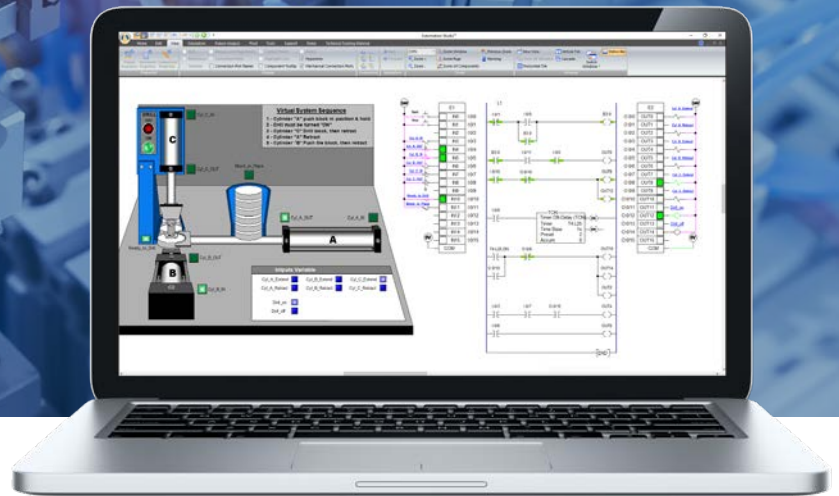

Control Real Systems

Using the Electrical and PLC Libraries as well as the SFC module, students simply link sensors, switches, lights, conveyors, etc., in order to control the pre-made Virtual Systems according to the teacher's instructions, such as traffic lights, garage doors, conveyors and more. 3D Virtual Systems are created using Unity 3D, allowing for a training experience with a high level of realism.

Garage Door



Conveyor Elevator



Painting Factory

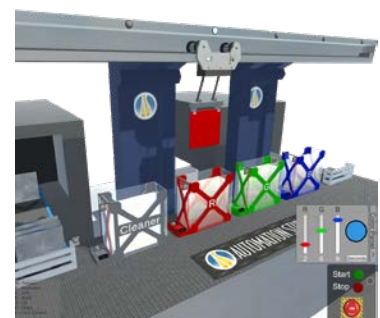

Pick and Place with Stamp

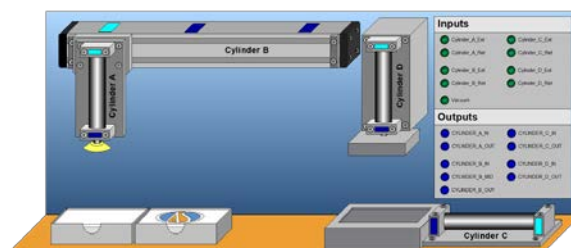

4-Way Intersection



Manufacturers' Catalogues

Automation Studio™ is the only software solution offering teachers and students an extensive library with thousands of preconfigured components that reproduce real world functions.

Save time with ready-to-use components from renowned manufacturers:

- Manage component options
- Create circuits with manufacturers' parameters
- Access instantly updated catalogue versions

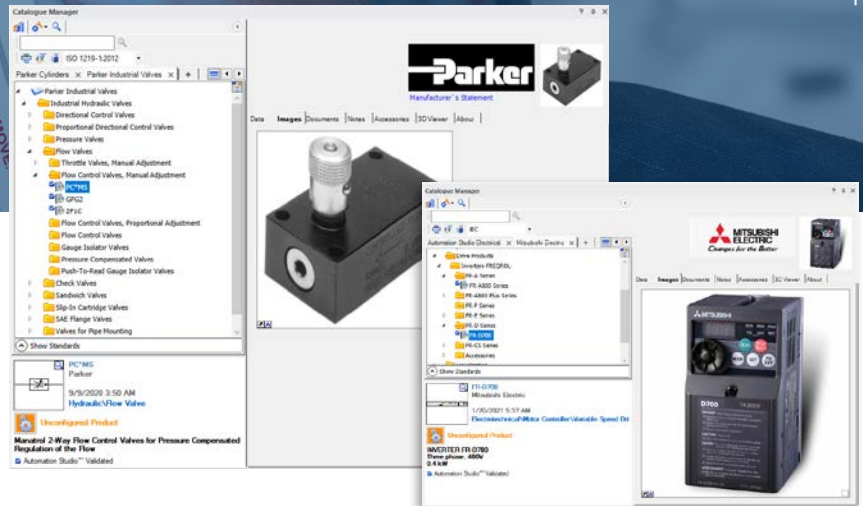

Each component has been carefully and rigorously bench-tested within Automation Studio™ to ensure that the simulation meets manufacturer's typical application and performance specifications. The virtual test benches are available for every component included in these catalogues.

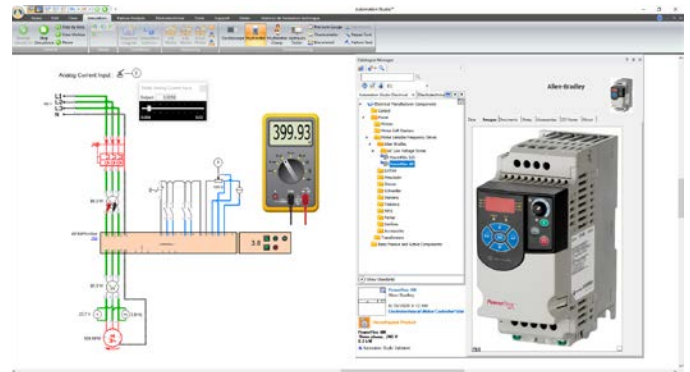

And More

- Catalogues for hydraulics, pneumatics and electrical
- Compare components behaviour
- Explain behaviour or more complex components easily with test benches
- Constantly updated with additional components from various manufacturers

Electrical Controls

- ✓ Create
- ✓ Simulate
- ✓ Troubleshoot

The Electrical Controls Library interacts with all components from other libraries to create relay logic controlled systems. It supports IEC and JIC standards.

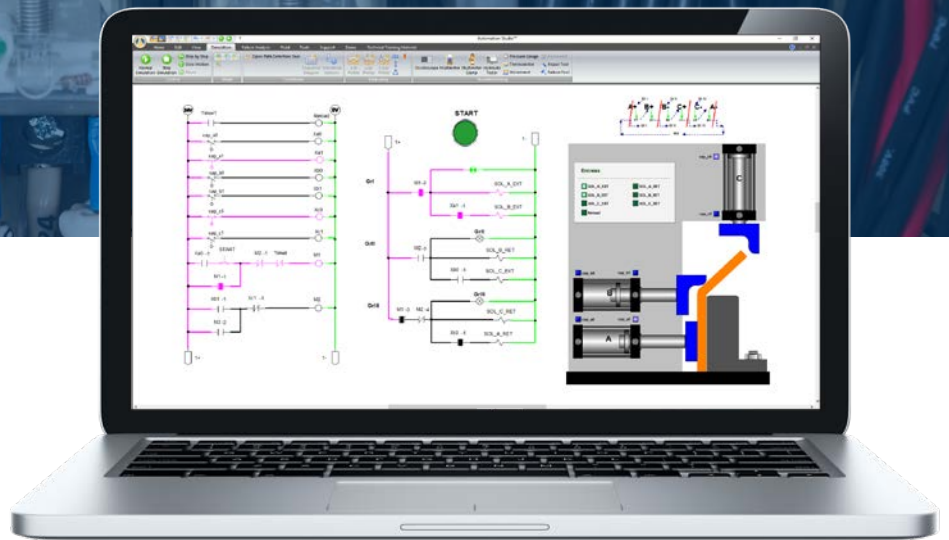

Digital Electronics

- ✓ Create
- ✓ Simulate
- ✓ Troubleshoot

The Digital Electronics Library comes complete with standard devices including inverters, logic gates, flip-flops, counters, shift registers, comparators, switches, LEDs, 7-bar displays, decoders, multiplexers, etc. Because of its output relay, you can also use this module to interact with other technologies.

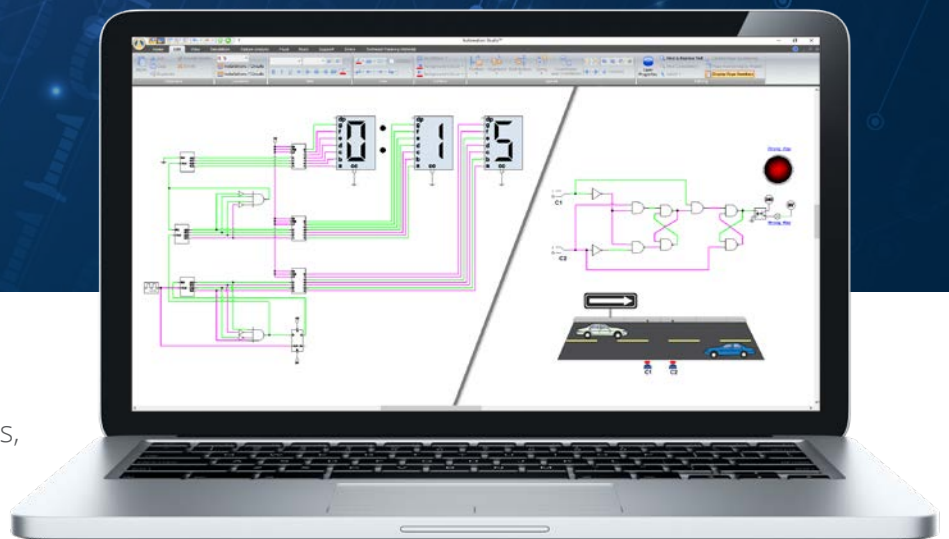

- ✓ Create
- ✓ Simulate
- ✓ Troubleshoot

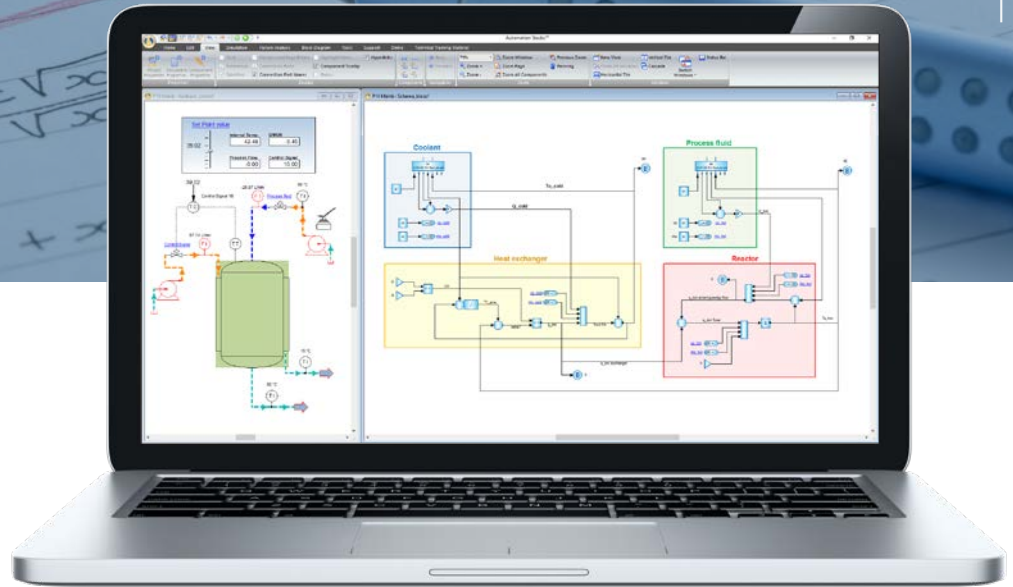

Create Your Own Mathematical Models

Users have the freedom to create their own mathematical models to represent the behaviour of custom components of any technology. This modelling capability will allow them to enrich models of all workshops. A more in-depth simulation can also be accomplished by modelling physical phenomena, such as air, resistance, friction, slippage, etc.

Control Algorithms

The Block Diagram Workshop allows to create and test control loops with multi-technology systems. As such, users can observe the effects of modifying algorithm parameters on the machine's characteristics. This helps better understand the system's behaviour for complex applications, improve performance and prevent issues before they occur.

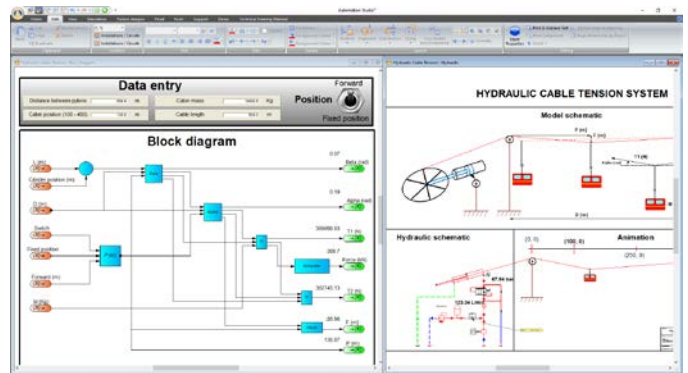

3D Multibody Dynamics

Build, Simulate, and Understand Mechanical Systems

Automation Studio™ enables students and instructors to build, visualize, and simulate mechanical systems in an intuitive 3D environment. By assembling components, applying loads, and observing forces, torques, and motion in real time, users can quickly understand how mechanisms behave and interact in practical and industrial applications.

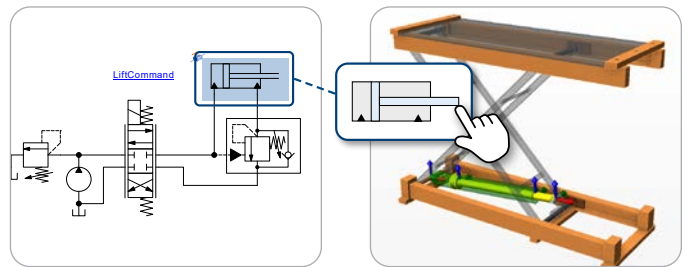
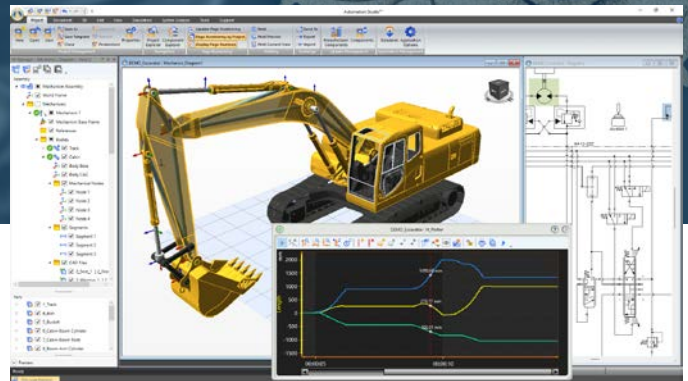

And More

- Effortlessly place and orient bodies, joints, gears, or external loads in 3D
- Switch between skeleton representation and real-world CAD models
- Extensive collection of joints and transmissions
- Easy integration of actuators such as hydraulic cylinder or motor shaft
- Advanced simulation capabilities for 3D multibody dynamics
- Wide range of state variables (positions, velocities, forces, torques) for analysis
- Seamless integration and co-simulation with hydraulics, electrical, pneumatics, math and PLC workshops

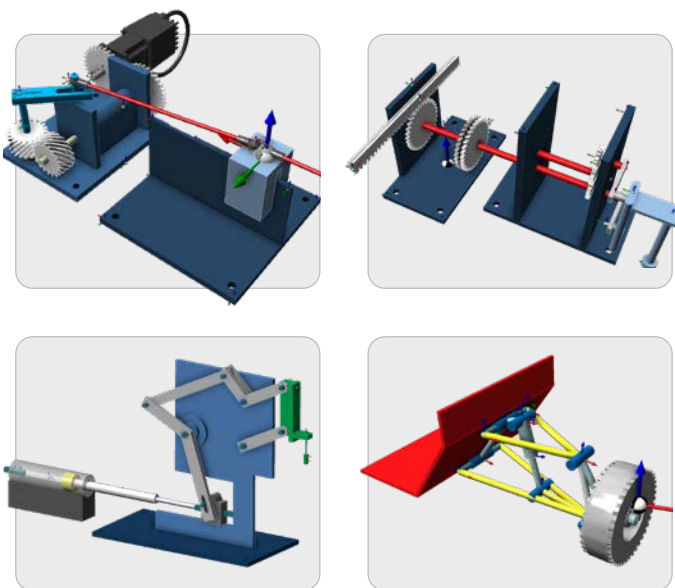

Teachware and Lab Exercises for an Interactive Experience for Students

Interactive lab exercises are available for different technologies to test students' comprehension. These exercises include simple schematics that can be simulated with questions to be answered. Automation Studio™ offers guides, lectures, animations and lab notes for all levels of discipline. Unlike other teachware made using multimedia sequences, course content offered by Automation Studio™ is interactive and animated live by the software's simulation. Instructors have the flexibility to modify these exercises or create their own.

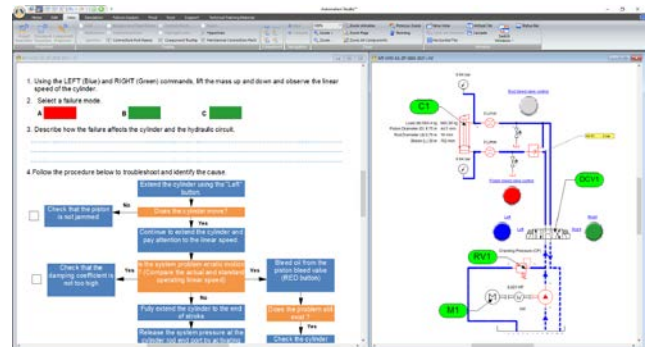
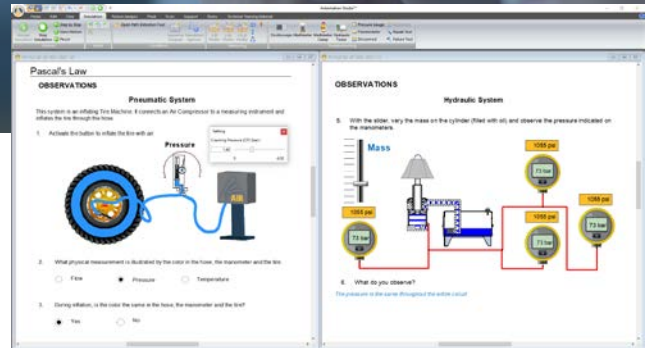

And More

- Users can insert pictures, text, external links to create interactive documents
- Parameters can be changed during simulation to compare different scenarios
- A workflow module can be added to automate functionalities
- Easily adaptable to any hardware equipment you already have
- Exercise can be saved, exported, printed or sent by email
- Record your screen and share with your students on any platform

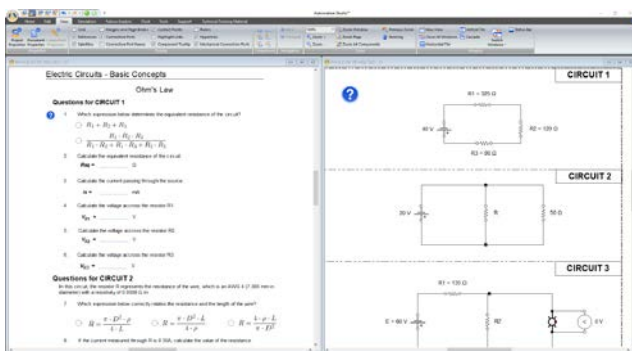

e-Learning

Remote Access

Easy-To-Use, Reliable and Accessible, Wherever You Are!

Remote access capabilities enable teachers and students to use the software from school and from home for e-Learning. They can now do homework and perform simulations wherever they are! Permissions can be edited to allow or deny access to features of the software to the students to test their skills.

Configurable License Manager

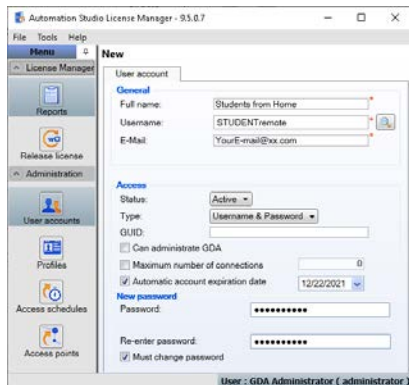

Screen Capture Your Content for Easy Sharing

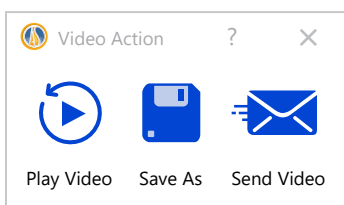

Digital Twins of Your Equipment to Be Used in Class or at Home

Complement your hardware equipment by allowing students to create the assignment virtually in Automation Studio™, prior to using your expensive lab equipment.

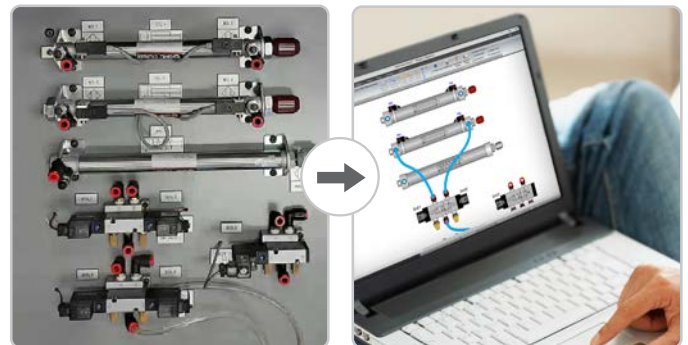

And More

- License Manager enables for accessibility, right and priority settings
- View in-use/available licenses, access schedules and license usage reports
- Share files through your favorite online application
- Record your simulation in a MP4 format and share it with your students

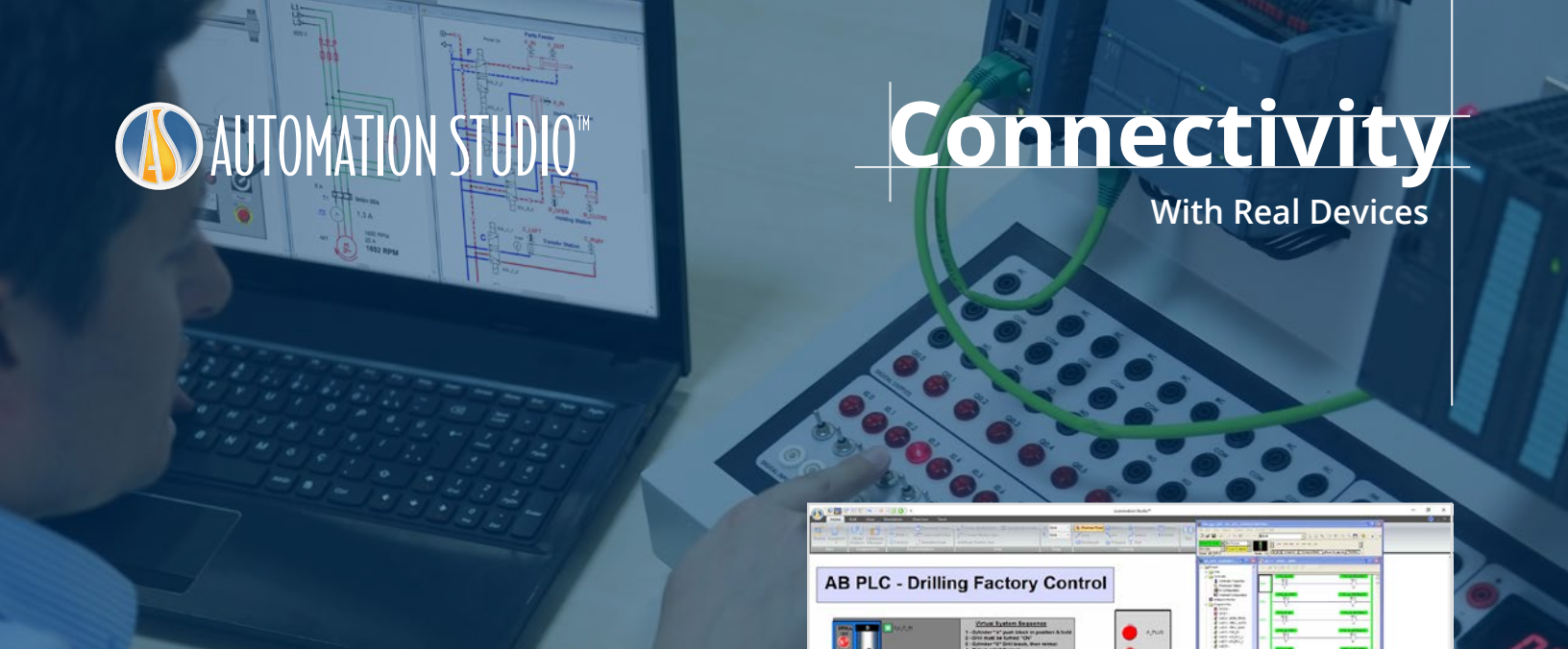

Exchange Inputs and Outputs with Real PLCs, Controllers or Any Devices That Are OPC Compatible

Being an OPC Client, Automation Studio™ can exchange inputs and outputs with real PLCs, Arduino, Raspberry Pi or any device that has an OPC Server.

Establish Connectivity with Communication Manager

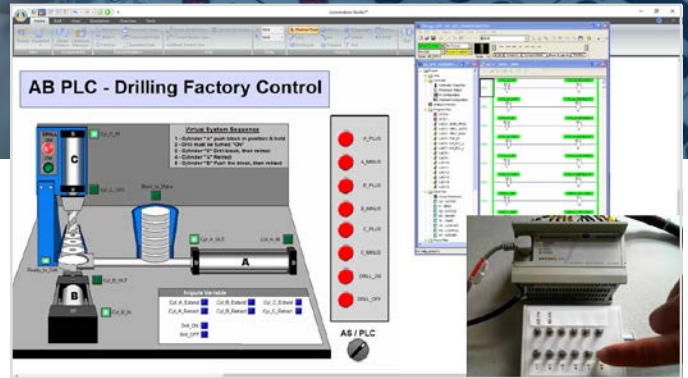
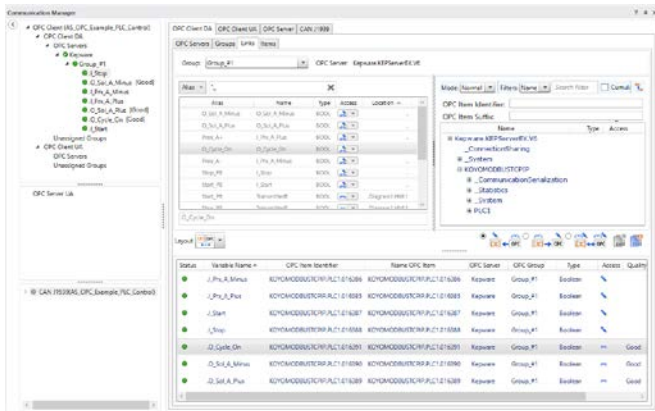

Easy To Use Linking Interface

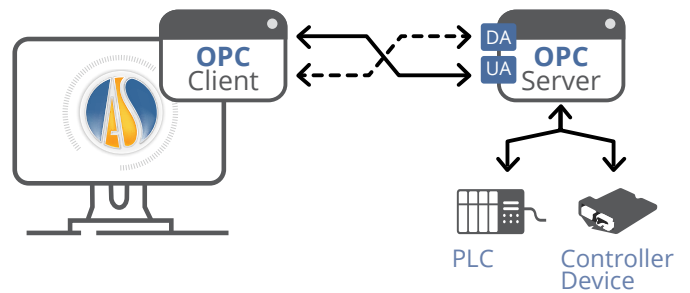

And More

- Control 2D and 3D Virtual Systems with your real PLC
- Test your PLC logic by controlling a circuit in Automation Studio™
- PLC illustrated libraries include a preconfigured connectivity with OPC Server
- Automatically detect installed OPC Server
- Linking interface between Automation Studio™ and hardware devices
- Communicate with IoT and IIoT
- Connect to Andon Studio™ Industry 4.0 software through OPC



Andon studio™

Industry 4.0

Integration with

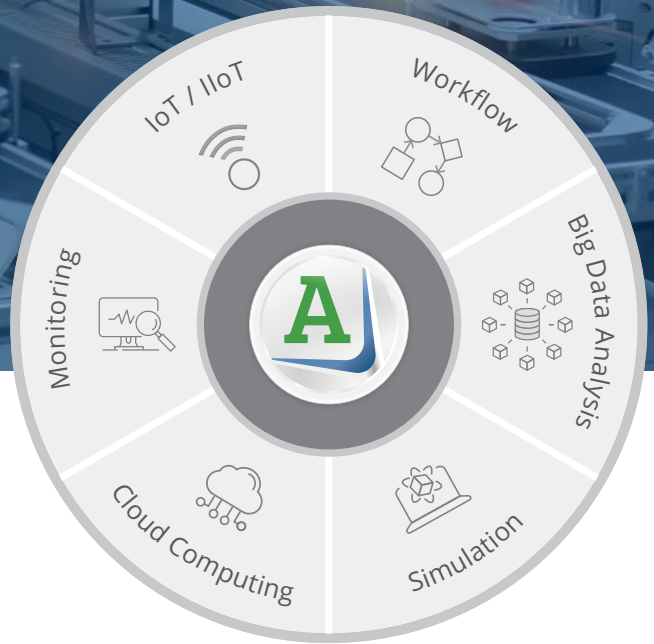

Industry 4.0 at Your Fingertips

Andon Studio™ lets you monitor productivity in real time, optimize operations and manage processes. Make the most of Industry 4.0 potential by acquiring, sharing and using data to improve productivity and strengthen continuous improvement initiatives. Flexible, easy to use, modular and configurable, Andon Studio™ is a unique training solution.

Introduce Your Students to Industry 4.0 Workflow Simply and Efficiently with Andon Studio™



Receive SMS Alarms in Real Time or Within the Andon Studio™ App

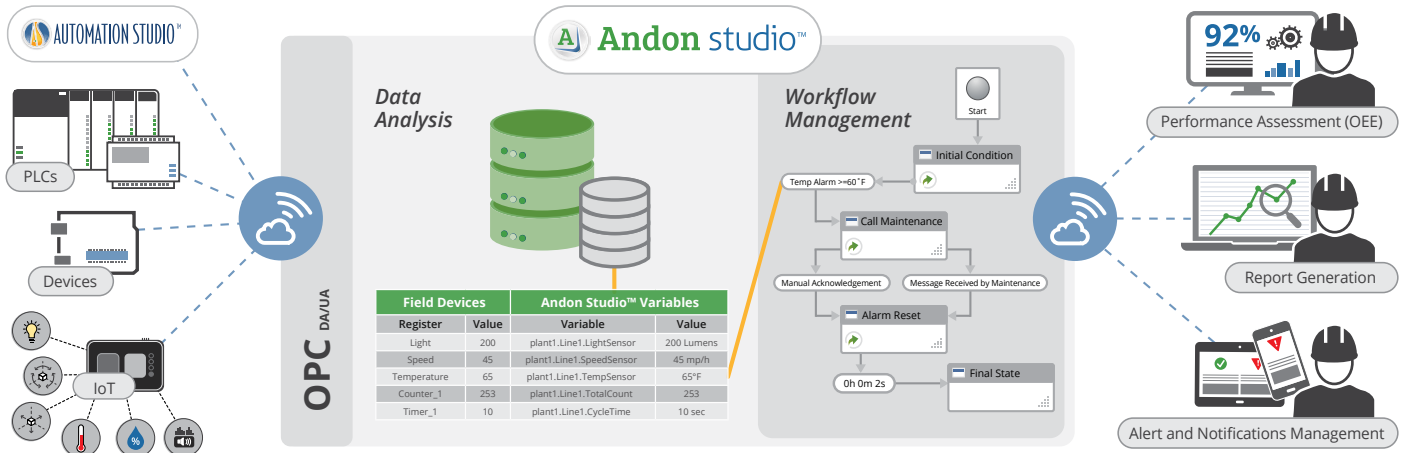

Libraries and Modules

- Electrical AC/DC, Motor Controls
- Hydraulics (ON/OFF and Proportional)
- Pneumatics (ON/OFF and Proportional)
- Electrical Controls
- PLC Ladder Logic, Allen Bradley™, Siemens™, Mitsubishi, LS Electric™, IEC 61131
- Robotics
- Instrumentation and Process Control
- Sequential Function Chart (SFC) / GRAFCET, Structured Text
- Digital Electronics
- Electrotechnical One-Line
- HMI and Control Panels
- 2D and 3D Virtual Systems
- Block Diagram-Math
- Fluid Power Component Sizing
- Electrical Component Sizing
- Troubleshooting and Diagnostics
- Mechanical Links
- 3D Multibody Dynamics
- CAN bus Connectivity
- Bill of Materials and Reports
- OPC Client, OPC Server
- SFC Export to Siemens and XML Format (Automation Studio™ PLC)
- API/Script Language
- Workflow Manager

Annual Maintenance and Technical Support Plan

Subscribe to our Annual Maintenance and Technical Support Plan, which grants you exclusive benefits, such as:

- ✓ Remote Access Licensing
- ✓ Software updates, service releases, new versions
- ✓ Online training session (2 hours)
- ✓ Unlimited access to technical support (phone, email, technical support portal)
- ✓ Teachware for hydraulics, pneumatics, electrical
- ✓ Manufacturers' Catalogues
- ✓ Access to already made 3D virtual systems

Free Online Demonstration

See Automation Studio™ and Andon Studio™ in action

www.famictech.com/Online-Demo



Famic Technologies Inc.

www.famictech.com/Edu

Distributed by

Canada (Headquarters)

Famic Technologies Inc.
300-8585, route Transcanadienne
Saint-Laurent QC H4S 1Z6
Canada

☎ +1 (514) 748-8050
☎ +1 (514) 748-8521



Germany

Famic Technologies GmbH
Julius-Hatry-Straße 1
68163 Mannheim,
Germany

☎ +49 (0) 621 15028 579

India

Famic Technologies Pvt. Ltd.
Tower S4, Unit No. 204, Magarpatta
Hadapsar, Pune, Maharashtra 411028
India

☎ +91 70 2822 1468