

TRAINING SYSTEMS

HYDRAULICS NG06

HRE
Automation

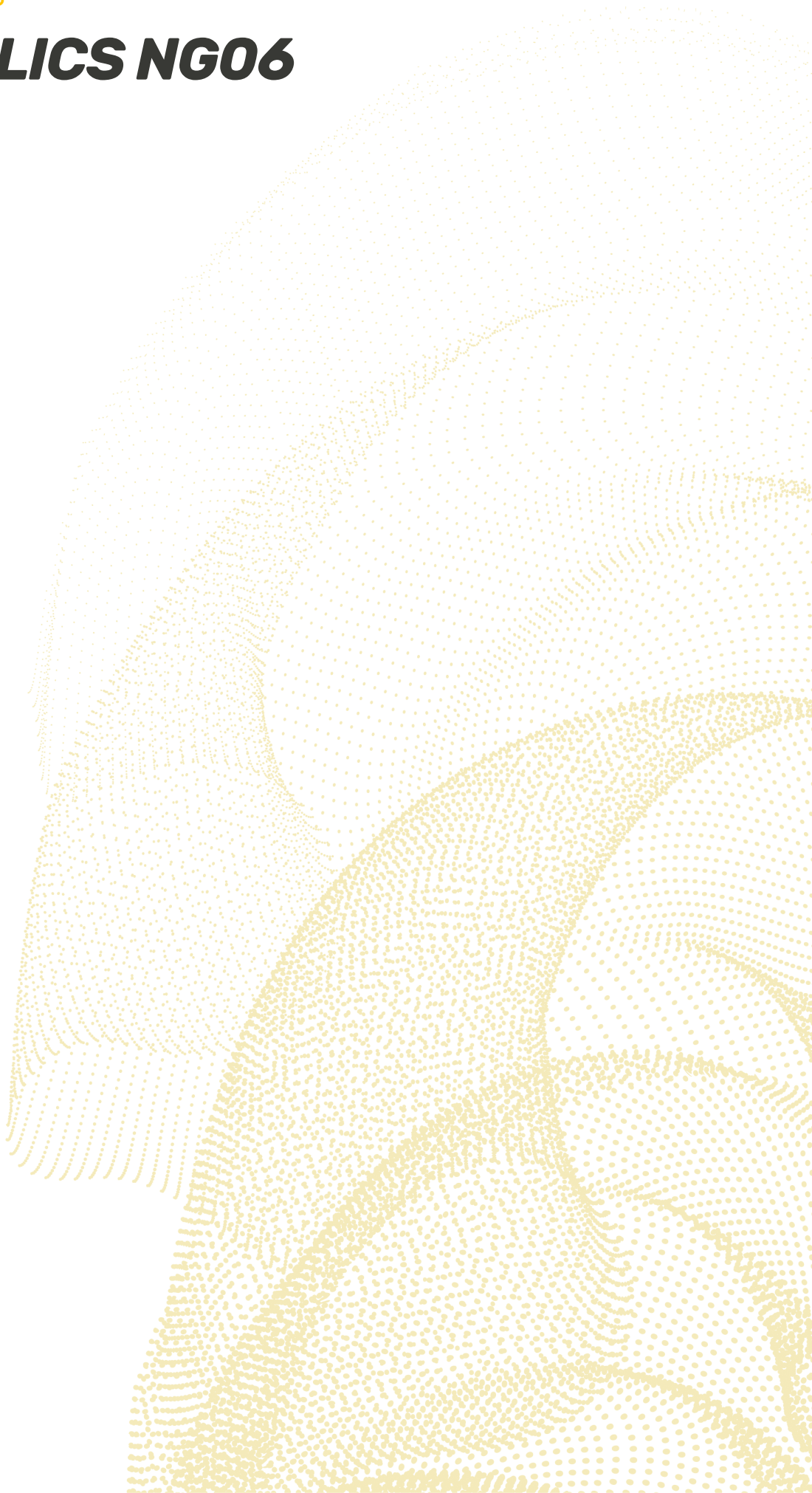

HRE Automation takes advantage of its industrial experience of more than 40 years in industrial automation and fluids, using it as a technological base to create equipment and educational systems that are perfectly suited to the demands of today's industrial market.

In the continuous search for excellence in teaching equipment, we are a company specialized in providing means for optimal training in the field of automation.

Offers:

- PRACTICE EQUIPMENT
- PEDAGOGICAL SUPPORT (TEACH WARE)
- PERSONALIZED ATTENTION

The teacher will be able to impart with ease and clarity, a quality theoretical-practical teaching. At the same time, it contributes to rapid learning by students, using equipment that will later be used in the work environment.

HRE
Automation

HRE Automation

C/ Ibaizarte 21

E-20870 Elgoibar (Gipuzkoa)

Spain



+34 943 742 130



+34 943 742 708



hre@hre.es



<http://www.hre.es>



HYDRAULICS – INDUSTRIAL NG06 SYSTEMS

Hydraulic training trolley HLA80.....	1
Hydraulic training trolley HLA70.....	3
Hydraulics level 1.....	5
Hydraulics level 2.....	9
Hydraulics complementary.....	11
Electro hydraulics level 1.....	17
Electro hydraulics level 2 – Modular Blocks 1-4.....	20
Electro hydraulics – Other Modular Blocks 5- 8.....	21
Electro hydraulics complementary	23
Proportional hydraulics level 1	27
Proportional hydraulics level 2.....	29
Proportional hydraulic accessories / complements.....	32
Proportional hydraulics level 3.....	34
Proportional hydraulics level 4.....	36

Hydraulic Training Trolley HLA80

HLA80-1/HLA80-2

Especially designed to training in hydraulics, electro and proportional hydraulics, featuring:

- Dimensions: 1594 x 850, 1936 mm (high).
- Metal structure painted in dark grey color, with 4 wheels, 2 of them are lockable.
- Metal working panel of 1350x1050 mm. With Ø17mm holes every 50mm (horizontally and vertically) for clamping hydraulic components without using any additional tool. Metal panel with Epoxi plastic paint covering, RAL 7035, to guarantee a long useful life in perfect condition. Upper frame for mounting electrical elements and other elements. **(Available with one panel HLA80-1 or with two panels HLA80-2)**
- Big fixed metal tray with plate grid under the panels to collect any eventual leak of oil. Directly connected to the oil deposit of the hydraulic power unit.
- Transparent device with graduated scale and anti-overflow system for volumetric measurements, one by working side
- 2 Pressure connections and 4 return connections at each working side
- Hydraulic power unit with fixed flow pump 5 l/min **(HLA80-2 with double pump and HLA80-1 with single pump)**. 1.2KW single-phase motor with capacitor start and start/stop button. With 30 liter tank mounted on the bottom of the bench structure with anti-vibration.
- Emergency button at each working side, to cut down electrical and hydraulic power supply.
- 3 sockets 220 Vac (or 110 Vac) at each side. 2P+T, 16 Amp.
- Just one single-phase plug for the hydraulic power unit and the electrical sockets
- **Drawers cabinet/Storage pyramid (optionals)**. Drawers or pyramid for each working position, for storing components. Cabinet with three drawers, central locking with key and safety protection (a single drawer can be opened at the same time). Each drawer has a metal tray to fix the elements. Metal pyramid similar to the panel
- 30 liters oil, HLP 32, and maintenance manual are included



HLA80-2 with 2 cabinet of drawers



HLA80-1 with 1 cabinet of drawers and 1 pyramid

HYDRAULIC POWER UNIT:

- Assembled onto the metal structure, under the panels, incorporate shake absorbers to avoid noise.
- Internal gear pumps. 5 liters /min (HLA80-1 one pump and HLA80-2 two pumps)
- Noise level 60 db - 1 meter
- Oil reservoir of 30 liters, with oil level viewfinder, air inlet filter and oil return filter
- Pressure relief valve with pressure gauge by pump, independent pressure regulation, The HLA80-2 trolley has a tandem motor with 2 pumps, the HLA80-1 trolley has a tandem motor with 1 pump.
- Single –phase electric motor 220 V 50Hz (optionally 110 Vca 50 – 60 Hz or triphasic), 1.2 Kw
- On-Off control box with two push buttons and motor overload protection.
- An emergency push button and a battery of 3 electrical outlets 230 VAC (or 110 VAC). 16 Amp, accessible at each workstation
- A distributor block with 2P and 4T hydraulic connections for each workstation. Self-sealing couplers and shut off ball valve

Every valve size will be NG06 – Cetop 3.

DIMENSIONS

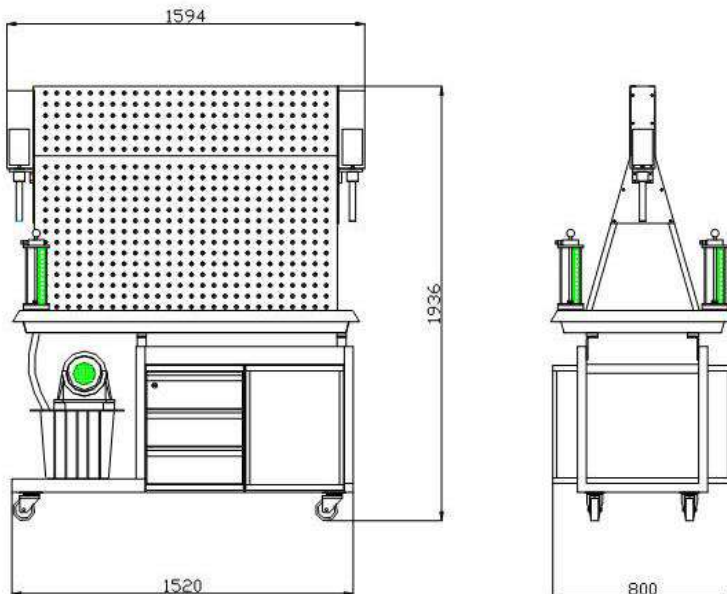

Single trolley HLA80-1

Mobile structure with one working panel and hydraulic unit with one fixed flow pump 5l/min

Ref. 53952010

Double trolley HLA80-2

Mobile structure with two working panels and hydraulic unit with two fixed flow pumps 2x5l/min

Ref. 53952011

Drawers´ cabinet for trolleys HLA80/70

3 drawers with fixing trays and safety protection with central locking

Ref. 13026977

Storage pyramid for trolleys HLA80/70

Two-sided, metallic with epoxy plastic paint and 17 mm diameter holes

Ref. 53952014

The trolley´s reference does not include the drawers / pyramid, ask with the order

Hydraulic Training Trolley HLA70

HLA70-1/HLA70-2

Especially designed to training in hydraulics, electro and proportional hydraulics, featuring:

- Dimensions: 1176 x 860, 1948 mm (high).
- Metal structure painted in dark grey color, with 4 wheels, 2 of them are lockable.
- Metal working panel of 950x1050 mm. With Ø17mm holes every 50mm (horizontally and vertically) for clamping hydraulic components without using any additional tool. Metal panel with Epoxi plastic paint covering, RAL 7035, to guarantee a long useful life in perfect condition. Upper frame for mounting electrical elements and other elements. **(Available with one panel HLA70-1 or with two panels HLA70-2)**
- Big fixed metal tray with plate grid under the panels to collect any eventual leak of oil. Directly connected to the oil deposit of the hydraulic power unit.
- Transparent device with graduated scale and anti-overflow system for volumetric measurements, one by working side
- 2 Pressure connections and 4 return connections at each working side
- Hydraulic power unit with fixed flow pump 5 l/min **(HLA70-2 with double pump and HLA70-1 with single pump)**. 1.2KW single-phase motor with capacitor start and start/stop button. With 30 liter tank mounted on the bottom of the bench structure with anti-vibration.
- Emergency button at each working side, to cut down electrical and hydraulic power supply.
- On-Off control box with two push buttons and motor overload protection. Just one single-phase plug for the hydraulic power unit
- **Drawers' cabinet/Storage pyramid (optionals)**. Drawers or pyramid for each working position, for storing components. Cabinet with three drawers, central locking with key and safety protection (a single drawer can be opened at the same time). Each drawer has a metal tray to fix the elements. Metal pyramid similar to the panel
- 30 liters oil, HLP 32, and maintenance manual are included



HLA70-1 with 1 cabinet of drawers

HYDRAULIC POWER UNIT:

- Assembled onto the metal structure, under the panels, incorporate shake absorbers to avoid noise.
 - Internal gear pumps. 5 liters /min (HLA70-1 one pump and HLA70-2 two pumps)
 - Noise level 60 db - 1 meter
 - Oil reservoir of 30 liters, with oil level viewfinder, air inlet filter and oil return filter
 - Pressure relief valve with pressure gauge by pump, independent pressure regulation, The HL70-2 trolley has a tandem motor with 2 pumps, the HLA70-1 trolley has a tandem motor with 1 pump.
 - Single –phase electric motor 220 V 50Hz (optionally 110 Vca 50 – 60 Hz or triphasic), 1.2 Kw
 - On-Off control box with two push buttons and motor overload protection.
 - An emergency push button, accessible at each workstation
 - A distributor block with 1P and 2T hydraulic connections for each workstation. Self-sealing couplers and shut off ball valve
- Every valve size will be NG06 – Cetop 3.

DIMENSIONS:

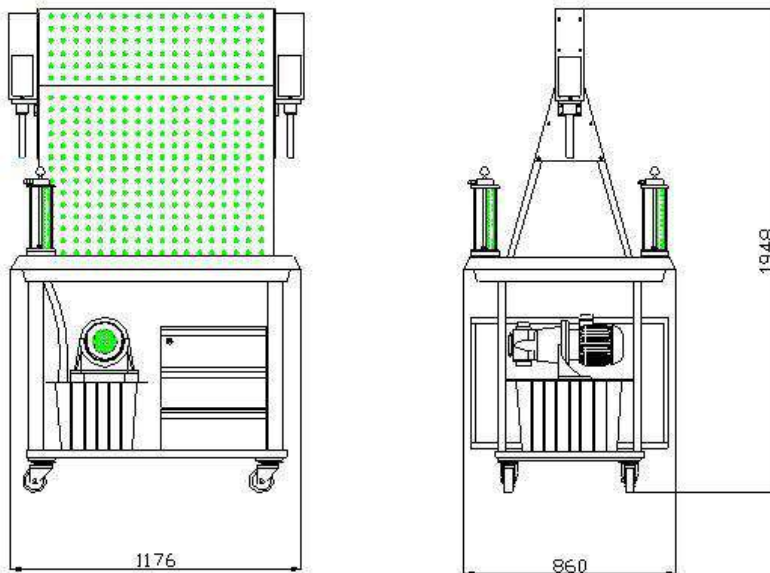

Single trolley HLA70-1

Mobile structure with one working panel and hydraulic unit with one fixed flow pump 5l/min

Ref. 53952012

Double trolley HLA70-2

Mobile structure with two working panels and hydraulic unit with two fixed flow pumps 2x5l/min

Ref. 53952013

Drawers' cabinet for trolleys HLA80/70

3 drawers with fixing trays and safety protection with central locking

Ref. 13026977

Storage pyramid for trolleys HLA80/70

Two-sided, metallic with epoxy plastic paint and 17 mm diameter holes

Ref. 53952014

The trolley's reference does not include the drawers / pyramid, ask with the order

Hydraulics level 1

Ref. 53952015

1



Double acting differential cylinder

Ø32 / Ø22, 200 mm stroke.
Over plate with cam and quick fit connectors
Ref. 13025799 Units.1

2



Set of 12 hoses with quick female connectors

8 hoses NW6 x 500 mm length
4 hoses NW6 x 1000 mm length
Ref. 13025794 Units.1

3



Cross distributor

4 connection, with quick fit connectors
Ref. 13026559 Units.1

4



2 "T" distributor with pressure gauge 0...60 bar

Glycerin damped, with quick fit connectors
Ref. 13025792 Units.2

5



Shut off ball valve

With graduated scale and quick fit connectors
Ref. 13025806 Units.1

6

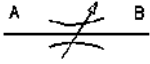

Two way flow restrictor
with quick fit connectors
Ref 13025803 **Units.1**

7

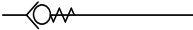

One way restrictor
Non-return valve over hose
Ref. 13025805 **Units.1**

8

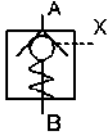

Piloted one way restrictor
Cartridge valve inserted in a
block with quick fit
connectors
Ref. 13025813 **Units.1**

9



One way flow restrictor
With quick fit connectors
Ref. 13025804 **Units.1**

10

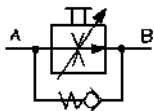

**Pressure compensated one
way flow regulator**
NG06 valve onto base plate
with quick fit connectors
Ref. 16100015 **Units.1**

11

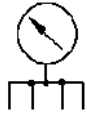

4 connections distributor on manifold with pressure gauge 0...60 bar

Glycerin damped, on base plate with quick fit connectors
Ref. 13025741 **Units.1**

12

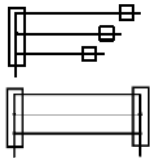

Set of tubes for testing pressure drops One item with 3 different diameters and the same length, another item with 3 different lengths and the same diameter
Ref. 13025791 **Units.1**

13

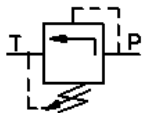

2 pressure relief valve 2...64 bar
Cartridge valve inserted in a block with quick fit connectors
Ref. 13025811 **Units.2**

14

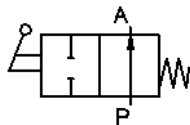

2/2 manual acting valve, spring return

NG06 valve onto base plate with quick fit connectors
Ref. 16100016 **Units.1**

15

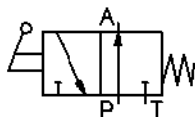

3/2 manual acting valve, spring return

NG06 valve onto base plate with quick fit connectors
Ref. 16100017 **Units.1**

16

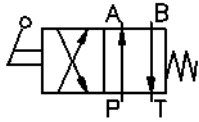

**4/2 manual acting valve,
spring return**

NG06 valve onto base plate
with quick fit connectors

Ref. 16100018

Units.1

17

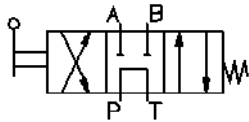

**4/3 manual acting valve,
spring centered**

P-T connected at centered
position, NG06 valve onto
base plate with quick fit
connectors

Ref. 16100019

Units.1

18



**Workbook with theory and
practices**

Ref. 01506991

Units.1

Every valve size will be NG06 – Cetop 3.

Every hydraulic connection will use anti-leakage quick-fit ecologic connectors

Hydraulics level 2

Ref. 53952016

1



Double action cylinder
 $\varnothing 32 / \varnothing 16 \times 200$ mm stroke.
 Over plate with cam and quick fit connectors
Ref. 16100023 **Units.1**

2



Set of 10 hoses with quick female connectors
 8 hoses NW6 x 500 mm length
 2 hoses NW6 x 1000 mm
Ref. 13025795 **Units.1**

3



Pressure reducing valve, 3 ways
 2...64 bar, NG06 valve onto base plate and quick fit connectors
Ref. 16100020 **Units.1**

4



Pressure relief valve, 3 ways, sequence valve.
 2...64 bar, NG06 valve onto base plate and quick fit connectors
Ref. 16100021 **Units.1**

5



Pilot operated relief valve
 Ventable (B), pilot operated, balanced piston relief valve, onto base plate and quick fit connectors
Ref. 16100022 **Units.1**

6

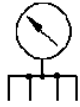

4 connections distributor on manifold with pressure gauge 0 -60 bar

Glycerin damped, on base plate with quick fit connectors

Ref. 13025741

Units.1

7

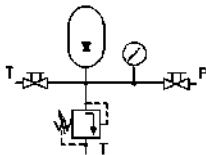

Hydraulic diaphragm accumulator with T.U.V. safety certificate

2 manual valves and a relief security valve. $V=0,7 \text{ dm}^3$, Nitrogen pressure 20 bar

Ref. 13025790

Units.1

8



Hydraulic motor

Bi-directional, internal gear, with shaft wheel. $12,5 \text{ cm}^3/\text{rev}$

Ref.13025802

Units.1

9

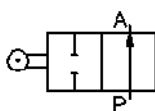

2/2 valve, ball actuated, spring return

With acting cam for $\varnothing 32$ cylinder rod

Ref. 16100024

Units.1

10

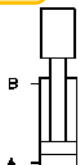

Counter-weight 17 Kg

To be fixed on one of the trolley sides It includes a double effect cylinder $\varnothing 20/\varnothing 12$, 150 mm stroke in order to make traction/compression exercises. Transparent protection screen

Ref. 13026580

Units.1

Every valve size will be NG06 – Cetop 3.

Every hydraulic connection will use anti-leakage quick-fit ecologic connectors

Every component will be suitable for working on panels with $\varnothing 17$ mm holes every 50mm (horizontally and vertically).

Hydraulics complementary

1



Single action cylinder

Ø32 / Ø16 x 160 mm stroke
Spring return. Over plate with cam and quick fit connectors
Ref. 13026563 **Units. 1**

2



Double rod cylinder.

Ø16 x Ø32 x Ø16 mm stroke,
with two acting cams. Over plate with quick fit connectors
Ref. 13025796 **Units. 1**

3

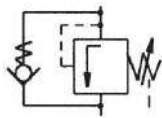

Pressure relief valve, 3 ways, sequencer valve with check valve

Direct operated, 2...64 bar,
NG 06 valve onto base plate
Ref. 16100025 **Units. 1**

4

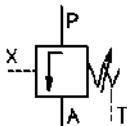

Pressure relief valve, 3 ways, with external pilot

Direct operated, 2...64 bar,
NG06 valve onto base plate
Ref. 16100026 **Units. 1**

5

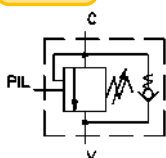

Counterbalance valve

Overcenter - Cartridge valve
inserted in a block with quick fit connectors
Ref. 17431 **Units. 1**

6

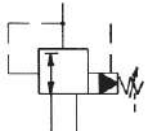

Pressure reducing valve, prepiloted

Pilot controlled pressure reducing valve. 2...64 bar, onto base plate

Ref. 16100031

Units. 1

7

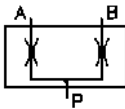

Flow divider

Flow divider valve, equal flows.
Max flow=38 l/min.

Ref. 13026562

Units. 1

8

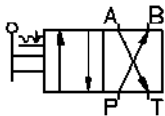

4/2 manual acting valve, with mechanical detent

NG06 valve onto base plate

Ref. 16100027

Units. 1

9

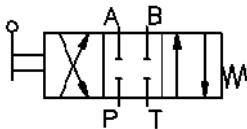

4/3 manual acting valve, closed centres, spring centered

A, B, P, T closed at centered position, NG06 valve onto base plate

Ref. 16100028

Units. 1

10

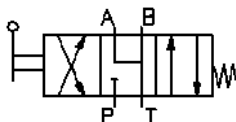

4/3 manual acting valve, A, B, T in discharge, spring centered

In central position A, B and T are linked. NG06 valve onto base plate

Ref. 16100029

Units. 1

11

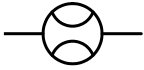

Optical flowmeter

Graduated scale, range 0,5 - 9 l/min. With quick fit connectors

Ref. 13026810

Units. 1

12



Unitary hoses, with two quick-fit self-sealing female couplings

Size DN 06, different lengths

Ref. 033857 length. 600 mm.

Ref. 031341 length. 1000 mm.

13

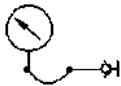

Pressure gauge with minimesse outlet

Range 0 – 60 bar, with magnetic support and 0,5m minimesse hose

Ref. 13023477

Units. 1

14

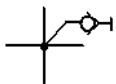

Cross distributor with minimesse

Four quick fit connectors

and one minimesse outlet

Ref. 13025801

Units. 1

15



Y distributor

Three connections with quick fit connectors

Ref. 13025812

Units. 1

16

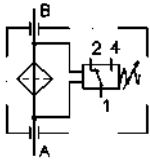

Pressure filter

Pressure filter with clogging indicator and connection cable. 10µ cartridge

Ref. 13025807

Units. 1

17

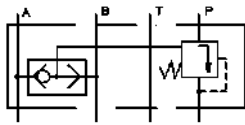

Pressure balance

Modular assembly under distribution valve NW06.

$\Delta p = 5 \text{ bar.}$

Ref. 13018774

Units. 1

18



Pressure compensated flow regulator of 3 ways

Manual regulation, $Q_{max} = 3,2 \text{ l/min.}$, onto base plate with quick fit connectors

Ref. 16100033

Units. 1

19

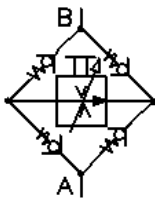

Pressure compensated flow regulator of 2 ways over rectifier bridge

Manual regulation, $Q_{max} = 3,2 \text{ l/min.}$, onto base plate with bridge

Ref. 16100034

Units. 1

20

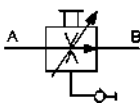

Pressure compensated flow regulator of 2 ways with minimess outlet

Manual regulation, $Q_{max} = 3,2 \text{ l/min.}$, onto base plate with quick fit connectors

Ref. 16100032

Units. 1

21



Digital flowmeter – thermometer
Parametrizable with keyboard and display. Output, digital output and I/O link. Flow or temp reading.

Ref. 38872

Units. 1

22



Sensocontrol diagnostic case

For measurement of magnitudes in a hydraulic system: Pressure Δp , Temperature, RPM and Flow
Composed of a “plug and work” measurement unit with automatic sensor recognition (2 simultaneous channels) Sensors adapted with quick connectors and with reading-acquisition software of data

Ref. 01522078

Units. 1

23



Device for control and filling of nitrogen in accumulators

Case with pressure gauges (low/high), flexible pipe with unions, block with regulation valve, gasket kit

Ref. 01006601

Units. 1

24



Nitrogen bottle + Pressure reducer

Load pressure 150 bar, volume 5 liters

Ref. 01507509

Units. 1

25

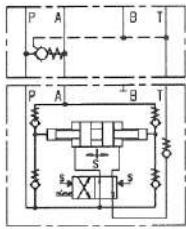

Pressure multiplier 1:4

Dynamic, with piloted non-return for By Pass. On plate with 3 quick couplings

Ref. 16100030

Units. 1

26



Block with 4 cartridge valves

It incorporates the following hydraulic functions:

- Throttle valve
- Limiting valve
- Non-return
- Piloted non-return

Block with handles, on a base plate for adaptation to a panel with zero leak quick couplings

Ref. 13028085

Units. 1

27



2/2 cartridge valve block, control by solenoid valve 4/3

Block with function: valve 4/3 NG10 closed centers, pilot control by 4/3 NG06 P,A and B communicated

Block with handles, on a base plate for adaptation to a panel with zero leak quick couplings

Ref. 13028086

Units. 1

All components incorporate ecological, anti-drip, self-sealing quick couplings. The components incorporate anodized aluminum base plates, with a panel fastening system with holes from Ø17 to 50x50 mm.

Do not hesitate to ask us for any other element or additional valve, more complementary elements are available with different configurations / controls to those shown in this catalogue

Electro Hydraulics level 1

Ref. 53952017

1



Power supply unit.

110-220 VAC/24 VDC, I=5 A. Over load and short circuit protection

On/Off switch

On/Off indication lamp

Electronically stabilized

Ø=4 mm electronic quick connectors

Plastic box with printed transparent cover

Ref. 23500965

Units.1

2



Control panel with timer

4 push buttons, 2 green, 1 red, 1 yellow, with 1 normally open + 1 normally closed contacts each

1 switch with 1 normally open + 1 normally closed contacts

1 connection / disconnection electronic timer, 0 to 6 second regulation

4 spark suppressing diodes

4 indicator lights, 2 green, 1 red and 1 yellow

Ø=4 mm quick connectors

Ref. 23500966

Units.1

3



Limit switch, with 1 normally closed contact + 1 normally opened contact

Acting by retractable roller, activation direction selectable

Ø=4 mm female connectors

Ref. 13019696

Units.3

4



Relays module

3 relay unit with 4 switched contacts each

On/Off light indicator on every relay solenoid

Spark suppressing diode on every solenoid

6 connection divider for + voltage

6 connection divider for - voltage

Ø=4 mm quick connectors

Plastic box printed transparent cover

Ref. 23500968

Units.1

5



Set of connection cables

14 blue cables, 50 mm length

14 red cables, 50 mm length

8 blue cables, 150 mm length,

8 red cables, 150 mm length.

With Ø4 mm male quick connectors

Ref. 23500081

Units.1

6

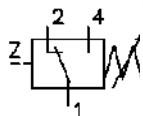

Adjustable pressure switch

Max. Pressure=40bar

Output signal by exchanged (switched) contact

Ref. 14009140

Units.1

7



Cable + connector for pressure switch

Male Ø=4 mm quick connectors

Cable length = 1,5 m

Ref. 23500079

Units.1

8

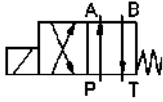

4/2 solenoid valve, 24Vdc solenoid and spring return

NG6 size valve, assembled on base plate with quick fit ecologic connectors

Ref. 16100036

Units.1

9

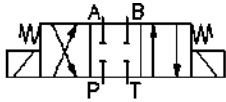

4/3 solenoid valve, 24Vdc solenoids and spring centered

A, B, P and T closed in centered position. NG6 size valve assembled on base plate with quick fit ecologic connectors

Ref. 16100037

Units1

10



1 Connector for solenoid
Including solenoid 2P+G connector, on/off indicator lamp, cable and male $\varnothing=4$ mm quick connectors

(3 units: 2 black and 1 white)

Ref. 23500025

Units.3

11



Electro hydraulics workbook with theory and practice

Ref. 01506992

Units.1

Every valve size will be NG06 – Cetop 3.

Every hydraulic connection will use anti-leakage quick-fit ecologic connectors

Every component will be suitable for working on panels with $\varnothing 17$ mm holes every 50mm (horizontally and vertically).

The electrical components are provided with $\varnothing 4$ mm quick-connect sockets

Electro Hydraulics level 2 – Modular Blocks 1 – 4

1



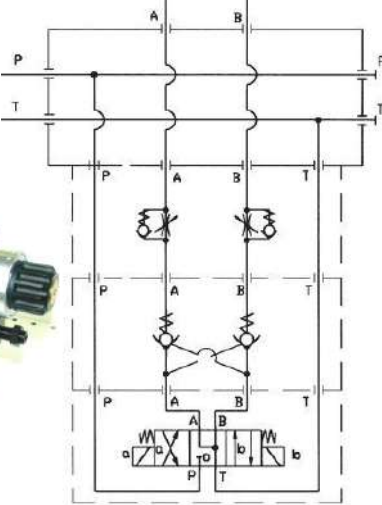

Position & flow control
Composed by:

- Solenoid valve 4/3 (A,B to T)
- Mod. piloted double non-return
- Double throttle module with non-return valve
- Base plate with four self-sealing quick connectors
- Two connectors with led, cable with plugs for solenoids

Ref. 5395201 **Units. 1**

2



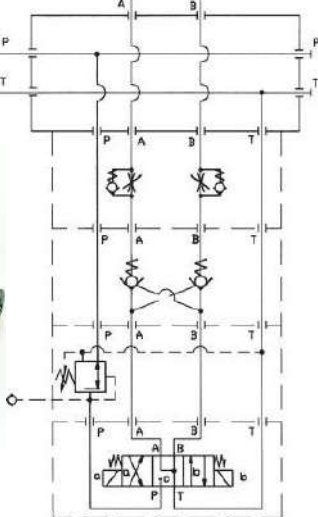

Position, flow & pressure control
Composed by:

- Solenoid valve 4/3 (A,B to T)
- Mod. piloted double non-return
- Double throttle module with non-return valve
- Modular pressure reducer
- Base plate with four self-sealing quick connectors
- Two connectors for solenoids

Ref. 5395202 **Units. 1**

3



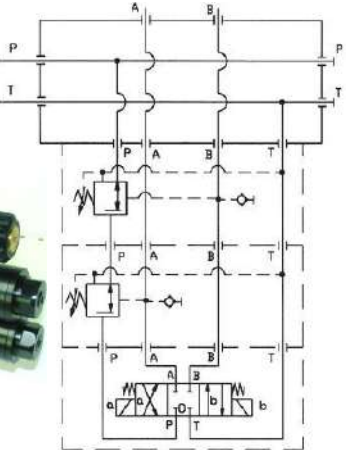

Independent control of pressure at both working directions
Composed by:

- Solenoid valve 4/3 (CC)
- Modular pressure reducer, controlled from A, with minimess
- Modular pressure reducer, piloted from B, with minimess
- Base plate with four self-sealing quick couplings
- Two connectors for solenoids

Ref. 5395203 **Units. 1**

4

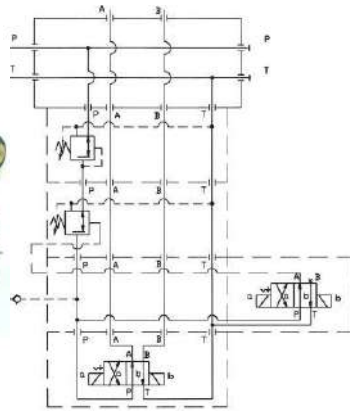

Two independent pressures selection

- Composed by:
- Two 4/2 solenoid valves with mechanical interlock
 - Modular pressure reducer
 - Modular pressure reducer, with external pilot
 - Command block, with minimess
 - Motherboard with four sockets
 - Two connectors for solenoids

Ref. 53952024

Units. 1

Electro Hydraulic – Other Modular Blocks 5-9

Single Ref.

5

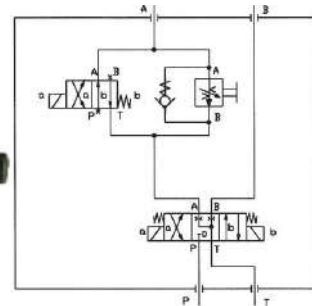

Quick / slow speed change with secondary regulation

- Composed by:
- Solenoid valve 4/3 (A,B to T)
 - 4/2 monostable solenoid valve
 - Compensated flow regulator with anti-return
 - Control block
 - Motherboard with four sockets
 - Three connectors for solenoids

Ref. 53952025

Units. 1

6

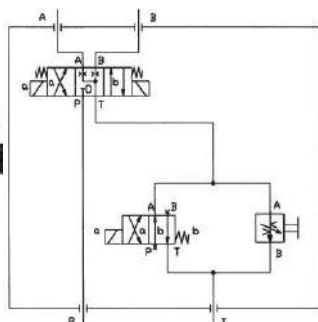

Quick / slow speed change at both working directions

- Composed by:
- Solenoid valve 4/3 (A,B to T)
 - 4/2 monostable solenoid valve
 - Compensated flow regulator
 - Control block
 - Motherboard with four sockets
 - Three connectors with led, cable and plugs for solenoids

Ref. 53952026

Units. 1

7

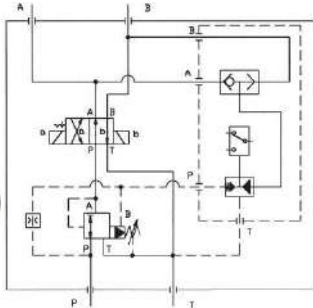

Pressure regulation with automatic pressure control by using self-regulating pressure switch

Composed by:

- 4/2 solenoid valve with mechanical interlock
- Preactuated pressure reducer
- Pressure switch with self-regulation. With connector and cable
- Base plate with four quick connectors
- Two connectors with led, cable and plugs for solenoids

Ref. 53952027

Units. 1

8

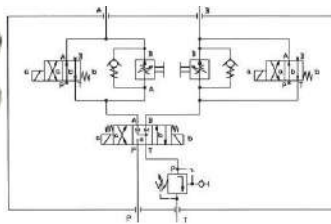

Quick / slow speed change, independent in both working directions, with primary regulation and counter-pressure

- 4/3 solenoid valve (A,B to T)
- Two 4/2 solenoid valve single state
- Two compensated flow regulators with anti-returns
- Modular back pressure valve
- Control block
- Motherboard with 4 sockets
- Four connectors for electromagnets

Ref. 53952028

Units. 1

9

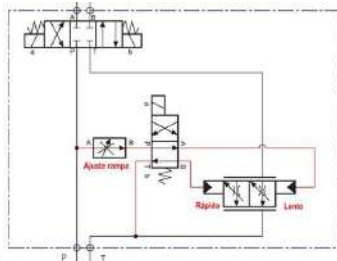

Pre-proportional hydraulics: Quick / slow speed change control with ramp regulation

Valve block that allows two speeds: quick/slow, with ramp adjustment, time to pass from one speed to another. Base plate with four quick connectors

- Three connectors with led, cable and plugs for solenoids

Ref. 16100060

Units. 1

Electro hydraulics complementary

Single Ref.

1

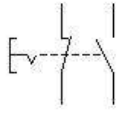

Emergency push button

Push button with interlocking, with 1NO contact and 1 NC contact. Ø4mm sockets

Ref. 23500952

2

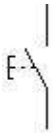

Electric push button NO

Push button green color (start), with 1NO contact. Ø4mm sockets

Ref. 23500953

3

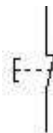

Electric push button NC

Push button black color (stop), with 1NC contact. Ø4mm sockets

Ref. 23500954

4



Electric switch

Electric switch, rotary actuation, black color (auto). Ø4mm sockets

Ref. 23500923

5

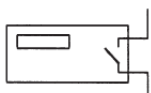

Up/Down counter

Electronic settings, two channels: A and B. Preselection value and reset can be manual or electric. Output: 1 switched contact, Ø4mm sockets

Ref. 23500956

6

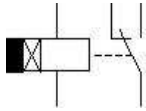

Electronic timer

Selectable connection / disconnection time. Setting by potentiometer. Ø4mm sockets
Ref. 23500957

7

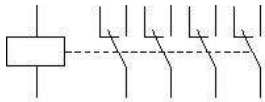

Relay module

24Vdc relay, with 4 switched contacts. Ø4mm sockets
Ref. 23500955

8

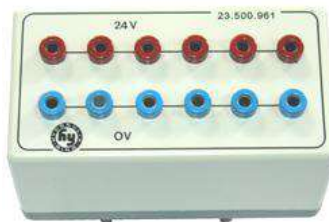

Electrical distributor module

6 red connection Ø4mm sockets (24V) and 6 blue connection Ø4mm sockets (0V)
Ref. 23500961

9

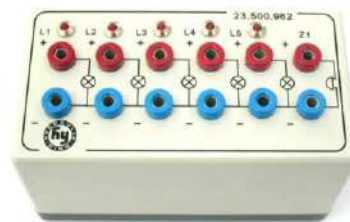
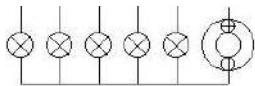

Indicator module

With 5 LED lights and 1 buzzer, Ø4mm sockets activations at 24Vdc
Ref. 23500962

10

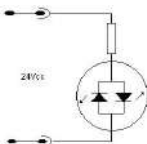

1 connector + cable for solenoid

solenoid's connector 2P+T, led and cable with two Ø4mm plugs
Ref. 235000025

11

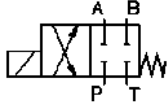

4/2 solenoid valve, 24Vdc solenoid and spring return

Closed centers in off state. NG6 size valve, assembled on base plate with quick fit ecologic connectors

Ref. 16100038

12

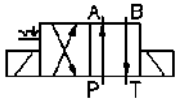

4/2 solenoid valve, 24Vdc solenoids with mechanical interlocking

NG6 size valve, assembled on base plate with quick fit ecologic connectors

Ref. 16100039

13



4/3 solenoid valve, 24Vdc solenoids and spring centered

In central position A and B to tank. NG6 size valve assembled on base plate with quick fit ecologic connectors

Ref. 16100040

14

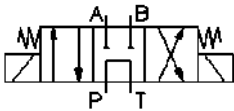

4/3 solenoid valve, 24Vdc solenoids and spring centered

In central position P to tank. NG6 size valve assembled on base plate with quick fit ecologic connectors

Ref. 16100041

15

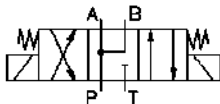

4/3 solenoid valve, 24Vdc solenoids and spring centered

In central position A, B and P linked. NG6 size valve assembled on base plate with quick fit ecologic connectors

Ref. 16100053

16

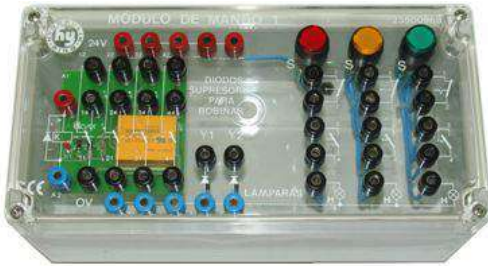

Control unit and relay

3 push buttons, 1 green, 1 red, 1 yellow, with 1 normally open + 1 normally closed contacts each

1 relay, with 4 switched contacts.

1 electrical distributor: 5 red (24V) and 5 blue(0V) connection sockets

2 spark suppressing diodes

3 indicator lights, 1 green, 1 red and 1 yellow

Ø=4 mm quick connectors

Ref. 23500969

17



PLC's on rack

Programmable logic controllers from the main manufacturers on the market.

Different models and I/O configurations of Siemens, Omron..

Ask for the requirements

Ref. PLC's on rack

18



Automation Studio design and simulation software

Powerful software for the design and simulation of circuits with different automation technologies.

Different packages: Pneumatics, Hydraulics, Fluid Power, Electrotechnics, Automation, Premium

Ask for the licenses

Ref. AStudio

20

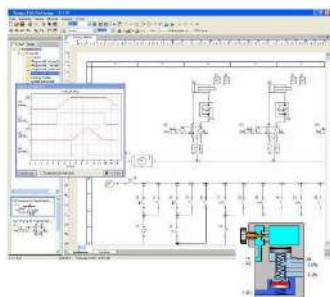

HRE OFT software

Friendly software for the desing and simulation of electro- hydraulics, and electro pneumatics circuits. Available packages: Pneumatics, Hydraulics and Fluid Power (Pneumatics and hydraulics).

Ask for the licenses

Ref. HRE OFT

Proportional hydraulics level 1

Ref. 53952018

1



Electronic control for proportional valves

Basic electronic control for two proportional solenoids I_{max}:0,8A
Current regulation by potentiometer and display by ammeter (one per coil). Possibility of introducing Dither signal to improve hysteresis.

Plastic box with printed transparent cover and Ø=4 mm quick connectors

Ref. 23500970

Units. 1

2



Set of 2 connectors with LED

Progressive lighting of the LED according to the current intensity With cable and Ø4mm plugs

Ref.23500036

Units. 1

3



Force measuring device.

Proportional coil on precision electronic scale to measure the force it exerts

Ref. 13026571

Units. 1

4

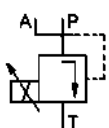

Proportional pressure relief valve

Direct command. Pressure regulation range from 0 to 60 bar. On plate with 3 quick couplings

Ref.16100049

Units. 1

5



4/3 Proportional distributor valve, NG06

Directly operated by 24Vdc(0,8A) solenoids, closed centres, spring-centring. On base plate with quick fit ecologic connectors

Ref.16100048

Units.1

6



4/3 Proportional distributor valve NG10 precontrolled.

Indirectly operated, closed centres, spring-centring. On base plate with quick fit ecologic connectors

Ref.16100050

Units.1

7

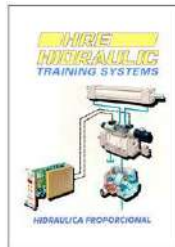

Workbook with theory and practices

Proportional Hydraulics

Ref. 01506994

Units.1

Every hydraulic connection will use anti-leakage quick-fit ecologic connectors

Every component will be suitable for working on panels with Ø17 mm holes every 50mm (horizontally and vertically).

Proportional hydraulics level 2:

Ref. 034915

APPLICATIONS OF POSITION, SPEED AND FORCE CONTROL OF A HYDRAULIC DRIVE

A single parameterizable controller for the different practices

1



Closed / Open loop controller PZD-PWD

Microprocessor based electronic cards for configuration, parameterization and on-line monitoring of servo hydraulic systems. The same control is used for every exercise, internal (6) / external setpoint values (analog input: +/- 10V or 4-20mA), acceleration / deceleration ramps, PID digital controller. Assembled and totally wired to base plate with printed plate and $\varnothing=4\text{mm}$ quick connectors

Ref. 23505019

Units.1

2

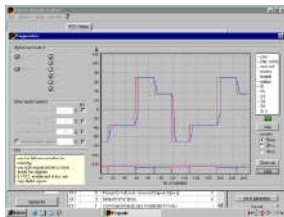

Pro-PxD software

It allows a comfortable parameter setting for the PZD-PWD controller. Parameters can be saved or downloaded. Online connection with plotting functions for commands and feedback

Ref. ProPXD

Units.1

3



Workbook with practices

Proportional hydraulics applications

Ref. 01522012

Units.1

Proposed exercises

Exercise 1: Ramp speed control of a linear actuator in open loop – Page 30

Exercise 2: Speed control by ramps of a linear actuator in internal closed loop – Page 30

Exercises 3/4: Speed control of a rotary actuator in open loop / closed loop – Page 31

Exercise 5: Position control of a linear actuator in closed loop – Page 31

Exercise 6: Angular position control of rotary actuator in closed loop – Pages 31 (loose element) and 32

Exercises 7/8: Different working pressures: Closed / open loop pressure control – Page 32

4



Double rod cylinder.

Ø16 x Ø32 x Ø16 mm stroke, with two acting cam. Over plate with quick fit connectors

Ref. 13025796

Units. 1

5

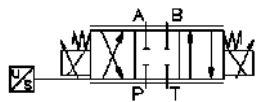

4/3 propotional valve with LVDT.

Directly operated by solenoids and spring centered, closed centres, with position sensor (LVDT). NG06 valve on base plate with quick fit ecologic connectors

Ref.16100047

Units. 1

6

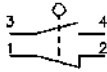

Limit switch, with 1 NC + 1 NO contact

Acting by retractable roller, activation direction selectable
Ø=4 mm female connectors

Ref. 13019696

Units.1

7



Relay module

3 relay unit with 4 exchanged (switched) contacts each On/Off light indicator on every relay solenoid

Spark suppressing diode on every solenoid

6 connection divider for 24Vdc

6 connection divider for 0Vdc

Ø=4 mm quick connectors

Plastic box printed transparent cover

Ref. 23500968

Units.1

8

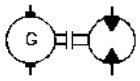

Hydraulic motor with speed transducer

Dynamometric sensor assembled to hydraulic motor, analog output 0 -/+ 10Vdc On base plate with quick fit ecologic connectors

Ref. 30097

Units.1

9



Rotary position sensor (loose).

Includes mechanical couplings to attach to the motor shaft of the equipment level 2 (motor's Ref 13025802)

Ref. 23500994

Units.1

10

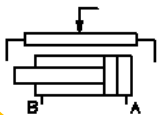

Cylinder with position transducer

Double effect, Ø32 x Ø22 stroke 200mm. Assembled onto base plate with quick fit ecologic connectors

Ref. 20734

Units.1

11

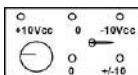

External set-point value generator

Output 0 +/- 10 Vdc with rotating joystick. In plastic box with Ø=4mm plugs and signal switch selection

Ref. 21503701

Units.1

12



Digital pressure transducer

With display, pressure range: 0-60 bar, parameterization functions and pressure settings, 2 digital outputs and 1 analog output 0...20mA / 4...20mA On base plate with quick connectors

Ref.13026568

Units.1

13

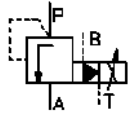

Proportional pressure relief valve

Pilot operated relief valve with proportional adjustment: 4-64bar
Nominal flow=40 l/min. NG06 valve on base plate with quick connectors

Ref. 16100046

Units.1

Every valve size will be NG06 – Cetop 3.

Every hydraulic connection will use anti-leakage quick-fit ecologic connectors

Every component will be suitable for working on panels with Ø17 mm holes every 50mm (horizontally and vertically).

The electrical components are provided with Ø4 mm quick-connect sockets

Proportional hydraulics accessories / complements

Single Ref.

1

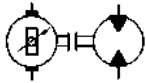

Hydraulic motor with position

transducer Rotary potentiometer sensor assembled to hydraulic motor, analog output 0...10Vdc. On base plate with quick fit ecologic connectors

Ref. 38848

Units.1

2

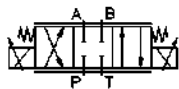

4/3 Proportional distributor valve,NG06

Directly operated by 9Vdc(2,7A) solenoids and spring centered, closed centres, on base plate with quick fit ecologic connectors

Ref.16100051

Units.1

3

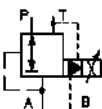

Proportional pressure reductor valve

Pilot operated reductor valve with proportional adjustment: 4-64bar
Nominal flow=40 l/min. NG06 valve on base plate with quick connectors

Ref. 16100045

Units.1

4

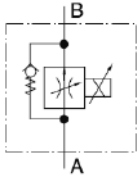

Proportional flow control valve

With pressure compensation and check valve. Nominal flow = 3,2 l/min, NG06. On base plate with quick connectors

Ref. 16100043

Units.1

5

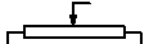

Position sensor (loose).

Potentiometer over plate base, with assembly kit for cylinder level 1 (Ref. 13025799)

With connector, cable and Ø=4mm plugs

Ref. 23500995

Units.1

6



Speed transducer (loose).

Includes mechanical couplings to attach to the motor shaft of the equipment level 2 (motor's Ref 13025802)

Ref. 23500996

Units.1

7

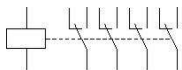

Relay module

Relay unit with 4 exchanged (switched) contacts. In plastic box printed with Ø=4mm plugs

Ref. 23500955

Units.1

Every valve size will be NG06 – Cetop 3.

Every hydraulic connection will use anti-leakage quick-fit ecologic connectors

Every component will be suitable for working on panels with Ø17 mm holes every 50mm (horizontally and vertically).

The electrical components are provided with Ø4 mm quick-connect sockets

Proportional hydraulics level 3:

Ref. 42093

PID CONTROLLER WORKING WITH DFplus SERVOVALVE

High dynamic proportional valve (like servo valve) DFplus with on board electronics and PID controller for applications of force, speed and position control similar to the proportional hydraulics level 2 (the actuators and the sensors of level 2 are required, only changes the DFplus valve and the PID controller)

1



DFplus servo valve

NG06 proportional valve with on board electronics and integrated VLDT for internal position closed loop. Zerolap, high dynamics - 3 dB /350 Hz at +/-5% input signal

Possibility of work in manual by analog signal (+/-10 Vcc) or in automatic mode with PID controller or MP100 numerical control (see page 36, hydraulics level 4) Connector, cable and Ø=4mm plugs, on base plate with quick fit connectors
Ref.42018 **Units.1**

2



Digital PID controller

Axis controller for position, pressure and speed in closed loop systems **working with proportional valves with on board electronics**, Parametering by serial interface RS232c and software Pro-PXD Analog setpoint values (+/- 10V or 4-20mA), acceleration / deceleration ramps, extended PID controls. Assembled and totally wired to base plate with printed plate and Ø=4mm quick connectors

Ref 41998

Units.1

3

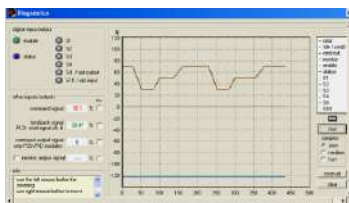

ProPxD software

It allows a comfortable parameter setting for the PID controller. Parameters can be saved or downloaded. Online connection with plotting functions for commands and feedbacks

Ref. ProPXD

Units.1

4

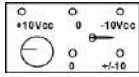

External set-point value generator

Permits directly introduce commands to PID controller

Output 0 +/- 10 Vdc with rotating joystick. In plastic box with Ø=4mm plugs and signal switch selection

Ref. 21503701

Units.1

5



Workbook with practices

Proportional hydraulics applications Vol2, with PID controller and DFplus valve

Ref. 42016

Units.1

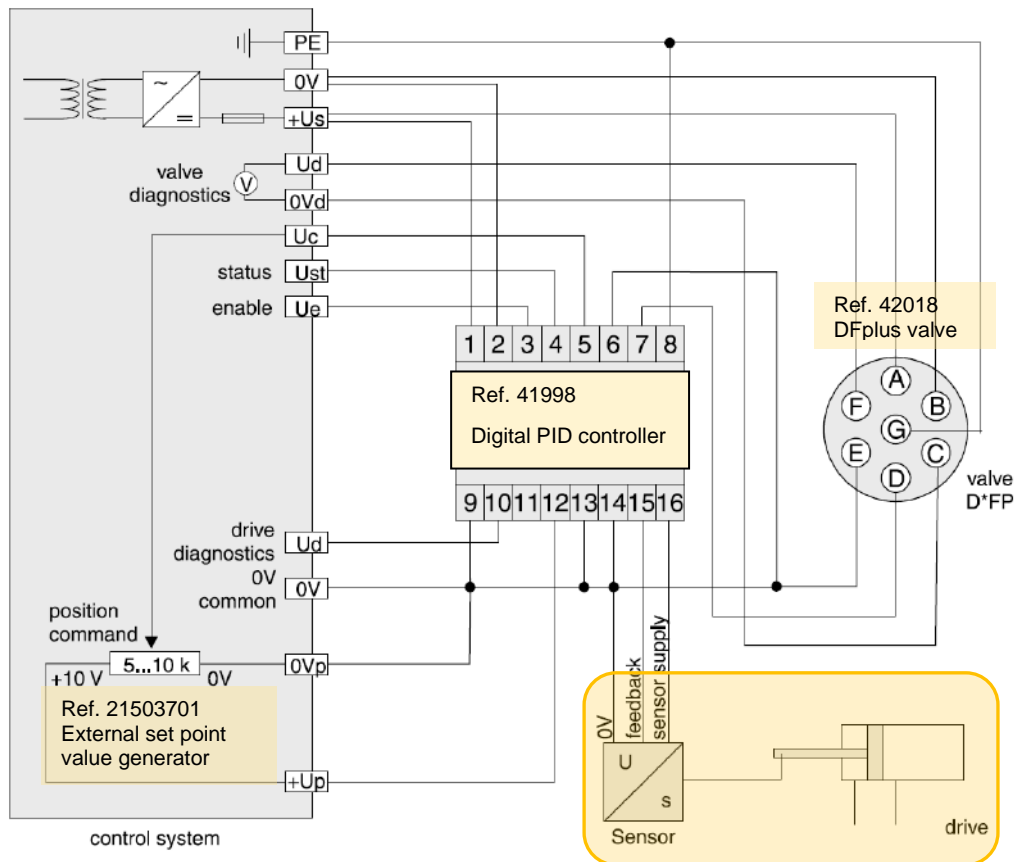

To work with the proportional hydraulics level 3 equipment, an actuator and sensor are required, available in the proportional hydraulics level 2 equipment.
(it will depend of the control: position, speed or pressure that you want to perform)

Proportional hydraulics level 4:

Ref. 42094

NUMERICAL CONTROL APPLICATION FOR HYDRAULIC AXIS

Hydraulic axis controlled by MP100 numerical control with high precision

1



MP100 numerical control

High precision hydraulic axis control application

-15 x 15 program positions, setting of speeds and time delays for the positions

-External selection of the program position

-Alfa numerical indication

-Absolute or incremental measurements

Assembled and totally wired to base plate with printed plate and $\varnothing=4\text{mm}$ quick connectors

Works in combination with "PZD-PWD controller + Proportional Valve" or with "DFplus valve"

Ref. 23505011

Units.1

2



Control module for MP100

Push buttons, indicator lamps, switches for the program number selection, selector for automatic/manual cycle... available all the connection functions of the MP100 numerical control.

In plastic box printed with $\varnothing=4\text{mm}$ plugs

Ref. 23500999

Units.1

3

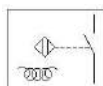

Inductive sensor, home reference

M12 proximity sensor, nominal sensing = 2mm, for searching of the home position "zero machine"

Over plate with $\varnothing=4\text{mm}$ plugs

Ref. 13024805

Units.1

4

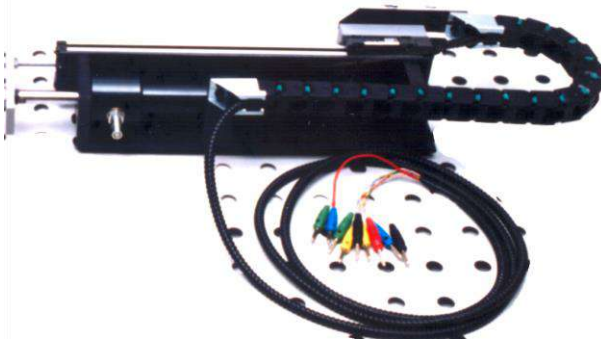

Cylinder with encoder

Set consisting of a Ø32Ø16 x 300mm steel cylinder, a 300mm linear guide with a ball slide, a 6-channel optical ruler with an articulated plastic cable holder and a Ø4mm connection plugs. On base plate with extra panel fixing system and 2 self-sealing quick connection plugs

Ref. 13026957

Units.1

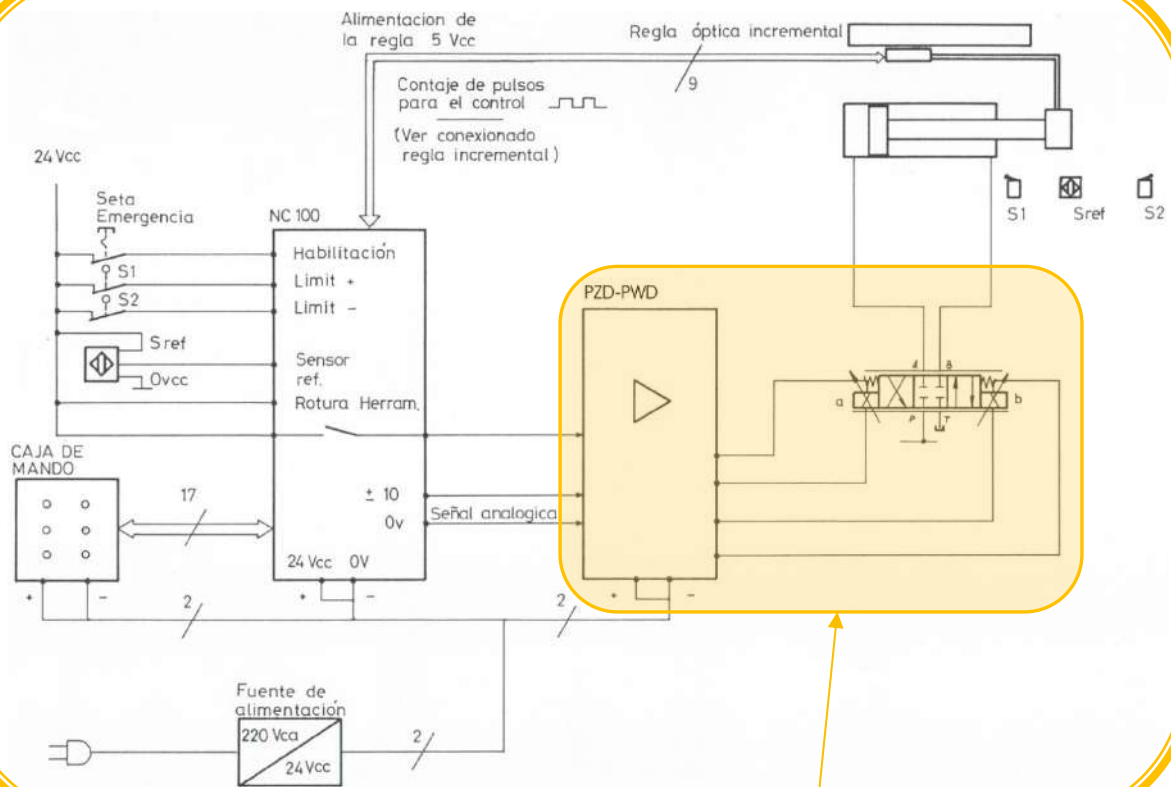

To work with the proportional hydraulics level 4, a set of “**PZD-PWD controller + proportional valve**” or “**Dfplus valve**” is required (see page 34)

The electrical components are provided with Ø4 mm quick-connect sockets

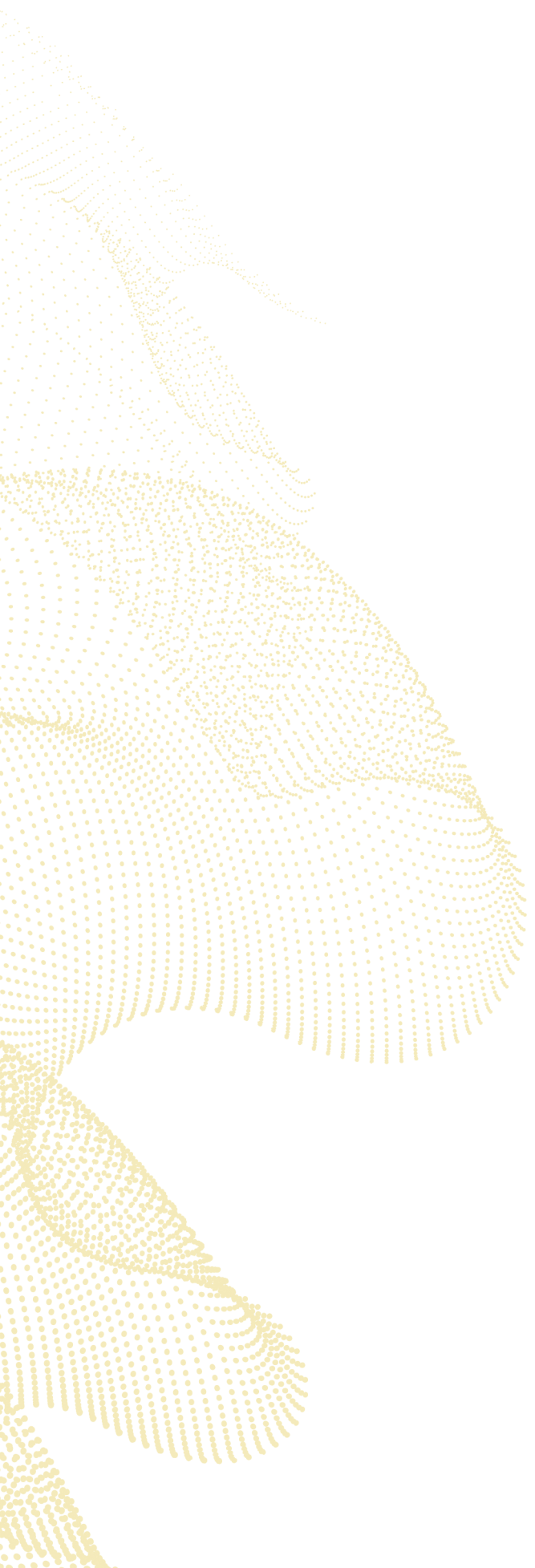

HRE
40 Years

Pol. Ibaizarte 21
20870 Elgoibar, Gip.

(+34) 943 74 21 30
hre@hre.es

www.hre.es