

TRAINING SYSTEMS

# **MECHATRONICS**

---

**HRE**  
Automation

**HRE Automation** takes advantage of its industrial experience of more than 40 years in industrial automation and fluids, using it as a technological base to create equipment and educational systems that are perfectly suited to the demands of today's industrial market.

In the continuous search for excellence in teaching equipment, we are a company specialized in providing means for optimal training in the field of automation.

We present our **MECHATRONICS** equipment:

Didactic system for learning integrated automation technologies: **PLC, ROBOTICS, SENSORICS, PNEUMATICS, HYDRAULICS, ELECTRICS, ELECTRONICS, MECHANICS**

***HRE***  
*Automation*

**HRE Automation**

C/ Ibaizarte 21  
E-20870 Elgoibar (Gipuzkoa)  
Spain



+34 943 742 130



hre@hre.es



<http://www.hre.es>

# FLEXIBLE AUTOMATION MODULES (M.A.F)

## GENERALITIES

The objective of this system is that automation training has a strong practical component and the different technologies (pneumatics, hydraulics, electronics, sensors, PLC's, robotics, industrial communications, etc.) are studied in an integrated way, to allow the student develop a global vision of automation technology.

In this way, it is intended to respond to the growing complexity of manufacturing systems that makes continuous and intensive training necessary in the areas of:

- \* Desing
- \* Assembly
- \* Programming and planning
- \* Start up
- \* Control of production lines
- \* Maintenance
- \* Industrial communications

Each station can work independently or in combination with others. It is intended that several groups of students work "simultaneously", each with a module and its PLC, and finally to have a common setting that allows the assembly of complete lines. This makes the system extremely flexible by allowing "all students" to work at the same time.

The delivered documentation divides the complete work cycle of each module into simple tasks to solve - practical exercises, proposed in the work manual, that the student gradually tackles, which considerably improves the understanding of the control techniques used..

## THE PROPOSED MODULES

*HRE Automation* offers a system in which many more elements and techniques are studied, such as

- : - Pneumatics
- Mechanics
- Electrics
- Electronics
- Sensorics
- PLC's
- Industrial communications
- Robótica ...

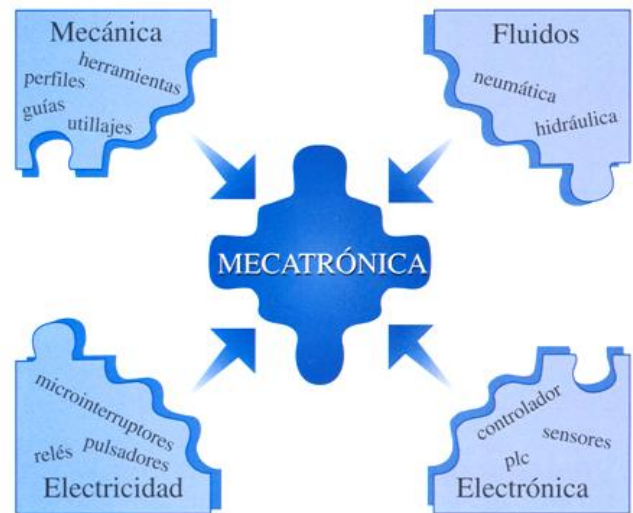

What is equivalent to a complete **MECHATRONICS** equipment and that, at the same time, can be easily expanded in the future:

In our proposals the concept of "Modularity" predominates. Thanks to its small size, it allows to have several modules on a table or work surface, combine the various modules or physically remove them from the assembly to work as a self-contained unit. For which, each module can be equipped with its own programmable PLC (or they can be whatever the school has, adapting the signals from the module's DB25 connector), and perform different exercises individually to become familiar with each MAF modular unit

When the optimal operation of each module has been achieved, two or more can be joined to complete more complex work cycles.

Instead of preparing "toy models", all the elements used (sensors, buttons, cylinders, valves, automatons, etc.) are industrial, robust and of recognized prestige brands., of very common use in the industry, which allows the student to work with real equipment, resistant and similar to those that he will find in his professional work

**MAF-505**  
**GRAVITY FEEDER**

Flexible Automation Module “Gravity Feeder”, ready to work directly with a PLC, initially individually and later combining it with other modules to carry out a manufacturing/automation process.

The module is made up of 1 vertical warehouse that is filled with round pieces. Designed to accept 30mm cylinders. in diameter of different materials (aluminum, black and white plastic). The extraction of the pieces towards the collection plate is carried out with a double-acting cylinder Ø20 mm. provided with 2 magnetic detectors for position control. The filling level is detected by a light barrier (or optional capacitive detector). The presence of a part on the collection plate will be detected by an electromechanical micro-switch.

The station is mounted on an aluminum base, measures 160 x 400 x 340 mm. Weight 2kg

Training and learning:

Designed for the study of pneumatic and electro-pneumatic technologies, as well as cylinder position detection by reed detector (magnetic), part extraction, part presence, light barrier, PLC programming, interpretation of diagrams and schematics, fault location and repair, safety and emergency conditions, mechanical, electrical and pneumatic commissioning.

**Technical data:**

**Construction:** \*F-subplate 160 x 400mm.

- \*Connection interface
- \*Manifold valve unit
- \*Move out cylinder
- \*2 Slides: horizontal/vertical

**Actuator:** 1 double acting cylinder Ø20x30 mm. with 2 one way flow restrictors

**Electro valve:** 1 5/2-way valve, bistable, 24Vdc, with leds and manual push buttons

**Sensors:** 2 magnetic "reed" sensors  
1 micro swithc  
1 one way light barrier

**PLC wirings:** Digital inputs / outputs 4DI / 2DO

**Interface**

Interface box with SUB-D 25 pin connector



**Combinations**

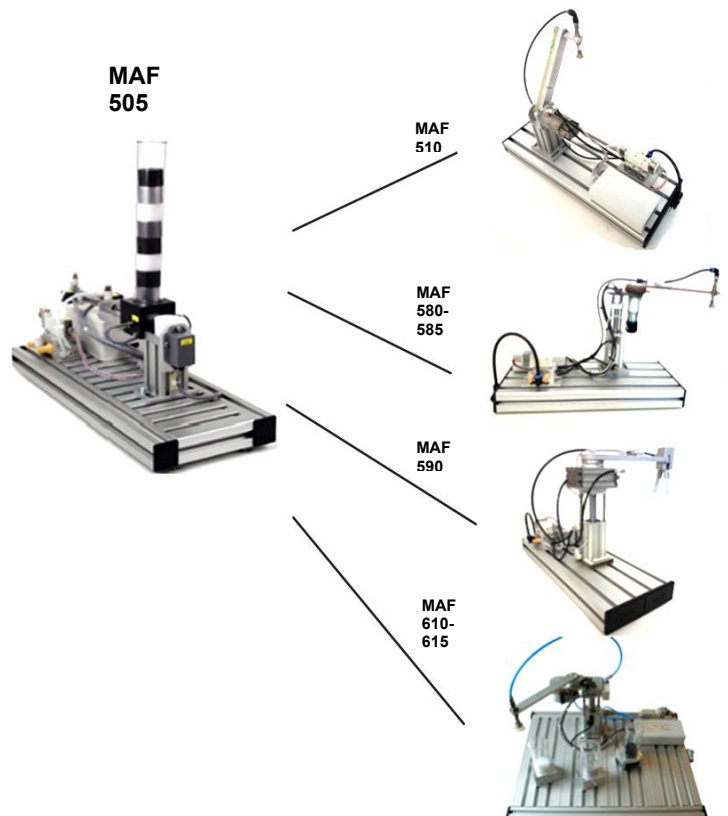

## MAF-500 - GRAVITY FEEDER WITH PART DETECTION

Flexible Automation Module "Gravity Feeder With Part Detection", ready to work directly with a PLC, initially individually and later combining it with other modules to carry out a manufacturing/automation process.

The module is made up of 1 vertical warehouse that is filled with round pieces. Designed to accept 30mm cylinders. in diameter of different materials (aluminum, black and white plastic). The extraction of the pieces towards the collection plate is carried out with a double-acting cylinder Ø20 mm. provided with 2 magnetic detectors for position control. The filling level is detected by a light barrier (or optional capacitive detector). The presence of a part on the collection plate will be detected by an electromechanical micro-switch. The type of part is defined by the combination of optical and inductive sensors

The station is mounted on an aluminum base, measures 160 x 400 x 340 mm. Weight 2kg

### Training and learning:

Designed for the study of pneumatic and electro-pneumatic technologies, as well as cylinder position detection by reed detector (magnetic), part extraction, part presence and type, sensors, light barrier, PLC programming, interpretation of diagrams and schematics, fault location and repair, safety and emergency conditions, mechanical, electrical and pneumatic commissioning.

### **Technical data:**

**Construction:** \*F-subplate 160 x 400mm.

\*Connection interface

\*Manifold valve unit

\*Move out cylinder

\*2 Slides: horizontal / vertical

**Actuator:** 1 double acting cylinder Ø20x30 mm. with 2 one-way flow restrictors

**Electro valve:** 1 5/2-way valve, bistable, 24Vdc, with leds and manual push buttons

**Sensors:** 2 magnetic "reed" sensors

1 micro swithch

1 one way light barrier

1 optical sensor

1 inductive sensor

**PLC wiring:** Digital inputs / outputs 6DI / 2DO

**Interface** Interface box with SUB-D 25 pin connector

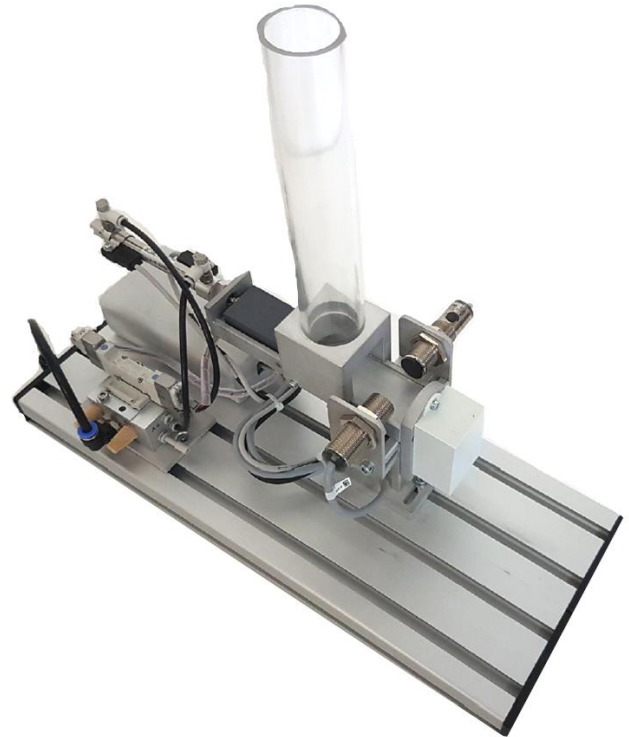

### Combinaciones

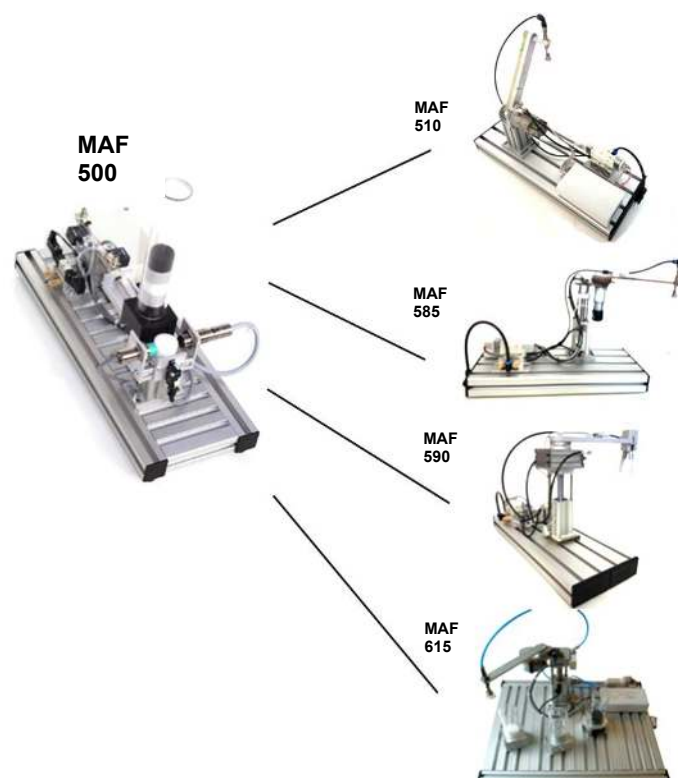

## MAF-510 SWIVEL UNIT

Flexible Automation Module "Swivel Unit", ready to work directly with a PLC, in the beginning individually (Pick and Place) and later combining it with other modules to carry out a manufacturing/automation process.

The unit is provided with a 160mm swivel arm, driven by a rotating cylinder, equipped at its final end with a suction cup with a vacuum generator, which allows the transport of the extracted pieces from the collection plate of the previous station to the drop plate of the rear station. Rotary movement controlled by 5/3 solenoid valve, adjustable range (180°), with position detection by 2 reed sensors.

The station is mounted on an aluminum base, measures 160 x 400 x 340 mm. Weight 2.1 kg

### Training and learning:

Transport mechanics of the "pick and play" swivel arm, the study of pneumatic and electro-pneumatic technologies, position detection of the rotating unit by "reed" sensors (magnetic), vacuum generation, PLC programming, interpretation of diagrams and schematics, fault location and repair, safety and emergency conditions, mechanical, electrical and pneumatic commissioning.

### Technical data:

**Construction:** \*F-subplate 160 x 400mm.

\*Connection interface

\*Manifold valve unit

\*Pick and place unit

\*Vacuum generator / Suction cup

### Actuator:

1 rotary cylinder, with adjustable range (180°) and speed regulation by 2 one-way flow restrictors

### Swivel arm:

1 swivel arm with suction cup on top with rotary movement by toothed belt

### Ejector:

1 vacuum generator by venturi valve connected to a suction cup

### Electro valves:

1 5/2-way valve, monostable, 24Vdc, with led and manual push button

1 5/3-way valve, NO in central position, 24Vdc, with leds and manual push buttons

**Sensors:** 2 magnetic "reed" sensors

**PLC wiring:** Digital inputs / outputs 2DI / 3DO

**Interface** Interface box with SUB-D 25 pin connector

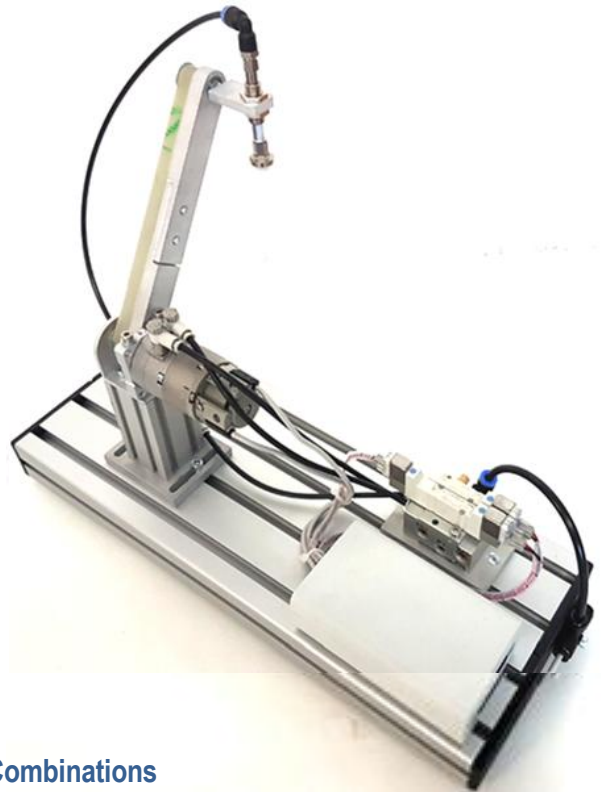

### Combinations

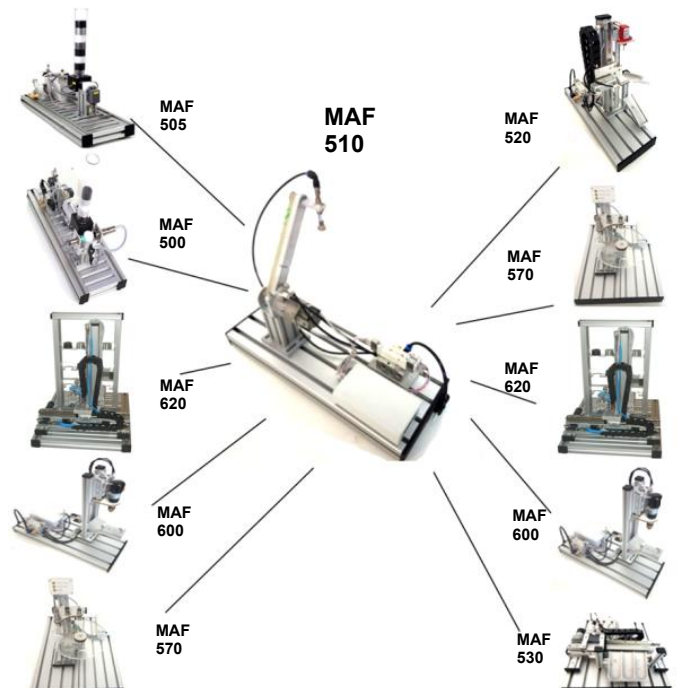

## MAF-520 ANALOG METER – TESTING STATION

Flexible Automation Module “Analog Meter – Testing Station”, ready to work directly with a PLC, in the beginning individually (analog signals) and later combining it with other modules to carry out a manufacturing/automation process.

The parts are raised in a vertical structure to the upper position against a measuring analog device that allows us to determine their thickness (0...10V signal evaluation). Depending on the part's thickness, it is taken to the intermediate position to be deposited in the next station or to the lower position for ejection by ramp.

The up/down movement of the vertical cylinder is carried out by a 5/3 solenoid valve. This cylinder has 3 “reed” sensors. The piece is ejected by a horizontal cylinder, controlled by a 5/2 monostable solenoid valve with 1 “reed” sensor.

The station is mounted on an aluminum base, measures 160 x 400 x 340 mm. Weight 5 kg

### Training and learning:

Transport mechanics of the elevator cylinder, the study of pneumatic and electro-pneumatic technologies, position detection and stopping techniques of the rodless cylinder by “reed” (magnetic) sensors, PLC programming with digital and analog values, interpretation of diagrams and schematics, fault location and repair, safety and emergency conditions, mechanical, electrical and pneumatic commissioning

### Technical data:

- Construction:**
- \*F-subplate 160 x 400mm.
  - \*Connection interface
  - \*Manifold valve unit
  - \*Vertical structure with rodless cylinder
  - \*Measuring analog device
  - \*Ejector cylinder and ramps

- Actuators:**
- 1 double acting rodless cylinder with 2 one way flow restrictors for speed regulation
  - 1 double acting cylinder Ø20x30 mm: ejector cylinder with two ramps and

speed regulation by 2 one way flow restrictors

### Testing device:

1 vertical construction, elevate by rodless cylinder, with measuring device on the top by analog signal and two ramps

- Electro valves:**
- 1 5/2-way valve, monostable, 24Vdc, with led and manual push button
  - 1 5/3-way valve, NO in central position, 24Vdc, with leds and manual push buttons

- Sensors:**
- 3 “reed” in rodless cylinder
  - 1 “reed” in ejector cylinder
  - 1 analog sensor 0...10V

**PLC wiring:** Digital inputs / outputs 4DI / 3DO  
Analog inputs: 1AI

**Interface:** Interface box with SUB-D 25 pin connector



### Combinations

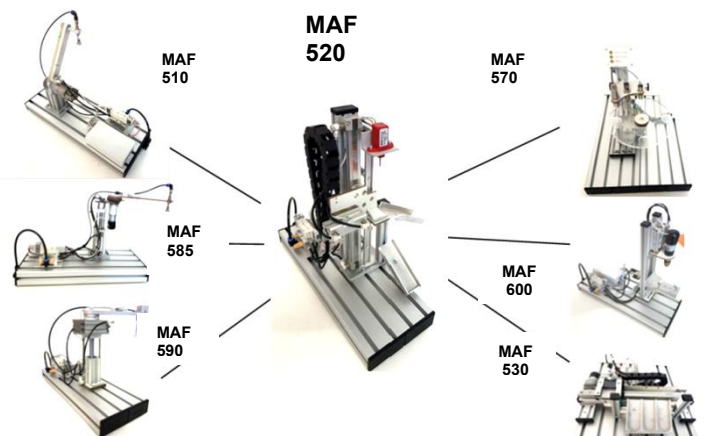

## MAF-530 SORTING STATION

Flexible Automation Module “Sorting Station”, ready to work directly with a PLC, in the beginning individually (sorting process) and later combining it with other modules to carry out a manufacturing/automation process.

The parts are moved along a linear axis to three classifying ramps depending on the type of piece and the filling level of each ramp is supervised by a light barrier.

The movement of the linear axis, which drives the workpiece carrier, is carried out by a 24Vdc electric motor and the positioning of each ramp by encoder (pulse counter) and the end positions by 2 microswitches. The parts are ejected to the classification ramp by a double-acting cylinder, controlled by a 5/2 monostable and reed detector.

The station is mounted on an aluminum base, measures 320 x 400 x 130 mm. Weight 4,2 kg

### Training and learning:

Transport mechanics of the lineal axis, the study of pneumatic and electro-pneumatic technologies, position detection and stopping / ejecting techniques, pulse counting (light fork encoder) and PLC programming, interpretation of diagrams and schematics, fault location and repair, safety and emergency conditions, mechanical, electrical and pneumatic commissioning

### Technical data:

**Construction:** \*F-subplate 320 x 400mm.  
\*Connection interface  
\*Relay control module: electric motor activation  
\*Manifold valve unit  
\*Electric lineal axis with workpiece holder and ejection cylinder  
\*Sorting ramps with filling verification by light barrier, three ramps.

**Actuators:** 1 electric lineal axis: servomotor with reduction, 24Vdc, positioning by encoder and two microswitches; activated by two outputs of relay module  
1 double acting cylinder Ø20x30 mm: ejector cylinder with speed regulation by 2 one way flow restrictors

**Sorting ramps:** 3 ramps for the different type of parts, the filling level is detected by a light barrier

**Electro-valve:** 1 5/2-way valve, monostable, 24Vdc, with led and manual push button

**Sensors:** 1 light barrier  
2 micro switches  
1 magnetic “reed” sensor  
1 encoder (light fork)

**PLC wiring:** Digital inputs / outputs 5DI / 3DO

**Interface:** Interface box with SUB-D 25 pin connector

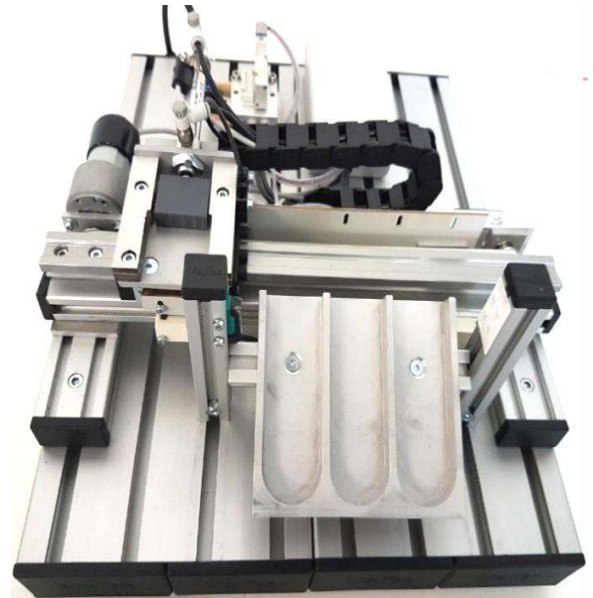

### Combinations

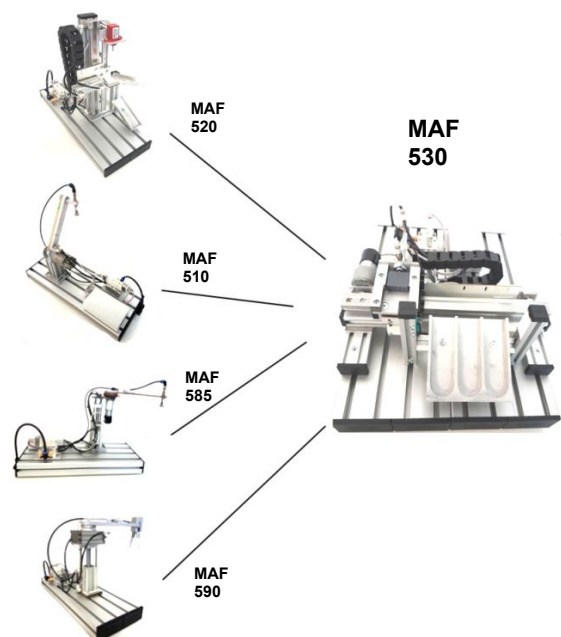

**MAF-535-SC**  
**CONVEYOR STATION**

Flexible Automation Module “Conveyor Station”, ready to work directly with a PLC, in the beginning individually (sorting process) and later combining it with other modules to carry out a manufacturing/automation process.

The parts move along a linear axis, coming from another station, the length of the conveyor is 650 mm.

The movement of the linear axis, which transport the workpiece, is carried out by a 24Vdc electric motor and the positioning by encoder (pulse counter). The speed of the motor can be controlled by hand with a potentiometer or by PLC with an analogous signal (0 – 10 V). On the way are two sensors (inductive and optical) for identification, and at the end of the conveyor there is a light barrier.

The station is mounted on an aluminium profile, measures 650 x 400 x 100 mm. Weight 3,5 kg

Training and learning:

Transport mechanics of the lineal axis, speed control, material detection, position detection and stopping techniques: pulse counting (light fork encoder) and PLC programming, interpretation of diagrams and schematics, fault location and repair, safety and emergency conditions, mechanical and electrical commissioning

**Technical data:**

- Construction:**
- \*Aluminium profile 650 x 400mm.
  - \*Lineal conveyor: Transport band with electric lineal axis and encoder
  - \*Connection interface
  - \*Relay control module: electric motor activation with speed control

**Actuators:** 1 electric lineal axis: servomotor with reduction, 24Vdc, positioning by encoder with 16 pulses per rotation, accuracy 6mm. Control box with speed regulation

- Sensors:**
- 1 one way light sensor
  - 1 capacitive sensor
  - 1 inductive sensor
  - 1 encoder (light fork)

**PLC wiring:** Digital inputs / outputs 4DI / 2DO  
Analog output: 1AO

**Interface:** Interface box with SUB-D 25 pin connector

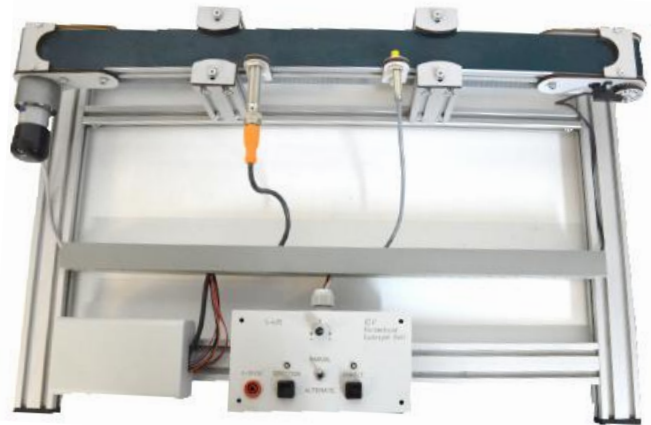

**Combinations**

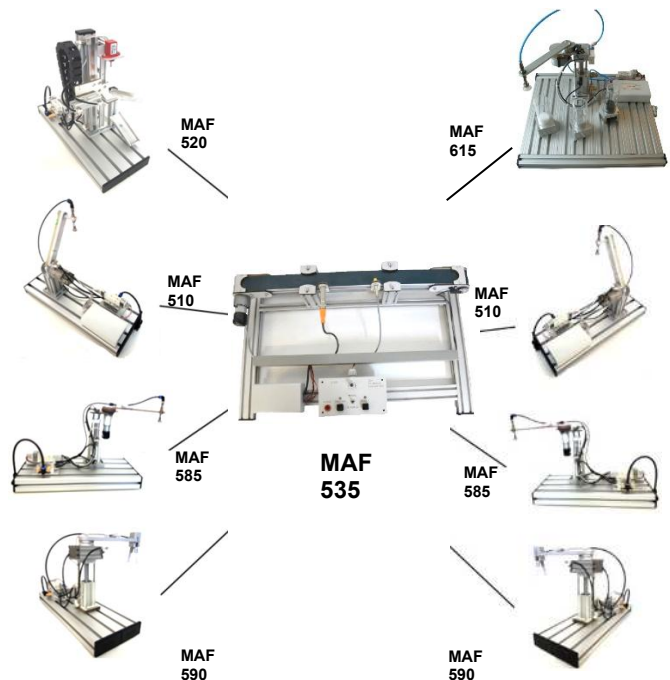

## MAF-570 ROTARY INDEX TABLE

Flexible Automation Module "Rotary Index Table", ready to work directly with a PLC, in the beginning individually (part detection and recognition) and later combining it with other modules to carry out a manufacturing/automation process.

An identification rotary table, with rotation by electric motor provided with 4 locations for pieces at 90°, detects and classifies the type of piece while it rotates. Workpieces must be deposited and picked up by other adjacent stations. A check unit mounted over the rotary index table with three sensors recognizes the workpieces when "present", "bright", "dark" and "metallic". The results can be displayed on the indication panel. The 90° positions are selected by an inductive sensor. The motor control is carried out with a relay.

The station is mounted on an aluminum base, measures 320 x 400 x 295 mm. Weight 4,8 kg

### Training and learning:

Mechanics of positioning of the rotary axis and adjustment of the sensors for the correct stop and the detection of the piece according to the configured distance. Recognition of the type of part by combining the different sensors (inductive, capacitive and optical). Activation of indicator signal and control of a drive. PLC programming, interpretation of diagrams and schematics, fault location and repair, safety and emergency conditions, mechanical, electrical and pneumatic commissioning

### **Technical data:**

- Construction:**
- \*F-subplate 320 x 400mm.
  - \*Connection interface
  - \*Relay control module: electric motor activation
  - \*Rotary table with 4 locations at 90° and electric drive
  - \*Mesa giratoria con 4 ubicaciones a 90° y accionamiento eléctrico
  - \*Checking unit: 3 sensors for discriminating the type of part (inductive, optical and capacitive)
  - \*Indicator panel, with 3 leds

**Actuator:** 1 geared electric motor of 24Vdc, for rotary table activation, with

positioning system by inductive detector and activation by 2 outputs to control relay module

**Indicator panel:**

3 Leds in identification panel

**Sensors:**

2 inductive sensors  
1 capacitive sensor  
1 optical sensor

**PLC wiring:**

Digital inputs / outputs 4DI / 5DO

**Interface:**

Interface box with SUB-D 25 pin connector

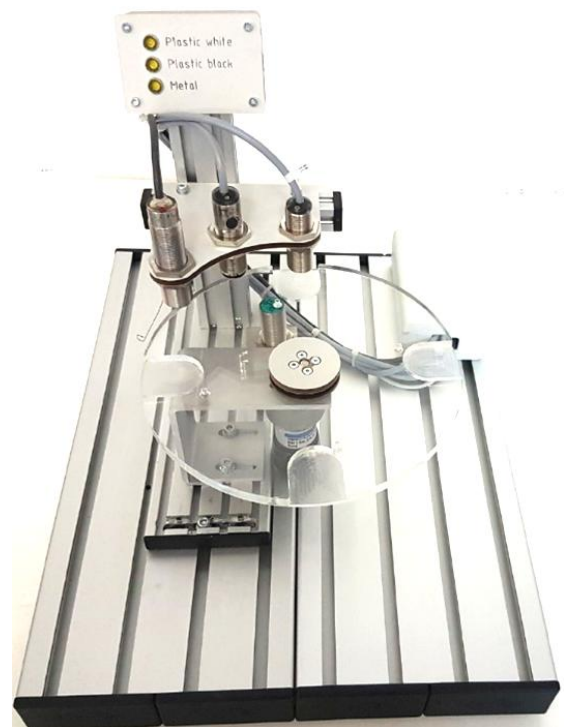

### **Combinations**

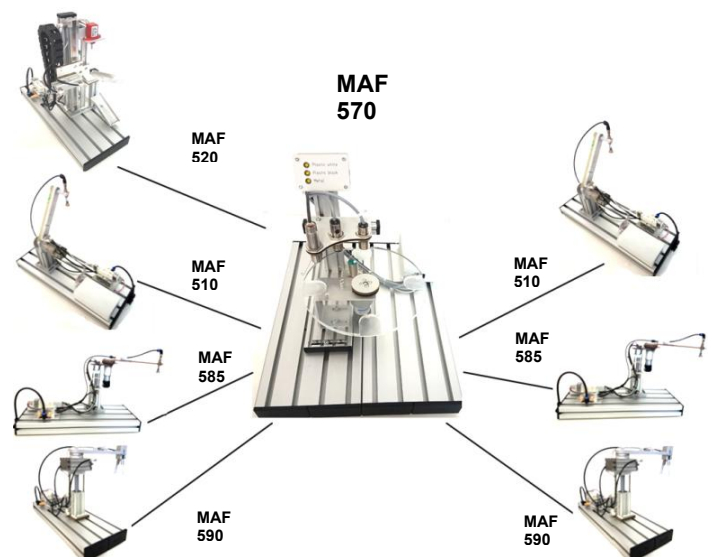

## MAF-585 PICK & PLACE ELECTRICALLY

Flexible Automation Module “Pick and Place Electrically”, ready to work directly with a PLC, in the beginning individually (pick and place technics) and later combining it with other modules to carry out a manufacturing/automation process

An electrically powered motor is lifted by a short-stroke cylinder. With a suction gripper, workpieces are picked up from another module at the first position and conveyed in a circle (0 - 375°) These workpieces can be placed at any position (i.e. every 5 °, implemented with a perforated disk and a fork light barrier: “encoder”). The end positions of the motor are secured and reported by two microswitches. At the end of the arm there is a suction cup for pick and place. The cylinder control as well as the activation of the vacuum takes place with two electromagnetic 5/2-way valves.

The station is mounted on an aluminum base, measures 160 x 400 x 230 mm. Weight 3 kg

### Training and learning:

Mechanics of positioning of the rotary arm and adjustment of the sensors for the correct stop. Motor control and positioning by pulse counting. Electro-pneumatic technologies, as well as cylinder position detection by reed detector and speed regulation, pick and place of working pieces by vacuum techniques, PLC programming, interpretation of diagrams and schematics, fault location and repair, safety and emergency conditions, mechanical, electrical and pneumatic commissioning

### Technical data:

- Construction:**
- \*F-subplate 160 x 400mm.
  - \*Connection interface
  - \*Relay control module: electric motor activation
  - \*Manifold valve unit
  - \*Electric swivel arm, with encoder and microswitches
  - \*Arm lift cylinder, with speed regulation by one way flow restrictors and reed detector.
  - \*Vacuum ejector / Suction cup

**Actuators:** 1 geared electric motor of 24Vdc, for swivel arm activation, with positioning system by encoder and

two micro-switches and activation by two outputs of control relay module.  
1 double effect cylinder with flow restrictors and reed detector.  
1 vacuum ejector with suction cup.

**Electro valves:** 2 5/2-way valves, monostable, 24Vdc, with led and manual push button, for cylinder control and vacuum ejector.

**Sensors:** 2 micro-switches  
1 reed sensor  
1 encoder with two channels

**PLC wiring:** Digital inputs / outputs 5DI / 4DO

**Interface:** Interface box with SUB-D 25 pin connector

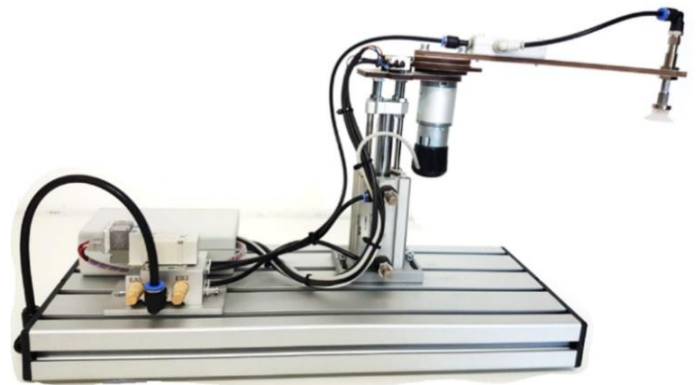

### Combinations

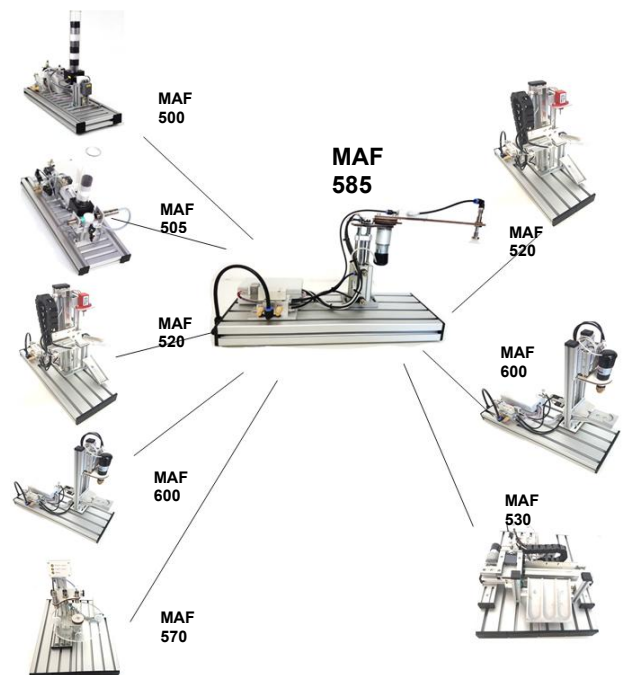

## MAF-590 PICK & PLACE PNEUMATICALLY

Flexible Automation Module “Pick and Place Pneumatically”, ready to work directly with a PLC, in the beginning individually (pick and place technics) and later combining it with other modules to carry out a manufacturing/automation process

A manipulator arm is lifted by a double-acting cylinder and rotates from 0 to 180° by a pneumatic rotary actuator. At the end of the arm there is an angular pneumatic clamp, with inductive clamp closing detector, to pick and place working-parts between adjacent stations. Stop positions and cylinder lift are defined by reed sensors. All the movements: rotation, elevation and opening-closing of the clamp are carried out by 5/2-way electromagnetic valves

The station is mounted on an aluminum base, measures 160 x 400 x 225 mm. Weight 3,5 kg

### Training and learning:

Mechanics of positioning of the rotary arm and adjustment of the sensors for the correct stop. Collection, turning and positioning of parts by electro-pneumatic techniques, double-acting cylinder and rotary actuator with speed adjustments by one way flow restrictions. Angular gripper with open/close detection. PLC programming, interpretation of diagrams and schematics, fault location and repair, safety and emergency conditions, mechanical, electrical and pneumatic commissioning.

### Technical data:

- Construction:**
- \*F-subplate 160 x 400mm.
  - \*Connection interface
  - \*Manifold valve unit
  - \*Arm lift cylinder, with speed regulation by one way flow restrictors and reed detector.
  - \*Swivel arm, pneumatic rotary actuator, with two reed sensors and speed regulation, with a clamp at the end
  - \*Pneumatic angular gripper with inductive sensor
- Actuators:** 1 double effect cylinder with two one-way flow restrictors and reed detector

1 pneumatic rotary actuator 0...180° with speed regulation and position detection by two reeds

1 angular gripper with open/close detection by inductive sensor

**Electro valves:** 2 5/2-way valves, monostable, 24Vdc, with led and manual push button, for cylinder control and vacuum ejector.

1 5/2-way valve, bistable, 24Vdc solenoids, leds and manual push buttons

**Sensors:** 1 inductive sensor  
3 “reed” sensors

**PLC wiring:** Digital inputs / outputs 4DI / 4DO

**Interface:** Interface box with SUB-D 25 pin connector

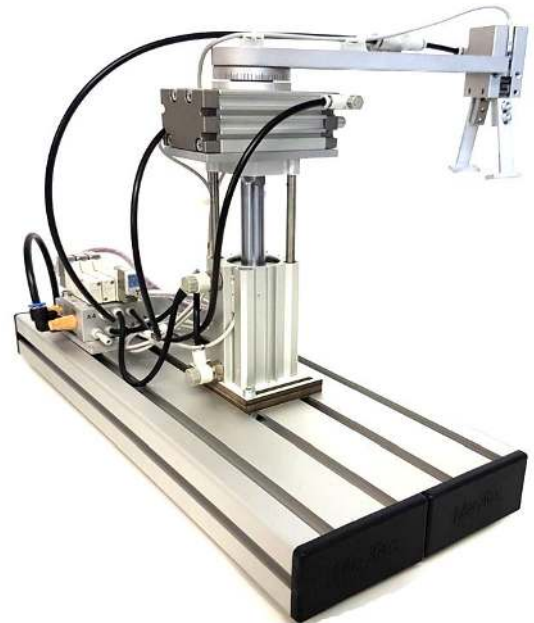

### Combinations

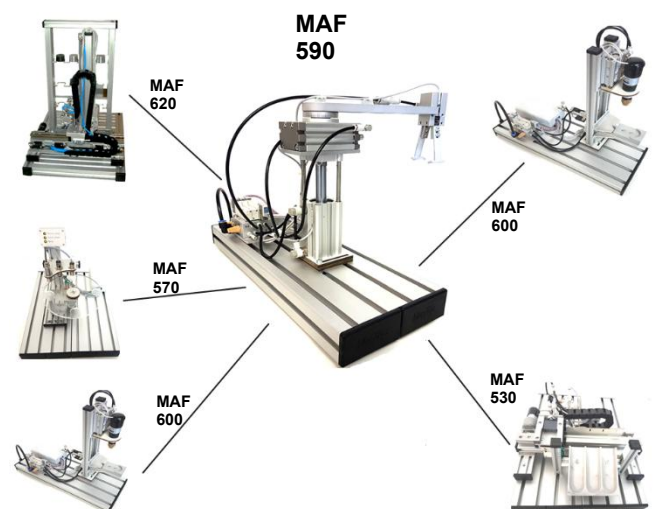

## MAF-600 WORKING DRILL

Flexible Automation Module “Working Drill”, ready to work directly with a PLC, in the beginning individually (pneumatics and drill motor activation) and later combining it with other modules to carry out a manufacturing/automation process

A drill is moved by a double-acting compact cylinder and simulates machining on the working part arranged on the piece tray by activating its electric motor through a contactor relay. The positions of both movements: drill and part tray, are defined by 4 reed detectors, located in the double-acting cylinders that carry out their movement.

The control of the elevation / descent of the drill, and of the positioning of the piece tray are carried out by 5/2 solenoid valves.

The station is mounted on an aluminum base, measures 160 x 400 x 225 mm. Weight 3,5 kg

### Training and learning:

Mechanics of the displacement of the drill and the piece tray and adjustment of the sensors for the correct stop. Electro-pneumatic technologies, as well as cylinder position detection by reed detector and speed regulation Electric motor control by relay module. PLC programming, interpretation of diagrams and schematics, fault location and repair, safety and emergency conditions, mechanical, electrical and pneumatic commissioning

### Technical data:

- Construction:**
- \*F-subplate 160 x 400mm.
  - \*Connection interface
  - \*Manifold valve unit
  - \*Relay control module: electric motor activation
  - \*Drill, electric Vdc motor
  - \*Vertical structure with double effect cylinder and drill
  - \*Lineal axis, double effect cylinder with piece tray

- Actuators:**
- 1 vertical axis, double effect cylinder with two “reeds” and two one-way flow restrictors for speed regulation

1 lineal axis, double effect cylinder with two “reeds” and two one-way flow restrictors for speed regulation

1 electric motor, drill, turn in both directions by two outputs

**Electro valves:** 1 5/2-way valve, monostable, 24Vdc, with led and manual push button.  
1 5/2-way valve, bistable, 24Vdc with leds and manual push buttons

**Sensors:** 4 “reed” magnetic sensors

**PLC wiring:** Digital inputs / outputs 4DI / 5DO

**Interface:** Interface box with SUB-D 25 pin connector



### Combinations

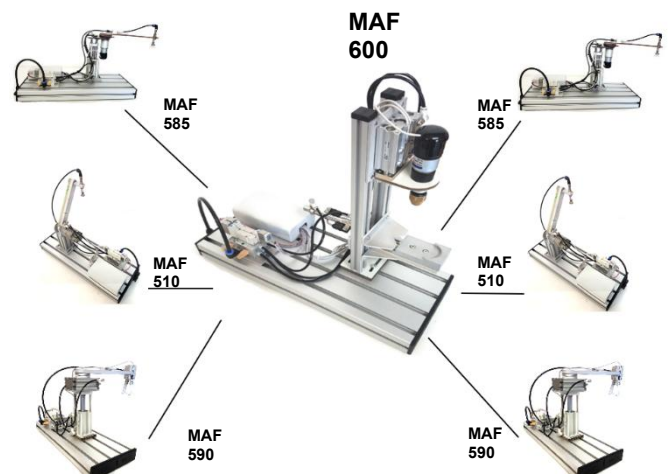

## MAF-615 STORAGE STATION

Flexible Automation Module “Storage Station”, ready to work directly with a PLC, in the beginning individually (pneumatics pick and place and electric motor activation- stop in storage positions) and later combining it with other modules to carry out a manufacturing/automation process

There are three vertical warehouses to house the types of parts, which are deposited by a manipulator arm with a suction cup and rotation driven by an electric motor. The arm is mounted on a compact double-acting cylinder, which raises/lowers, with a reed sensor for detection its position.

The rotation of the arm by geared motor and “light fork” encoder. From the initial position (defined by micro, to pick up another module) the working parts can be deposited in the range 0...375° (the positions are defined by the PLC program via encoder pulse counting, for example 5° per pulse). The control of the elevation / descent of the arm, and the suction of the part are carried out by monostable 5/2 solenoid valves and suction cup with vacuum ejector.

The station is mounted on an aluminum base, measures 360 x 400 x 225 mm. Weight 5 kg

### Training and learning:

Mechanics of positioning of the rotary arm and adjustment of the sensors for the correct stop. Motor control and positioning by pulse counting. Electro-pneumatic technologies, as well as cylinder position detection by reed detector and speed regulation, pick and place of working pieces by vacuum techniques, PLC programming, interpretation of diagrams and schematics, fault location and repair, safety and emergency conditions, mechanical, electrical and pneumatic commissioning

### Technical data:

**Construction:**

- \*F-subplate 360 x 400mm.
- \*Connection interface
- \*Manifold valve unit
- \*Relay control module: electric motor activation
- \*Swivel arm, electric gearmotor with encoder, microswitches and suction cup

\*Arm lift cylinder, with speed regulation by one-way flow restrictors and reed detector.

\*Vacuum ejector / Suction cup

\*3 vertical warehouses

**Actuators:**

- 1 vertical axis, double effect cylinder with two “reeds” and two one-way flow restrictors for speed regulation
- 1 vacuum ejector with suction cup
- 1 electric gearmotor with encoder

**Electro valves:** 2 5/2-way valve, monostable, 24Vdc, with led and manual push button.

**Sensors:**

- 1 “reed” magnetic sensor
- 2 micro switches

1 encoder with two channels

**PLC wirings:** Digital inputs / outputs 5DI / 4DO

**Interface:** Interface box with SUB-D 25 pin connector

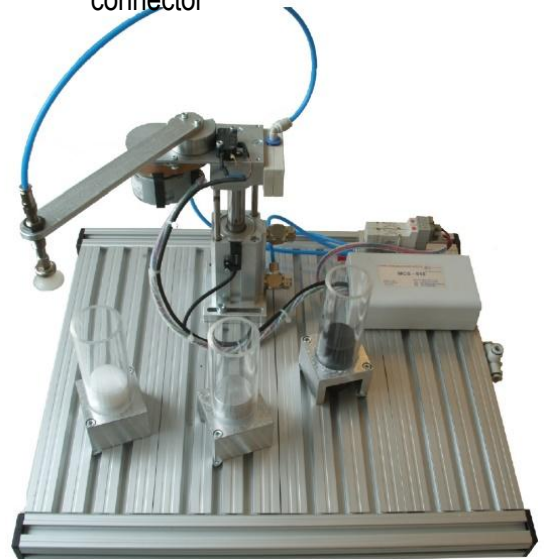

### Combinations

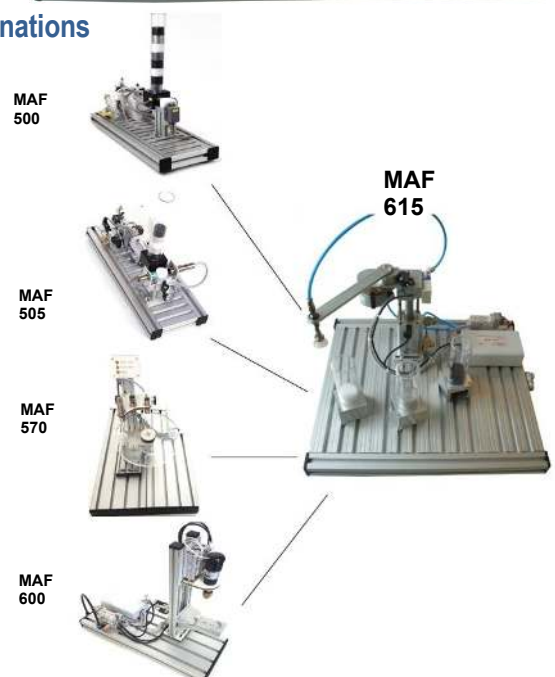

## MAF-620 HIGH RACK WAREHOUSE

Flexible Automation Module "High Rack Warehouse", ready to work directly with a PLC, in the beginning individually (classification / storage parts process) and later combining it with other modules to carry out a manufacturing/automation process

One electric linear unit with tooth belt drive and two pneumatic linear units take the workpiece from a warehouse position and bring it to a delivery position (or vice versa). The warehouse has 3 racks at different heights.

The ends of the horizontal electrical axis X are determined by two microswitches and those of the vertical axis Z by two detectors. Two encoders are available to position both axes. A reflex light barrier enables workpieces to be recognized in the storage container. The pneumatic Y-axis is controlled with reed sensors. Motor control by reversing contactor circuit. The control of cylinders, axes Z and Y, is carried out by solenoid valves.

The station is mounted on an aluminum base, measures 360 x 400 x 450 mm. Weight 6,5 kg

### Training and learning:

Mechanics of positioning and adjustment of the sensors (microswitches, reed, reflex...) for a correct positioning/detection of the part. Motor control and positioning by pulse counting. Electro-pneumatic technologies, as well as cylinder position detection by reed detector and speed regulation, PLC programming, interpretation of diagrams and schematics, fault location and repair, safety and emergency conditions, mechanical, electrical and pneumatic commissioning

### **Technical data:**

- Construction:**
- \*F-subplate 320 x 400mm.
  - \*Connection interface
  - \*Manifold valve unit
  - \*Relay control module: electric motor activation
  - \* Electric linear guide, horizontal X axis.
  - \*Pneumatic cylinder, Y axis
  - \*Pneumatic rodless vertical cylinder, Z axis.
  - \*Warehouse with 3 racks

- Actuators:**
- 1 electric lineal guide with two microswitches and encoder
  - 1 vertical rodless cylinder with two "reed", encoder and flow restrictions
  - 1 pneumatic cylinder with two reeds
- Electro valves:**
- 1 5/2-way valve, monostable, 24Vdc, with led and manual push button.
  - 1 5/3-way valve, 24Vdc solenoids, with leds and manual push buttons
- Sensors:**
- 4 "reed" magnetic sensor
  - 2 micro switches
  - 2 encoder with two channels each
  - 1 reflex light barrier sensor
- PLC wiring:** Digital inputs / outputs 11DI / 5DO
- Interface:** Interface box with SUB-D 25 pin connector



### **Combinations**

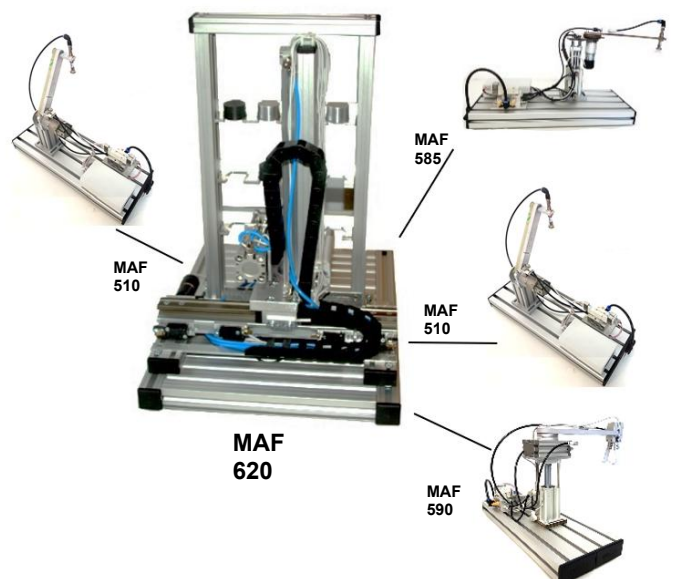

## MAF-630 ROBOTIC ARM - DOBOT

The DOBOT Magician Advanced is the arm robot desktop all rounder for countless applications., starting with handling, recording coordinates and positions, tracing trajectories, acquiring and positioning parts at first working individually to later combine it with the various MAF modules to perform an automation process

Thanks to its size and work area, it can be combined with MAF modules. It integrates an interface that allows it to be connected to any PLC, guaranteeing easy communication between the robot and the PLC.

The DOBOT Magician Advanced Communication contains DOBOT Studio - the professional and free software (for Windows and Mac) for controlling your DOBOT Magician. You can quickly program and save any position within its range using the teach and playback function. Here you program your robot arm intuitive and directly on the device. To do this, hold down a button on the head of the DOBOT Magician, guide the robot arm to the desired position and release it at the end point to be programmed

Thanks to its large number of communication modules, the DOBOT Magician Advanced Communication has every imaginable interface out of the box compared to its little brother, the DOBOT Magician Basic. In addition to control via WLAN and Bluetooth, a control pad (similar to a gamepad) and an intuitive app for iPhone and iPad are available. (free download from the App Store).

Whether as a 3D printer, for drawing or for pick and place applications. Thanks to the extensive range of accessories such as vacuum cups, grippers, pen holders, 3D printing sets and much more. the possible uses are extremely diverse. Not least thanks to the high quality optional

The station is mounted on an aluminum base, measures 320 x 400 x 450 mm. Weight 10 kg

### Training and learning:

Handling by means of a 4-axis robot arm, programming of coordinates, trajectories and speeds. Acquisition and positioning of pieces by means of a gripper / suction cup on a robot arm. Communication with PLC to work together with adjacent MAF modules. Combination of various technologies

(sensors, electro-pneumatics, mechanics, electricity...) programming, fault location and repair, safety conditions, emergency, etc..

### Technical data:

- Construction:**
- \*F-subplate 320 x 400mm.
  - \*Connection interface
  - \*Mini- compressor for gripper or suction cup
  - \*DOBOT Magician robotic arm

- Actuators:**
- 1 robotic arm, 4-Axis-Handling
  - 1 Suction cup / Gripper with mini-compressor

- PLC wirings:** Digital inputs / outputs 1DI / 1DO

- Interface:** Interface box with SUB-D 25 pin connector



### Combinations

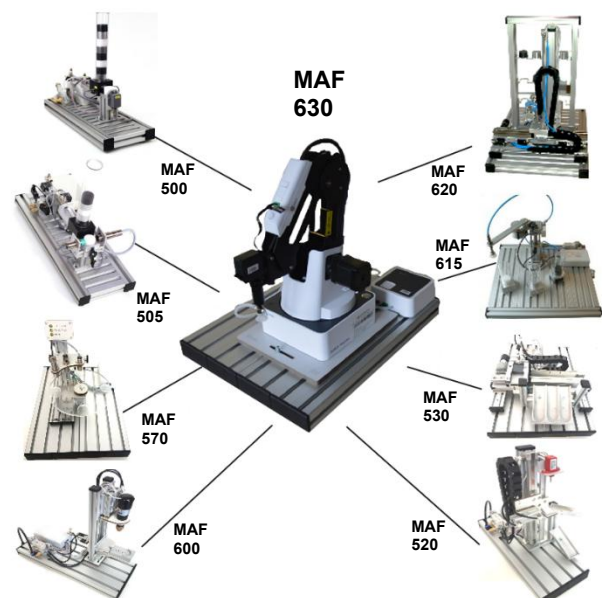

## DOBOT Magician Advanced

### Technical data

Dimension: 345 × 290 × 485 mm

Weight: 8 kg

Repeatability: ±0,2 mm

Max. load: 500g

Range, ratio: 320 mm

Speeds:

Joints 1, 2 y 3:  $V_{max} = 320^\circ/s$

Joint Axe 4 servo:  $V_{max} 480^\circ/s$

Power supply: 110-240VAC, 50/60Hz

Working temperature: -10 a 60 °C

Inputs / Outputs:

up to 17, as PWM, in/out, or analog input

Accessories:

3D printing set included, pen holder,  
pneumatic gripper, suction cup

### Delivery composition

- Robotic arm Dobot Magician
- Suction kit:  
Including: suction cups, vacuum pump and  
4<sup>th</sup> servo-axis
- Pneumatic gripper
- 3D printing set incl.:  
Extruder inc., heating nozzle, filament,  
conveyor line, masking tape and printing  
plate glass
- Writing and drawing module.

## MAF-640

### ROBOTIC ARM DOBOT + BLUETOOTH + WIFI + GAMEPAD

DOBOT Robot Arm Assembly similar to the MAF 630  
with Wireless communication accessories and  
Gamepad keypad

Includes:

- MAF-630
- Bluetooth module
- WiFi module
- Gamepad and USB module

The station is mounted on an aluminum base,  
measures 320 x 400 x 450 mm. Weight 10 kg

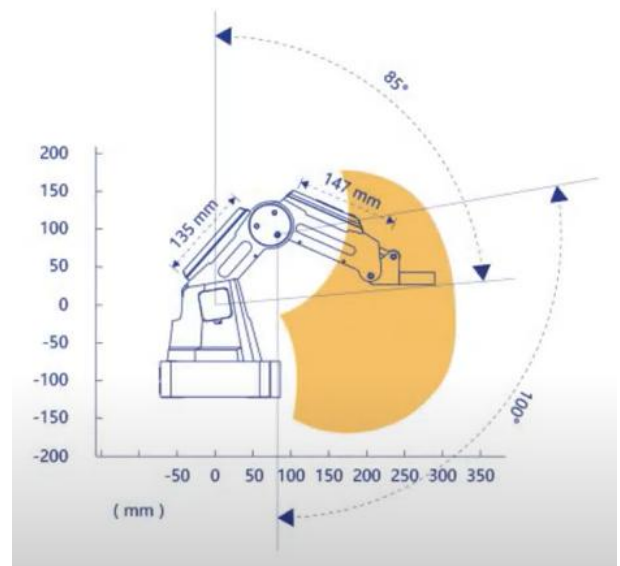
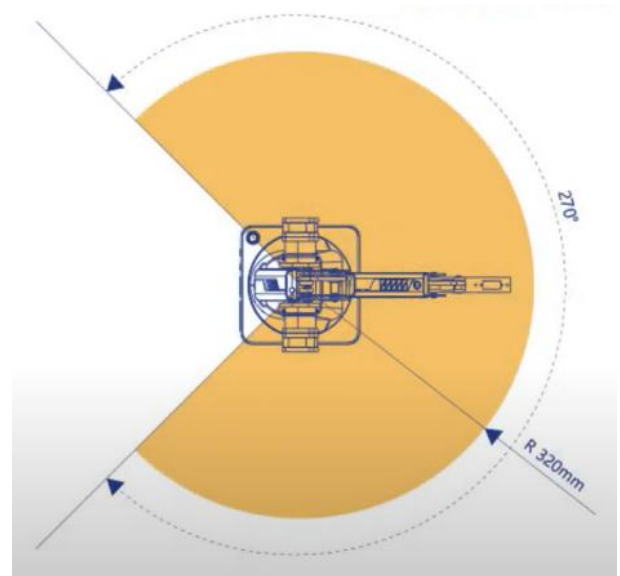

### Example combination MAF-620 – MAF-630/640

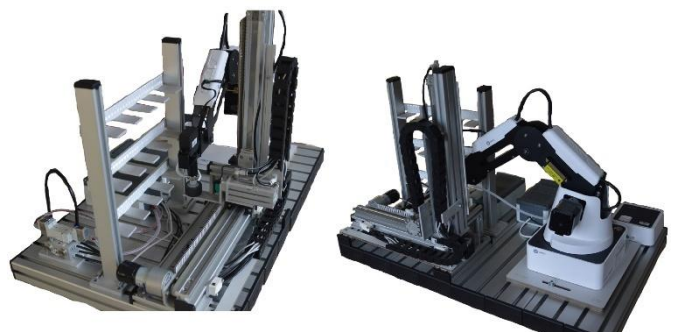

The images show how the DOBOT robot takes the  
part from the MAF-620 high rack warehouse

## MAF COMBINATIONS - "COMPACT SYSTEM MAF"

### MAF-690

Compact system **MAF -690**, made up by the two modules MAF 500 and MAF 615, FR maintenance unit, control panel and KIT of accessories and working parts

**MAF 540**  
FR unit

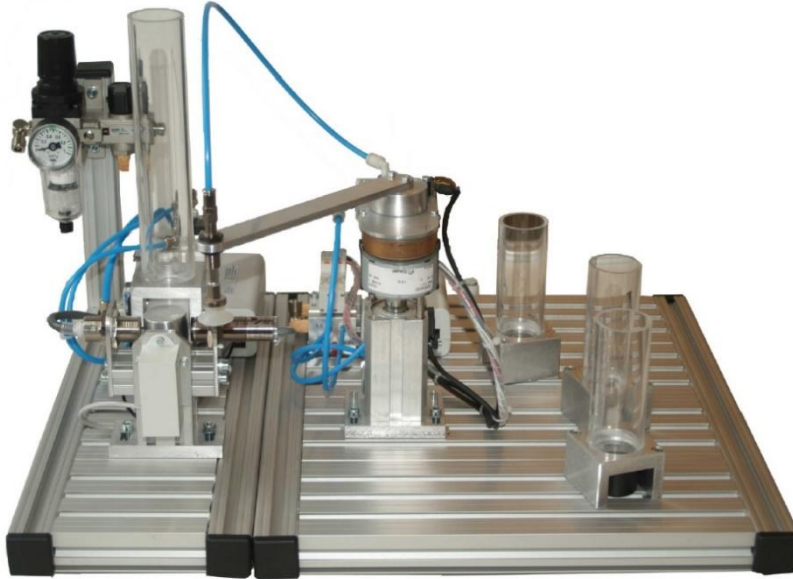

**MAF 500**  
Gravity feeder with part detection

**MAF 615**  
Storage station



**MAF 550**  
KIT of accessories and parts



**MAF 560**  
Control panel

*The system to work requires a PLC or other controls, not included. PLC's reference: MAF-690/1215C*

### MAF-700

Compact system **MAF -700**, made up by the 4 modules MAF, FR maintenance unit, control panel and KIT of accessories and working parts

**MAF 540**  
FR unit

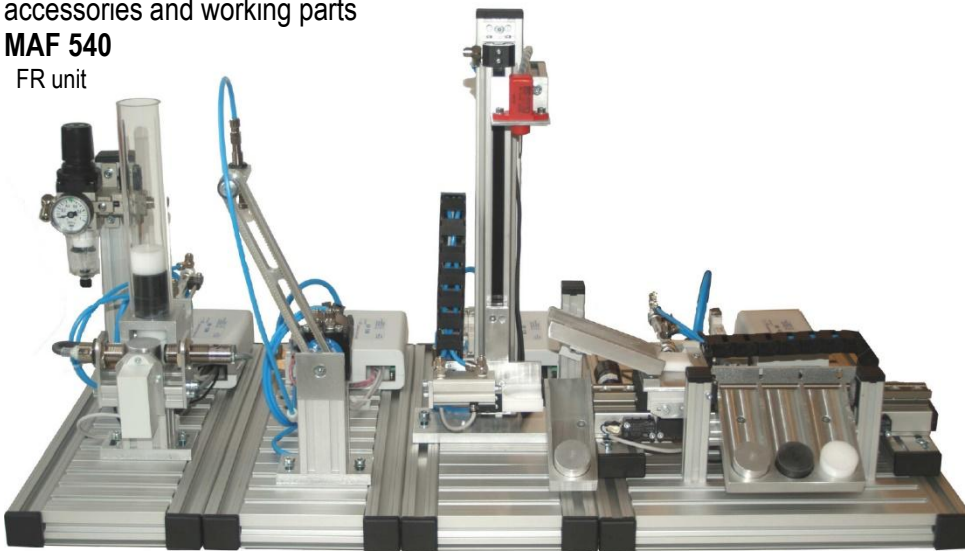

**MAF 500**  
Gravity feeder with part detection

**MAF 510**  
Swivel unit

**MAF 520**  
Analog meter

**MAF 530**  
Sorting station



**MAF 550**  
KIT of accessories and parts



**MAF 560**  
Control panel

*The system to work requires a PLC or other controls, not included. PLC's reference: MAF-700/1215C*

**Note:** If you require a PLC, please refer to the descriptions on page 22-23 and request the specific PLC reference indicated for the MAF combination, which will be adapted to the combination and will have connections via DB25

**MAF-710**

Compact system **MAF -710**, made up by the four modules MAF 500, MAF 510, MAF 535-SC and MAF-615, FR maintenance unit, control panel, KIT of accessories and working parts. PLC MAF-700/1215C optional

**MAF 540**  
FR unit

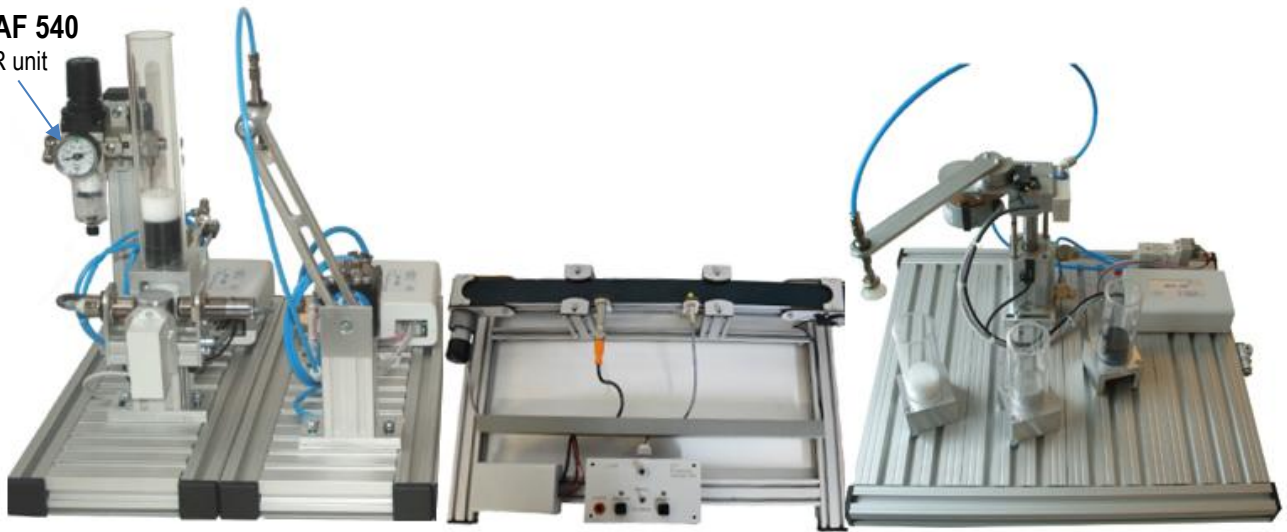

**MAF 500**  
Gravity feeder  
with part detection

**MAF 510**  
Swivel Unit

**MAF 535-SC**  
Convoyer

**MAF615**  
Storage station



**MAF 550** KIT of accessories and parts



**MAF 560** Control panel

*The system to work requires a PLC or other controls, not included. PLC's reference: MAF-700/1215C*

**Example: Siemens 1200 integrated into an aluminum frame.**

**MAF-700/1215C**

Siemens PLC for MAF-700/710 combination:

30 DI, 18 DO, 2 AI, 2 AO

See description in 22 page



**Note:** If you require a PLC, please refer to the descriptions on page 22-23 and request the specific PLC reference indicated for the MAF combination, which will be adapted to the combination and will have connections via DB25

## MAF-720

Compact system MAF -720, made up by the 3 modules MAF, FR maintenance unit, control panel and KIT of accessories and working parts

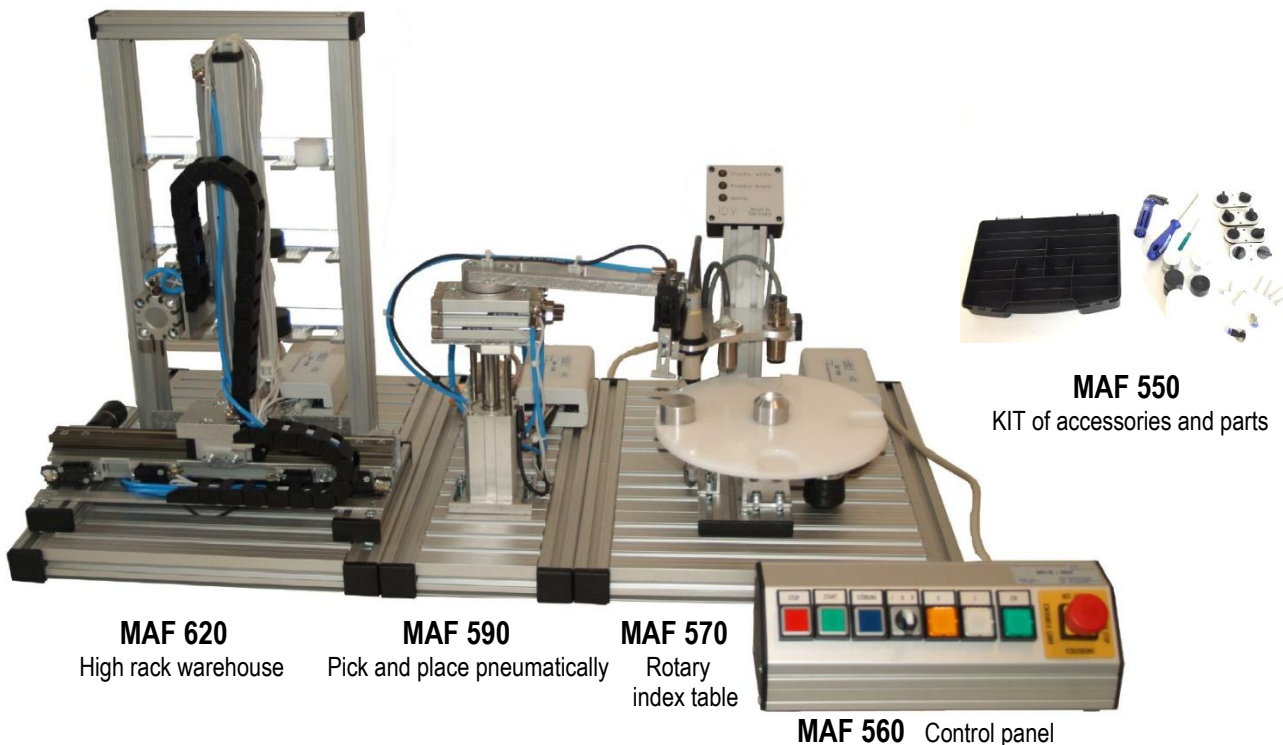

*The system to work requires a PLC or other controls, not included. PLC's reference: MAF-720/1215C*

## MAF-730

Compact system MAF -730, made up by the 6 modules MAF, FR maintenance unit, control panel and KIT of accessories and working parts.

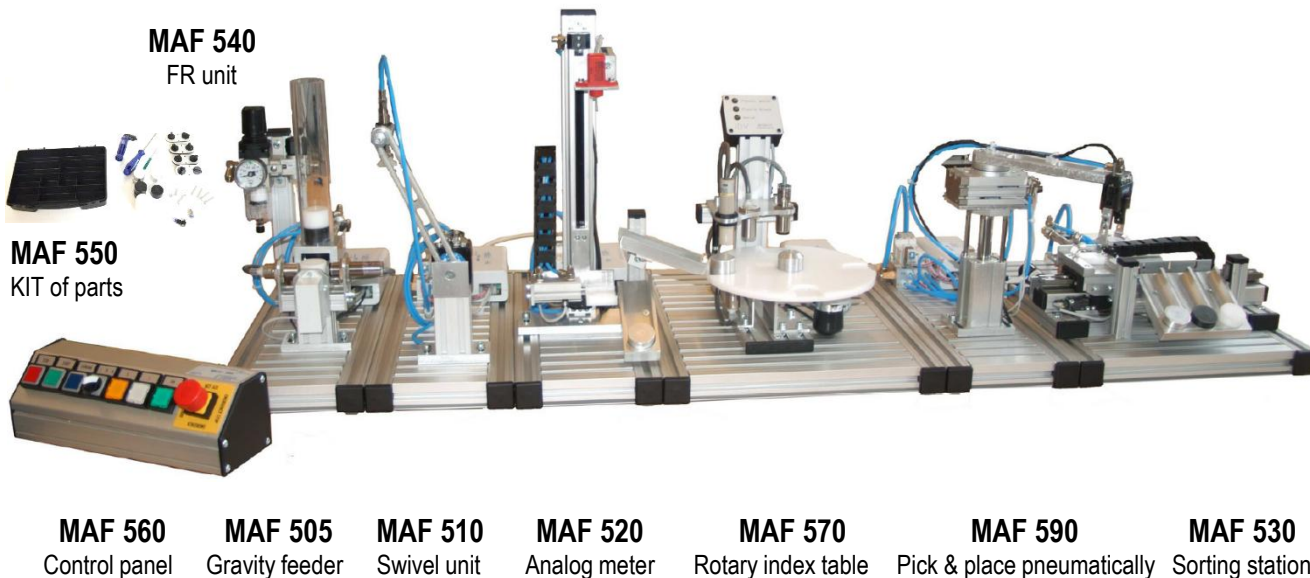

*The system to work requires a PLC or other controls, not included. PLC's reference: MAF-730/1215C*

**Note:** If you require a PLC, please refer to the descriptions on page 22-23 and request the specific PLC reference indicated for the MAF combination, which will be adapted to the combination and will have connections via DB25

**MAF-740**

Compact system MAF -740, made up by the 8 modules MAF, FR maintenance unit, control panel and KIT of accessories and working parts

**MAF 540**  
FR unit

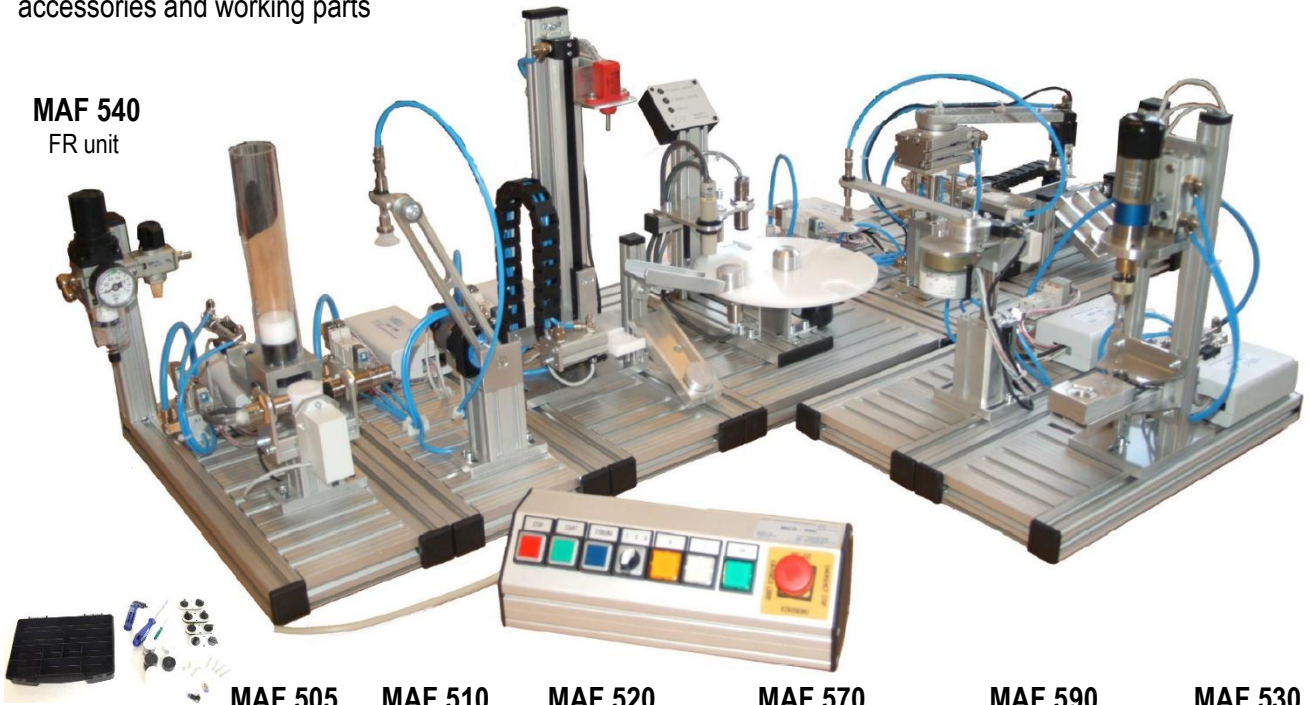

**MAF 505**  
Gravity feeder

**MAF 510**  
Swivel unit

**MAF 520**  
Analog meter

**MAF 570**  
Rotary index table

**MAF 590**  
Pick & place pneumatically

**MAF 530**  
Sorting station

**MAF 550**

Kit of accessories and parts

**MAF 560**

Control panel

**MAF 585**

Pick & place electrically

**MAF 600**

Working drill

*The system to work requires a PLC or other controls, not included. PLC's reference: MAF-740/1215C*

**MAF-760**

Compact system MAF -760, made up by the 9 modules MAF, FR maintenance unit, control panel and KIT of accessories and working parts

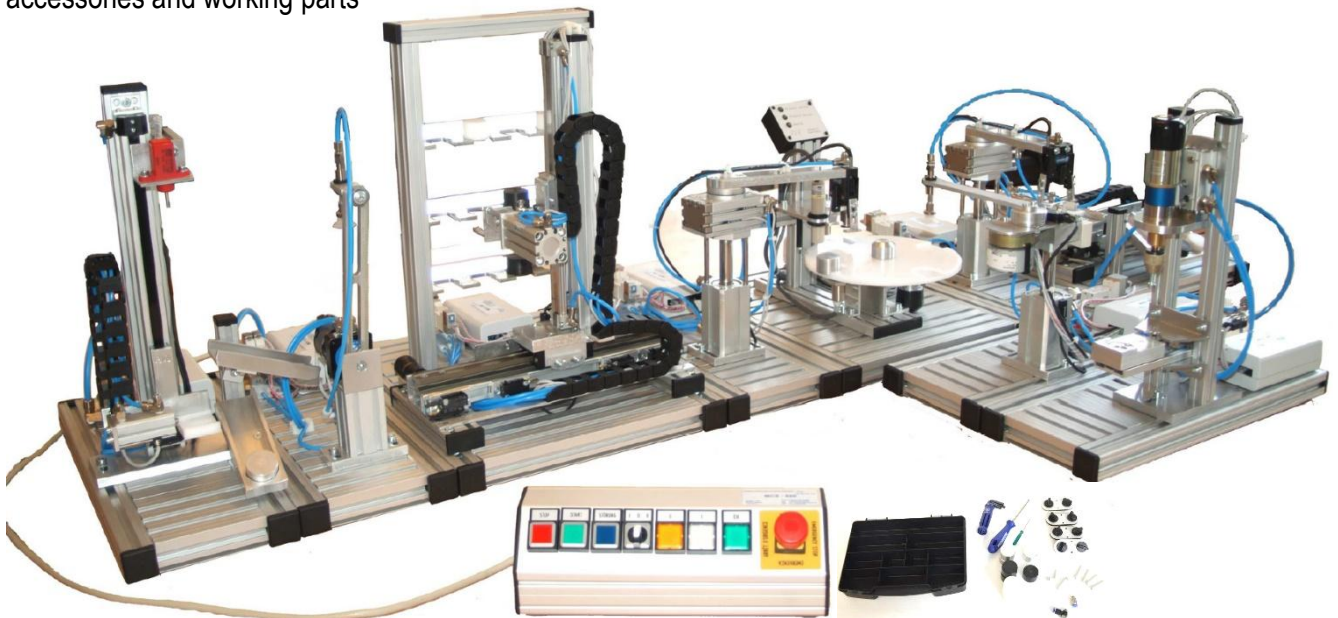

**MAF 520**  
Analog meter

**MAF 510**  
Swivel unit

**MAF 620**  
Warehouse

**MAF 590**  
Pick & Place pneum.

**MAF 570**  
Rotary index table

**MAF 590**  
Pick & Place pneum.

**MAF 530**  
Sorting

**MAF 560**  
Control panel

**MAF 550**  
Kit of parts

**MAF 585**  
Pick & Place electrically

**MAF 600**  
Working drill

*The system to work requires a PLC or other controls, not included. PLC's reference: MAF-760/1215C*

**Note:** If you require a PLC, please refer to the descriptions on page 22-23 and request the specific PLC reference indicated for the MAF combination, which will be adapted to the combination and will have connections via DB25

## ACCESSORIES & PLC'S

### MAF-540 FR UNIT

FR pneumatic maintenance unit, filter with semi-automatic water separator, pressure regulator with manometer, manual 3/2 port valve and quick connection fittings.

Filter body in polycarbonate

Adjustable and lockable pressure regulator, pressure range from 0,5 to 8 bar

3/2 valve for opening/closing with silencer

Fittings: tube inlet Ø 6 mm / tube outlet Ø 4 mm

FR unit mounted on vertical aluminum profile



MAF modules do not include the FR unit. When a Combined MAF System is available, only one FR unit is required. When you want to control individual modules, you will need one for each module or have a classroom enabled with a maintenance unit.

### MAF-569 SLAVE ADAPTER

Adapter for connection via SUB-D connector to the PLC of a slave-base with Ø 4 mm safety sockets. It allows you to easily connect external equipment such as valves, switches, sensors and relays from our electro-pneumatic and electro-hydraulic equipment to the PLC using Bus technology.

Connections:

11 sockets for inputs

8 sockets for outputs

2 sockets for power

1 emergency socket (24)

1 SUB-D25 female connector



### MAF-550 ACCESSORIES KIT / WORKING PARTS

A kit of accessories and work pieces is required to work with up to 4 MAF modules

Components:

- 1 Storing box
- 1 Screw driver, slotted
- 1 Screw driver, cross
- 1 Allen key set
- 4 Connectors to connect different MAF modules
- 1 angle reduce connector: Ø 6 - Ø 4mm
- 1 straight reduce connector: Ø 6 - Ø 4mm
- 1 straight connector: M5 - Ø 4 mm
- 2 angle connectors: M5 - Ø 4 mm
- 4 locking plug's: Ø 4 mm
- 9 workpieces, Ø30mm cylinders with different material and height:

Aluminium: 2 x H=20 mm, 1 x H=21 mm

Black plastic: 2 x H=20 mm, 1 x H=19 mm

White plastic: 3 x H=20 mm



## MAF-560 CONTROL PANEL

The control panel consist on a Alu-frame. To place on a surface or work table. The control panel is connected with a 1m cable on a 25 pin D-SUB plug.

- 1 NC push button with lamp included
- 3 NA push buttons with lamps included
- 1 / 2 position switch with interlock
- 2 Lamps
- 1 Emergency push button
- Weight 0.6 kg
- PLC wiring: Digital inputs/ outputs: 6DI / 5DO



## MAF-565 CONTROL PANEL WITH JOY SITCK

The control panel consist on a Alu-frame. To place on a surface or work table. The control panel is connected with a 1m cable on a 25 pin D-SUB plug.

- 1 NC push button with lamp included
- 3 NA push buttons with lamps included
- 1 / 2 position switch with interlock
- 2 Lamps
- 1 Emergency push button
- 1 Joystick for four positions, with 4 extra outputs
- Weight 0.8 kg
- PLC wiring: Digital inputs/ outputs: 6DI / 5DO  
Analog inputs: 4AI



## MAF-560/565-TP 400 HMI CONTROL PANEL

Siemens TP700 touchscreen integrated in an aluminum frame, with the same functions as standard panels in the HMI.

- 1 NC push button with lamp included
- 3 NA push buttons with lamps included
- 1 / 2 position switch with interlock
- 2 Lamps
- 1 Emergency push button
- 1 Joystick for four positions(only MAF-656-TP400)



**MAF-560-TP 400** Inputs/outputs: 6DI/5DO

**MAF-565-TP 400** Inputs/outputs: 6DI/5DO+4AI

## MAF-\_\_\_-SC SPEED CONTROLLER

Extra device to control the speed of the electric motors integrated in the MAF modules

It has two switch-selectable speed regulation modes:

- Manual regulation by potentiometer
  - Regulation by PLC control
- Introducing 0 to 10 Vdc from PLC

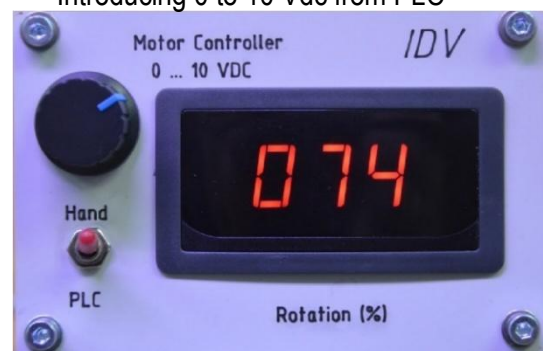

The MAF module to be requested in the order with the termination SC (SPEED CONTROLLER), to include the speed regulator.

Available with the following MAF modules:

- MAF-530-SC
- MAF-535-SC
- MAF-570-SC
- MAF-585-SC
- MAF-600-SC
- MAF-615-SC
- MAF-620-SC

Available in the following MAF combinations:

- MAF-690-SC (includes one SC regulator)
- MAF-700-SC (includes one SC regulator)
- MAF-710-SC (includes two SC regulators)
- MAF-720-SC (includes two SC regulators)
- MAF-730-SC (includes two SC regulators)
- MAF-740-SC (includes four SC regulators)
- MAF-760-SC (includes five SC regulators)

**Siemens PLC S7-1200  
SIMATIC S7-1215C-1PN**

PLC ready to work, mounted on a rack to place it on a table and directly connect the MAF module(s) through the integrated D25 interfaces. Includes power supply, 2 analog signal displays and additional sockets and micro-switches for external use, all connected to a Siemens PLC S7 – 1200 (CPU S7 – 1215C PN).



The image shows a PLC ready to work with the superior combination of MAF-760

For lower solutions: MAF-690, 700, 720, 730, 740 this equipment can also be used and in the future be ready in case it is extended to a more complete solution, or request a lower PLC configuration adjusted to the available MAF combination. Different configurations available for S7 PLC with CPU-1215C on rack are shown, listing the number of inputs and outputs for each MAF combination

**MAF-690/1215C**

Siemens PLC for MAF-690 combination:  
22 DI, 18 DO, 2 AI, 2 AO

**MAF-700/1215C**

Siemens PLC for MAF-700/710 combinations:  
30 DI, 18 DO, 2 AI, 2 AO



**MAF-720/1215C**

Siemens PLC for MAF-720 combination:  
30 DI, 26 DO, 2 AI, 2 AO

**MAF-730/1215C**

Siemens PLC for MAF-730 combination:  
34 DI, 26 DO, 2 AI, 2 AO

**MAF-740/1215C**

Siemens PLC for MAF-740 combination:  
46 DI, 42 DO, 2 AI, 2 AO

**MAF-760/1215C**

Siemens PLC for MAF-760 combination  
62 DI, 46 DO, 2 AI, 2 AO

Description:



It has 10 DB25 connectors for direct connection of 9 MAF Modules and 1 Control Panel, 2 displays for analog visualization, 4mm sockets for external connection, microswitches for input simulation and indicator LEDs

**PLC - S7-1200 (CPU 1215C PN):**

- 24VDC power supply
- 62 digital Inputs, 50 for the MAF combination, 12 free for external use with safety sockets and micro-switches for input simulation and indicator LEDs
- 46 digital outputs, 24 DC / 0.5 A, 41 for the MAF combination, 5 free for external use with safety sockets indicator LEDs
- 2 analog inputs, +-10 V, 11 Bit resolution, 1 for the MAF, 1 free with safety 4mm socket and connected to potentiometer for simulation
- 2 analog outputs, +-20 mA, 11 Bit resolution, on safety sockets with display for current/volts
- Execution time :80 ns (bit), 170 ns (word)
- Integrated High-Speed-Counter, up to 100 KHz
- Word operations, addition's .....
- Program memory 125 KByte, Data 1 MByte
- 16KByte Marker, all useable as holding marker adj
- 2048 Timer, all remanent adjustable 10ms till 9990s
- 2048 Counter, all remanent adjustable
- Ethernet-connection
- Programmable with PC-Software (TIA PORTAL) and STEP 7 Basic (included)
- Integrated digital and analog simulator
- On aluminum frame with 10 SUB-D connectors for the MAF-760. Allows external use through connection by available 4 mm sockets, with laboratory cables and 24 VDC power supply

## Siemens PLC S7-1500 SIMATIC S7-1512C-1PN

PLC ready to work, mounted on a rack to place it on a table and directly connect the MAF module(s) through the integrated D25 interfaces. Includes power supply, 2 analog signal displays and additional sockets and micro-switches for external use, all connected to a Siemens PLC S7 – 1500 (CPU S7 – 1512C).



The image shows a PLC ready to work with the superior combination of MAF-760

For lower solutions: MAF-690, 700, 720, 730, 740 this equipment can also be used and in the future be ready in case it is extended to a more complete solution, or request a lower PLC configuration adjusted to the available MAF combination.

Different configurations available for S7 PLC with CPU-1512C 1PN on rack are shown, listing the number of inputs and outputs for each MAF combination

### MAF-730/1512C

Siemens PLC for MAF-730 combination:  
32 DI, 32 DO, 5 AI, 2 AO

### MAF-740/1512C

Siemens PLC for MAF-740 combination:  
48 DI, 48 DO, 5 AI, 2 AO

### MAF-760/1512C

Siemens PLC for MAF-760 combination:  
64 DI, 48 DO, 5 AI, 2 AO

Mounted on a frame, as shown in the photo, with 10 DB25 connectors for direct connection of 9 MAF Modules and 1 Control Panel, 2 displays for analog visualization, 4mm sockets for external connection, microswitches for input simulation and indicator LEDs

### PLC - S7-1500 (CPU 1516-3 PN/DP):

- 24VDC power supply
- 64 digital Inputs, 50 for the MAF combination, 14 free for external use with safety sockets and micro-switches for input simulation and indicator LEDs
- 48 digital outputs, 24 DC / 0.5 A, 41 for the MAF combination, 7 free for external use with safety sockets indicator LEDs
- 4 analog inputs, +-10 V, 16 Bit resolution, 1 for the MAF, 3 free with safety 4mm socket and one connected to potentiometer for simulation
- 4 analog outputs, +-20 mA, 16 Bit resolution, on safety sockets with display for current/volts
- Execution time:48 ns (bit operation), 58 ns (word operation)
- Integrated High-Speed-Counter, up to 100 KHz
- Word operations, addition's .....
- Program memory 125 KByte, Data 1 MByte
- 16KByte Marker, all useable as holding marker adj
- 2048 Timer, all remanent adjustable10ms till 9990s
- 2048 Counter, all remanent adjustable
- Ethernet-connection
- Programmable with PC-Software (TIA PORTAL) and STEP 7 Basic (included)
- Integrated digital and analog simulator
- On aluminum frame with 10 SUB-D connectors for the MAF-760

Allows external use through connection by available 4 mm sockets, with laboratory cables and 24 VDC power supply

## Workstation LC2030

**Workstation LC2030** for open- and closed-loop control: Storage tank for use in training of binary control engineering and Level, Flow, Temperature and Pressure Control.

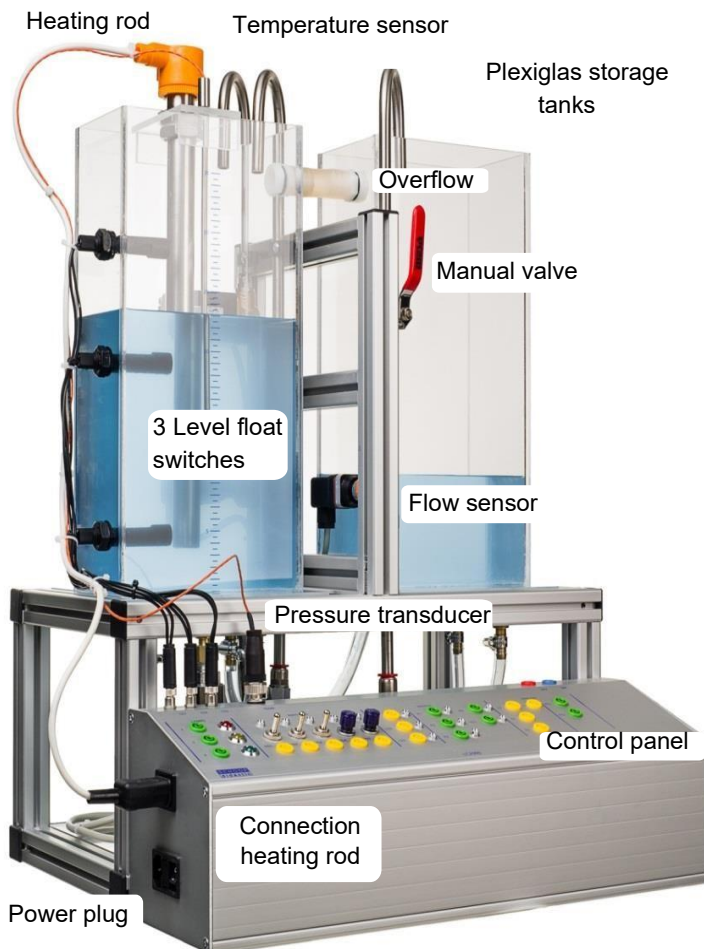

### Components LC2030

- 1x Rack for control panel,
- 2x Plexiglas storage tanks, 110 x 200 x 400 (D x W x H [mm]), capacity approx. 8 L,
- 2x Radial pump, max. flow rate 270 l/h
- 2x Valve for manual flow rate adjustment
- 3x Level float switch,
- 6x Quick-release connector, for automatic closing for pump connection,
- 1x Quick-release connector with drainage hose to empty tanks,
- 1x Operation LED (green),
- 1x Signal LED (yellow),
- 1x Error LED (red),
- 3x Operation switch,
- 2x Push-button switch.
- 1x Centrifugal pump with adjustable flow rate, max. 230 L/h (substitutes one radial pump),
- 1x Frequency converter for pump control,
- 1x Process pressure transducer for level measurement.

Dimensions: 520 x 720 x 450 (DxWxH [mm]),  
Weight: app. 26.00 kg

The workstation LC2030 has been designed for use in control engineering.

Six closed-control circuits are available: level control with controllable pump, flow control with controllable pump, pressure control with controllable pump, level control with controllable valve, flow control with controllable valve and temperature control.

Three pumps, three switches for float control, three buttons, two push-buttons and three lamps (red, yellow, green) are available for control purposes. Buttons at the control panel can be used for tasks such as emergency stop, process start and stop, interruption etc. Message lamps allow the identification of errors, faults and process conditions. By the colors of the lamps also traffic light circuits can be implemented.

On the panel all signals are available as standard signals 0 (2) -10V for analogue or 24V for binary signals via laboratory sockets (4mm), so that the workstation can be connected to each control unit (PLC, industrial controller, etc.).

### Optional extensions for LC2030

Closed Loop Level Control via Inflow Rate

- 1x Control Valve with control unit (0-10V).

Closed Loop Control, Flow Control with Control Valve

- 1x Flow meter (0-10V).

Closed Loop Flow Control with Centrifugal Pump

- 1x Flow meter (0-10V),
- 1x Valve for manual flow rate manipulation.

Closed-Loop Temperature Control

- 1x Temperature probe, PT100 with signal (0-10V)
- 1x Heating rod,
- 1x Circulation pump.

Cooler for temperature control

- 1x Cooler,
- 2x Ventilators.

Closed-loop pressure control

- 1x Pressure sensor (0-10V),
- 1x Valve for manual flow rate manipulation,
- 1x Manual manometer.

# Software LC2030 Training

## LC2030 Training

With the LC2030-Training, tasks from the field of open-loop and closed-loop control technology can be edited. The LC2030-Training allows you to work with the real workstation LC2030 or with an integrated simulation of the workstation.

In closed-loop control level, flow, pressure and temperature control are available. The systems can be controlled with standard controllers P, I, PI, PID and two-point controller. All control parameters may be chosen freely.

All signals are graphically monitored via trend displays. The integrated measured value acquisition records the signals and provides comprehensive evaluation options.

It is also possible to create open-controls using GRAFCET- or Logic-plans for different exercises. The control can be tested online with the real station or the integrated simulated training station and the flow of the plans can be monitored graphically. The connection between PC and workstation LC2030 is via I/O-Box 4488.

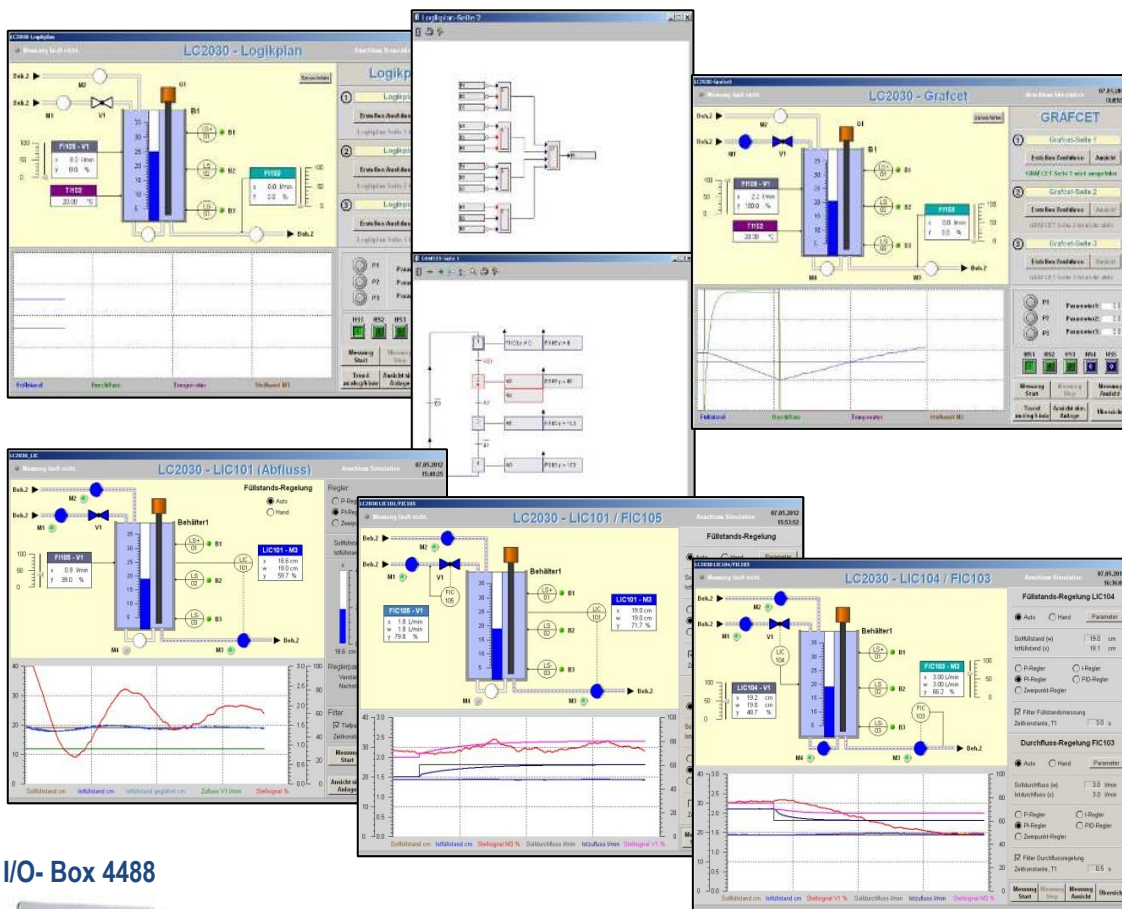

### I/O- Box 4488



Connecting real training unit LC2030 to PC with the interface I/O- Board 4488  
PC connection by ethernet connector and to the real training unit LC2030 by 4mm laboratory plugs

### WinErs Laboratory Version

The WinErs laboratory version is a development software for the realisation of automation Controls are created graphically with block structures, logic diagrams or GRAFCET plans

Personal operation surfaces can be created with the process visualization.

The WinErs laboratory version is connected to the workstation via I/O-Box

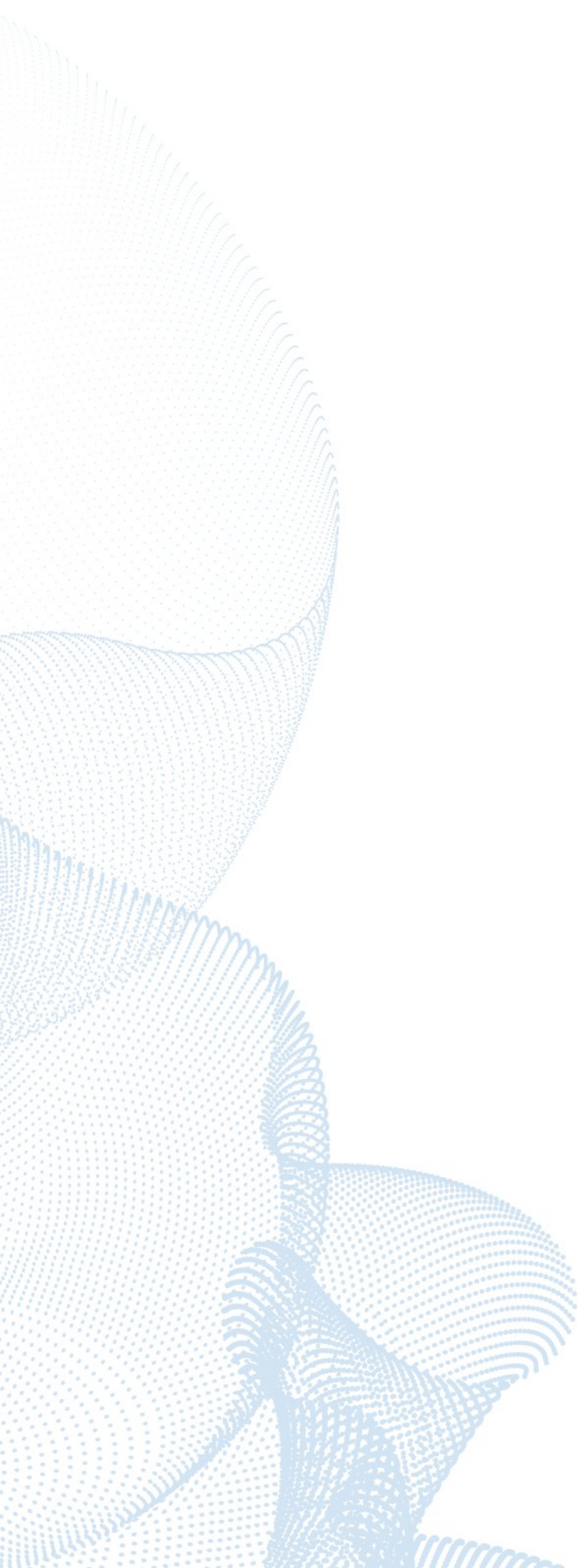

**HRE**  
**40 Years**

Pol. Ibaitearte 21  
20870 Elgoibar, Gip.

(+34) 943 74 21 30  
hre@hre.es

[www.hre.es](http://www.hre.es)