

# Fittings and accessories for lubrication systems

Product catalogue 2023



## Navigation

Solderless pipe union with tapered sleeve . . . . . 10

Solderless pipe union with cutting sleeve . . . . . 38

Adapters, plugs and washers . . . . . 70

Quick connectors . . . . . 82

Manifolds . . . . . 98

Tubes and hoses . . . . . 100

Fixing material . . . . . 116

Couplings . . . . . 122

Valves . . . . . 126

Pressure gauges ..... 134

Reservoirs and trays ..... 138

Lubricating nipples ..... 142

Filters ..... 146

Brushes ..... 150

Tools ..... 152

Manual grease guns ..... 163

Refill pumps ..... 166

## Table of contents

<b>Electronic part library</b> . . . . .	<b>8</b>	<b>Double-edged cutting sleeve union (DECS)</b> . . . . .	<b>40</b>
<b>Lubricants suitable for lubrication systems</b> . . . . .	<b>9</b>	Double-edged cutting sleeves D acc. to DIN 3861/ISO 8434-1 . . . . .	41
<b>Tapered sleeve fittings acc. to DIN 3854/DIN 3862</b> . . . . .	<b>10</b>	Union nuts M acc. to DIN 3861/ISO 8434-1 . . . . .	42
Provision of counterbore . . . . .	12	Straight screw-in connectors GE with metrical thread . . . . .	43
Form counterbores . . . . .	14	Straight screw-in connectors GE with Whitworth pipe thread . . . . .	44
Double-tapered sleeves for metal pipes . . . . .	14	Straight screw-in connectors GE with Whitworth pipe thread, made from stainless steel or brass . . . . .	45
Socket unions for metal pipes acc. to DIN 3871 . . . . .	15	Straight screw-in connectors GE with NPT pipe thread . . . . .	45
Reinforcing sockets for plastic tubes . . . . .	15	Straight screw-in glands XGE . . . . .	46
Tapered sleeves for plastic tubes acc. to DIN 3862 . . . . .	16	Straight tube-to-tube connectors G . . . . .	46
Connectors with tapered thread . . . . .	17	Straight tube-to-tube reducing connectors GR . . . . .	47
Connectors with cylindrical thread acc. to DIN 71428 . . . . .	18	Union studs GZ . . . . .	48
Bracketed connectors . . . . .	20	Straight tube studs EGE . . . . .	48
Tube-to-tube connector with air vent acc. to DIN 3862 . . . . .	21	T-connectors T . . . . .	49
T-connectors acc. to DIN 71433 . . . . .	22	Reducing T-connectors TR . . . . .	49
Bulkhead connectors with tapered thread . . . . .	24	Elbow connectors W . . . . .	50
Tube-to-tube connectors . . . . .	24	Elbow screw-in connectors WE with metrical thread . . . . .	50
Straight bulkhead fittings acc. to DIN 71429 . . . . .	25	Elbow screw-in connectors WE with Whitworth pipe thread . . . . .	51
Reducing piece . . . . .	25	K-connectors K . . . . .	52
Threaded sockets . . . . .	26	Female connector straight GAI with metrical thread . . . . .	53
Elbow bulkhead fittings acc. to DIN 71429 . . . . .	28	Female connector straight GAI with Whitworth pipe thread . . . . .	53
Elbows with cylindrical thread acc. to DIN 71433 . . . . .	28	Check valves GERV . . . . .	54
Elbows with tapered thread acc. to DIN 71429 . . . . .	29	Straight bulkhead connectors SV . . . . .	56
Elbows with tube end for pipe union for installation in counterbores acc. to DIN 3854/DIN 3862 . . . . .	30	Elbow bulkhead connectors WSV . . . . .	56
Banjo fittings acc. to DIN 71430 Form A . . . . .	31	Banjo fittings SWVE with metrical thread . . . . .	57
Banjo fittings acc. to DIN 71430 Form B . . . . .	32	Banjo fittings SWVE with Whitworth pipe thread . . . . .	57
Banjo fittings acc. to DIN 71430 Form C . . . . .	33	Banjo fittings WHK (high-pressure) with metrical thread . . . . .	58
Banjo fittings acc. to DIN 71430 Form D . . . . .	33	Banjo fittings WH and WHK (high-pressure) with Whitworth pipe thread . . . . .	58
Banjo fittings, rotatable . . . . .	34	Reducing connectors RED with cylindrical thread . . . . .	59
Banjo fitting with indicator pin for lubricant distributor . . . . .	34	Reducing connectors KOR with cylindrical thread . . . . .	59
Rotating joints . . . . .	35		
Cross joints . . . . .	36		
<b>High-pressure cutting sleeve unions acc. to ISO 8334-1</b> . . . . .	<b>38</b>		
Overview of fitting types . . . . .	39		

Connectors for pressure gauges MAV . . . . .	60	Reducing connectors RI with cylindrical thread for operating pressures up to 400 bar . . . . .	76
Connectors for pressure gauges MAVE . . . . .	60	Banjo fittings, rotatable . . . . .	77
L-connectors EL directionally adjustable . . . . .	61	Vent plugs with profile seal acc. to ISO 9974-2 . . . . .	79
L-connectors EVL directionally adjustable . . . . .	61	Vent plugs sealed by flat washer acc. to DIN 7603 . . . . .	79
Screw-in T-connectors TE, TH with metrical pipe thread . . . . .	62	Screw plugs VSTI . . . . .	80
Screw-in T-connectors TE, TH with Whitworth pipe thread . . . . .	62	Screw plugs sealed by flat washer acc. to DIN 7603 . . . . .	80
Swivel nut branch ET . . . . .	63	Flat washers . . . . .	81
Swivel nut elbow EW . . . . .	63	<b>Quick connectors . . . . .</b>	<b>82</b>
Swivels DVWE . . . . .	64	<b>Single-seal quick connectors . . . . .</b>	<b>85</b>
Swivels DG . . . . .	64	Straight screw-in connectors . . . . .	85
Blanking plug for cones BUZ . . . . .	65	Straight screw-in connectors with FKM threaded seal . . . . .	85
<b>Soft-seal cutting sleeve union (SSCS) . . . . .</b>	<b>66</b>	Adapters with tapered thread . . . . .	86
Straight screw-in connectors GE . . . . .	67	Banjo fittings with tapered thread . . . . .	86
Cone plugs VKA . . . . .	67	Elbows with tapered thread . . . . .	87
Straight screw-in connectors with shortened thread and function nut GE (short) . . . . .	68	Banjo fittings with O-ring threaded seal . . . . .	87
Straight bulkhead connectors with function nut SVZ . . . . .	68	Banjo fittings with FKM threaded seal . . . . .	88
Straight connectors (tube to tube) with function nut GZ . . . . .	69	Banjo fittings with hexagon socket and O-ring threaded seal . . . . .	88
T-connectors with function nut TZ . . . . .	69	Screw-in T-connectors . . . . .	89
<b>Adapters, plugs and washers . . . . .</b>	<b>70</b>	T-connectors . . . . .	90
Reducing connectors with cylindrical thread for operating pressures up to 45 bar (sealed by flat washer acc. to DIN 7603) . . . . .	72	Straight bulkhead connectors . . . . .	90
Reducing connectors with tapered thread for operating pressures up to 45 bar . . . . .	72	Tube-to-tube connector . . . . .	91
Reducing connectors with cylindrical thread for operating pressures up to 45 bar (sealed by flat washer acc. to DIN 7603) . . . . .	73	<b>Triple-seal quick connectors . . . . .</b>	<b>92</b>
Adapter for pressure gauges for operating pressures up to 45 bar (sealed by flat washer acc. to DIN 7603) . . . . .	73	Straight screw-in connectors with cylindrical thread . . . . .	93
Adapter for pressure gauges with cylindrical thread for operating pressures up to 45 bar . . . . .	74	Straight screw-in connectors with tapered thread . . . . .	93
Reducing connectors with tapered thread for operating pressures up to 350 bar . . . . .	74	Tube-to-tube connectors . . . . .	94
Elbow reducing connectors 45° with tapered thread for operating pressures up to 350 bar . . . . .	75	Banjo fittings with banjo bolt and cylindrical thread . . . . .	94
Elbow reducing connectors 90° with tapered thread for operating pressures up to 350 bar . . . . .	75	Elbows with tapered thread . . . . .	95
		Banjo fittings with cylindrical thread . . . . .	96
		Banjo fittings with tapered thread . . . . .	97
		Locking pin . . . . .	97

<b>Manifolds</b> . . . . .	<b>98</b>	<b>Couplings</b> . . . . .	<b>122</b>
Metering device manifolds . . . . .	99	Low-pressure quick-disconnect couplings . . . . .	123
<b>Tubes and hoses</b> . . . . .	<b>100</b>	Medium- and high-pressure quick-disconnect couplings . . . . .	123
Plastic tubing . . . . .	102	High-pressure couplings . . . . .	124
Tube and hose protections . . . . .	103	Couplings with return flow port . . . . .	125
Steel tubing . . . . .	104	<b>Valves</b> . . . . .	<b>126</b>
Stainless steel tubing . . . . .	105	Relief valve . . . . .	127
Low-pressure hoses		Relief valves with bleed valve	
for main lines max. 45 bar		and safety valve . . . . .	127
with pipe stud on both ends . . . . .	106	Pressure regulating valves, adjustable	
Low-pressure hoses for main lines max. 45 bar with tapered		(poppet valve) . . . . .	128
sleeve and socket union on both ends . . . . .	107	Adapters for valves . . . . .	128
Low-pressure hoses for main lines max. 45 bar with pipe stud on		Pressure regulating valves,	
both ends and with claw groove for		fixed pressure . . . . .	129
quick connectors . . . . .	108	Pressure relief/regulating valves for flow rates	
Low-pressure hoses		from 0.5–2 l/min . . . . .	131
for secondary lines max. 15 bar		Shut-off valves . . . . .	131
with pipe stud on both ends . . . . .	109	Solenoid valves . . . . .	133
Low-pressure hoses		<b>Pressure gauges</b> . . . . .	<b>134</b>
for secondary lines max. 15 bar		Standard pressure gauges . . . . .	135
with tapered sleeve and socket union on both ends . . . . .	109	Pressure gauges	
Low-pressure hoses for secondary lines max. 15 bar with pipe		with metrical thread . . . . .	135
stud on both ends and claw groove for		Damped pressure gauges	
quick connectors . . . . .	110	with glycerin filling . . . . .	136
Low-pressure hoses suitable		Damped pressure gauges	
for self-installation max. 45 bar . . . . .	111	with glycerin filling and	
High-pressure hoses for self-installation . . . . .	112	visualization in red/green . . . . .	136
Threaded joints for high-pressure hoses . . . . .	113	Damped pressure gauges	
<b>Fixing material</b> . . . . .	<b>116</b>	with restrictor . . . . .	137
Fixing clips . . . . .	117	High-pressure gauges . . . . .	137
Pipe brackets acc. to DIN 3015 . . . . .	120	<b>Reservoirs</b> . . . . .	<b>138</b>
Cable straps . . . . .	120	Plastic	
Mounting base . . . . .	121	reservoirs . . . . .	139
Fixing bolts . . . . .	121	Oil trough with shut-off valve . . . . .	140
		Metal reservoirs . . . . .	141
		Oil level gauges for metal reservoirs . . . . .	141

<b>Lubricating nipples</b> . . . . .	<b>142</b>	<b>Manual grease guns</b> . . . . .	<b>162</b>
Hydraulic grease nipples according to DIN 71412 . . . . .	.143	Manual grease filler guns . . . . .	163
Button-head grease nipples according to DIN 3404 . . . . .	.143	PowerLuber . . . . .	164
Lubrication fitting block . . . . .	.144	<b>Refill pumps</b> . . . . .	<b>166</b>
Holder with lubricating nipple and fitting . . . . .	.144	Filler cylinder . . . . .	.167
Lubrication nipple manifolds . . . . .	.145	Manual and pneumatic filling pumps 169 . . . . .	168
Lubricating nipple box . . . . .	.145	Compact grease transfer pump GTP-C . . . . .	.170
<b>Filters</b> . . . . .	<b>146</b>	Grease transfer pump GTP . . . . .	.172
Screen filters for oil and fluid grease . . . . .	.147	Electric filling pump EFFP . . . . .	.174
Filter elements for oil and fluid grease filters . . . . .	.147	<b>Cross reference list</b> . . . . .	<b>176</b>
Screen filters for grease . . . . .	.148	<b>Index</b> . . . . .	<b>178</b>
Filter elements for grease filter units . . . . .	.149		
<b>Brushes</b> . . . . .	<b>150</b>		
UC, 233, 068874 . . . . .	.151		
Support for brushes . . . . .	.151		
<b>Tools</b> . . . . .	<b>152</b>		
Pipe cutter . . . . .	153		
Tube bender . . . . .	155		
Tube bending fix . . . . .	156		
Tube cutter . . . . .	.157		
Grease pump set for pressure and function check . . . . .	158		
Drum plug wrench . . . . .	159		
Socket wrench insert for elbows . . . . .	160		
Mounting stud for hose couplings . . . . .	.161		

Electronic part library

# CAD product data

Introduction

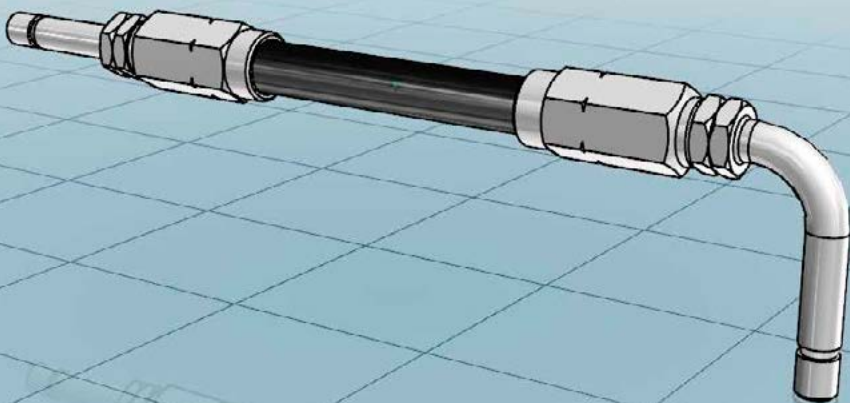

## Find your parts online

3D CAD data, technical drawings and data sheets of SKF fittings and accessories are now available in native format in the online parts library. In addition to enjoying easy CAD downloads, you can configure more complex lubrication system products and integrate them into your design process – completely free of charge. Integrate CAD data seamlessly into your layout plans without any delay.



<https://skf-lubrication.partcommunity.com>



# Lubricants suitable for lubrication systems

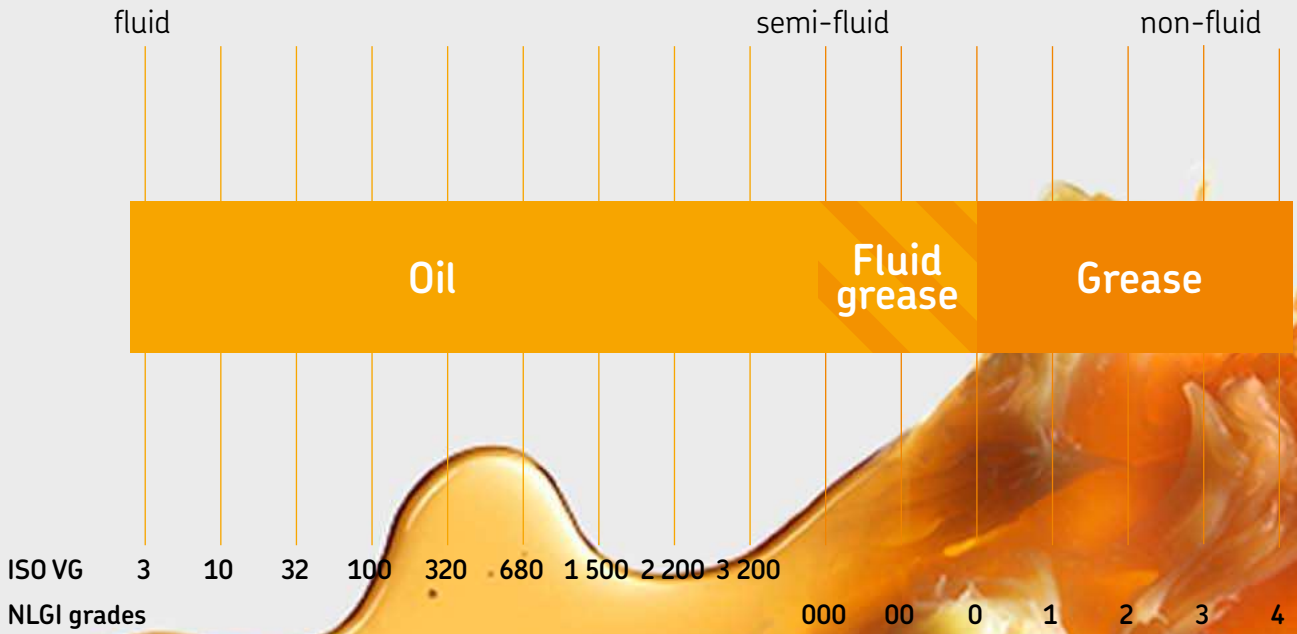

## Oil and fluid grease

The viscosity is an expression of a fluid's internal friction. Oils are classified in ISO VG viscosity classes from 2 to 3 200. NLGI grade 000, 00 and 0 greases are called fluid greases. Different types of oils are available, including mineral oils, organic oils and synthetic oils. A compatibility check is recommended prior to using any oil with SKF lubrication systems.



## Grease

Greases are consistent lubricants (NLGI grade 1–6). They are soft to hard, triple-component mixtures of a base oil as the lubricating fluid, a thickening agent and additives. In most instances, greases of NLGI grade 1 up to 3 are suitable for use in a lubrication system. A compatibility check should be made prior to using any grease with SKF lubrication systems.

Tapered sleeve fittings acc. to DIN 3854/DIN 3862

## Low-pressure fittings for max. 45 bar

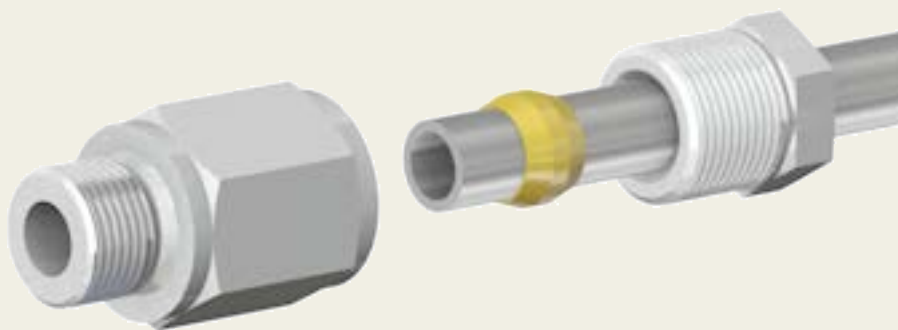

### Description

Solderless pipe unions for metal and plastic pipes are designed for low pressure oil, fluid grease and grease lubrication systems with pressures up to 45 bar and an operating temperature range from -25 to 80 °C. Depending on the selection of metering pipe material, there are two different types of tapered sleeve fittings with different components available: Tapered sleeve fittings for plastic pipes and double-cone sleeve fittings for metal pipes. For both types of unions, a counterbore acc. to DIN 3862 is necessary.

### Features and benefits

- Cost-efficient connection solution for low-pressure systems
- Suitable for oil, fluid grease and grease
- Simple and user-friendly assembly
- Virtually leakage-free union



Tapered sleeve unions

## Applications

- Paper and packaging industry
- Food and beverage industry
- Assembly and automation
- Part assembly lines
- Injection molding
- Mobile on-road
- Machine tools
- Etc.

Tapered sleeve fittings acc. to DIN 3854/DIN 3862

# Provision of counterbore

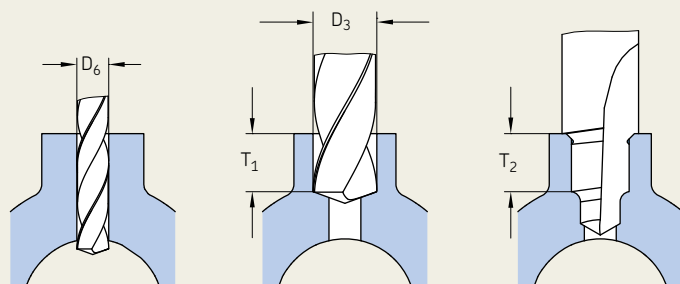

- 1 predrill holes
  - 2 predrill hole to be tapped
  - 3 counterbore with form counterbore up to the stop
- Form counterbore enlarges bore hole diam.  $D_4$  to core hole for ISO thread.



Counterbores for solderless tube connection (DIN 3854/DIN 3862)

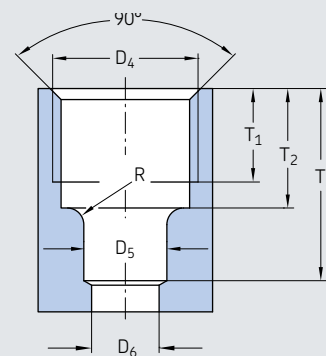

## Description of counterbores

SKF offers a wide range of tapered sleeve fittings with counterbores according to DIN 3862. In addition, it is also possible also to create counterbores by using offered tools as form counterbores.

## Applications

- Small-to-medium machine tools
- Mobile on-road (fleet vehicles, on-road transport)
- Assembly and automation
- Food packaging
- Part assembly lines
- Injection molding

Description	TubeØ	ØD <sub>5</sub> <sup>B11</sup>	ØD <sub>6</sub>	ØD <sub>4</sub>	T <sub>1</sub>	T <sub>2</sub>	T <sub>3</sub>	R
	mm	mm	mm	mm	mm	mm	mm	mm
<b>1102</b> <sup>1)</sup>	2,5	2,5	1,5	M6×0,75	4,5	5,5	8,5	1,3
<b>1404</b>	4	4	3	M8×1	6,5	8,5	12,5	1,6
<b>1406</b>	6	6	4,5	M10×1	7	9	14	1,6
<b>1408</b>	8	8	6,5	M14×1,5	9	11,5	18,5	1,6
<b>1410</b>	10	10	8,5	M16×1,5	9	11,5	19,5	1,6
<b>1412</b>	12	12	10,5	M18×1,5	9,5	12	22	1,6

1) not shown in DIN standard

**! Important note for provision of counterbore:**  
 When using a hand drill, take care not to tilt the counterbore out of the drill axis. To avoid damage, drill steadily without interruption. Increase pressure slightly at the stop.

## Tapered sleeve fittings

### Unions for metal pipes

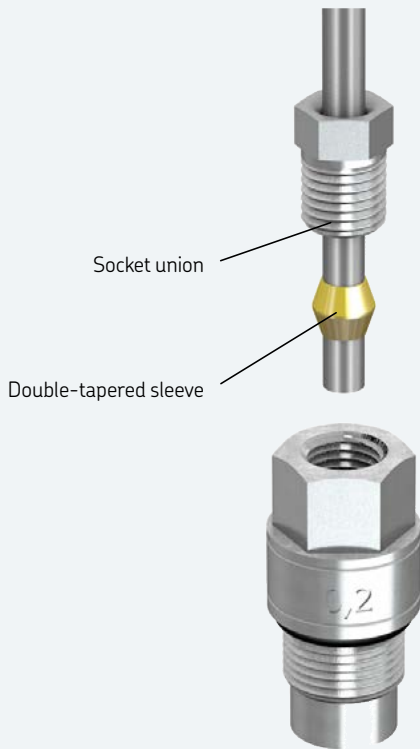

### Unions for plastic pipes

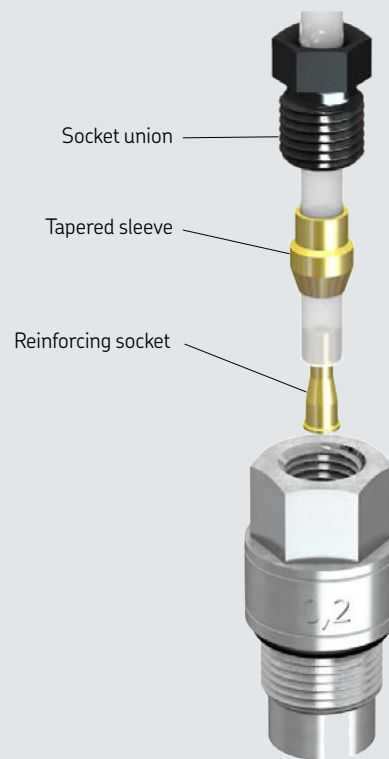

## Solderless pipe unions for metal pipes

### Description

Solderless pipe unions for metal pipes consist of a socket union, a double-cone sleeve and a fitting with counterbore according to DIN 2862.

### Initial assembly

Cut the metal pipe straight to length using a suitable tool, e.g., a pipe cutter. Push the socket union and the double-cone sleeve onto the end of the metal pipe. Insert the end of the metal pipe into the depression until the stop and tighten the socket union finger-tight. Then tighten the socket union again by a maximum of  $1\frac{1}{2}$  revolutions.

### Repeat assembly

After each time the screw union is loosened, the socket union must be firmly retightened (with the same force) as in the initial assembly.

## Solderless pipe unions for plastic pipes

### Description

Solderless pipe unions for plastic pipes consist of a socket union, a tapered sleeve, a reinforcing socket and a fitting with counterbore according to DIN 2862.

### Initial assembly

Cut the plastic pipe straight to length using a suitable tool, e.g., a hose cutter. Insert the reinforcing socket into the end of the plastic pipe to stabilize the end of the pipe being assembled. This prevents the plastic pipe from being constricted during assembly. Push the socket union and the tapered sleeve onto the end of the plastic pipe. Insert the end of the plastic pipe into the depression until the stop and tighten the socket union finger-tight. Then tighten the socket union again by a maximum of  $1\frac{1}{2}$  revolutions.

### Repeat assembly

Each time after the screw union is loosened, the socket union must be firmly retightened (with the same force) as in the initial assembly.

## Solderless pipe union with tapered sleeve

### Form counterbores

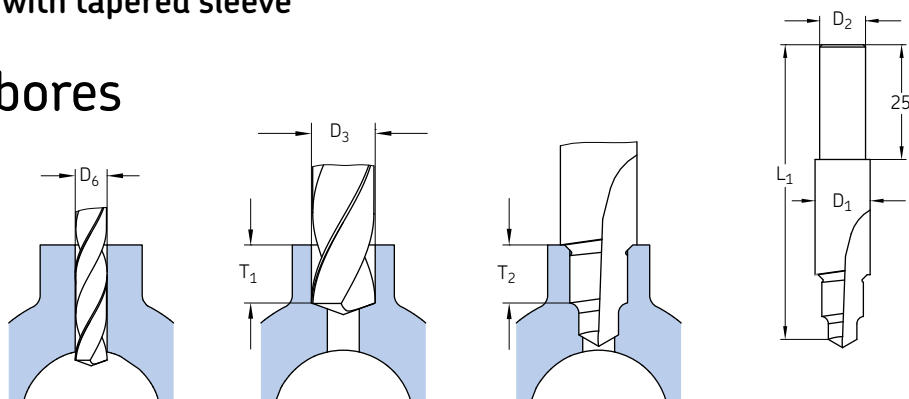

Order number	TubeØ	for counterbores	L <sub>1</sub>	D <sub>1</sub>	D <sub>2</sub>	Twistdrill D <sub>6</sub>	D <sub>3</sub>	T <sub>1</sub>	T <sub>2</sub>
	mm		mm	mm	mm	mm	mm	mm	mm
902-111	2,5	1102	60,5	10	10	1,5	5	4,5	5,5
904-411	4	1404	65	10	10	3	6,5	7,5	8,5
906-411	6	1406	66	12	10	4,5	8,5	8	9
908-411	8	1408	70	16	10	6,5	12	10,5	11,5
910-411	10	1410	72	18	10	8,5	14	10,5	11,5
912-411	12	1412	75	20	10	10,5	16	11	12

## Double-tapered sleeves for metal pipes

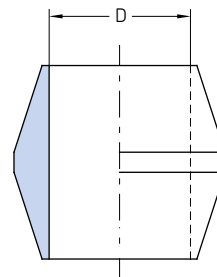

Order number	Designation	TubeØ D	Material	Weight	
				g	lb
Brass					
402-001 <sup>1)</sup>	DOUBLE CONE RING MS D 2,5	2,5	Brass	21	0.05
404-001	DOUBLE CONE RING MS D 4,0	4	Brass	34	0.07
406-001	DOUBLE CONE RING MS D 6,0	6	Brass	66	0.15
408-001	DOUBLE CONE RING MS D 8,0	8	Brass	80	0.18
410-001	DOUBLE CONE RING MS D10,0	10	Brass	100	0.22
412-001	DOUBLE CONE RING MS D12,0	12	Brass	120	0.26
Stainless steel					
404-001-S3	DOUBLE CONE RING VA D 4,0	4	Stainless steel 1.4305	34	0.07
406-001-S3	DOUBLE CONE RING VA D 6,0	6	Stainless steel 1.4305	66	0.15
408-001-S3	DOUBLE CONE RING VA D 8,0	8	Stainless steel 1.4305	80	0.18

<sup>1)</sup> not shown in DIN standard

## Solderless pipe union with tapered sleeve

# Socket unions for metal pipes acc. to DIN 3871

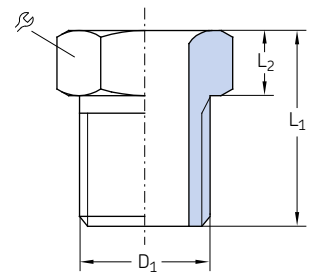

Order number	Designation	TubeØ	D <sub>1</sub>	L <sub>1</sub>	L <sub>2</sub>	ϕ	Material	Weight (100 pcs)		
								mm	mm	mm
Steel, galvanized										
402-002	COMP.NUT	ST D 2,5 M 6x0,75 ZN	2,5	M6x0,75	9	3	7	Steel, galvanized	166	0.37
404-002	COMP.NUT	ST D 4,0 M 8x1,0 ZN	4	M8x1	12	4	8	Steel, galvanized	300	0.66
406-002	COMP.NUT	ST D 6,0 M10x1,0 ZN	6	M10x1	13	4	10	Steel, galvanized	400	0.88
408-202	COMP.NUT	ST D 8,0 M14x1,5 ZN	8	M14x1,5	16	4,5	14	Steel, galvanized	1 000	2.21
410-002	COMP.NUT	ST D10,0M16x1,5 ZN	10	M16x1,5	17	5,5	17	Steel, galvanized	1 400	3.09
412-002	COMP.NUT	ST D12,0 M18x1,5 ZN	12	M18x1,5	18	6	19	Steel, galvanized	1 800	3.97
Stainless steel										
404-002-S3	COMP.NUT	VA D 4,0 M 8x1,0	4	M8x1	12	4	8	Stainless steel 1.4305	300	0.66
406-002-S3	COMP.NUT	VA D 6,0 M10x1,0	6	M10x1	13	4	10	Stainless steel 1.4305	400	0.88
408-202-S3	COMP.NUT	VA D 8,0 M14x1,5	8	M14x1,5	16	4,5	14	Stainless steel 1.4305	1 000	2.21

## Reinforcing sockets for plastic tubes

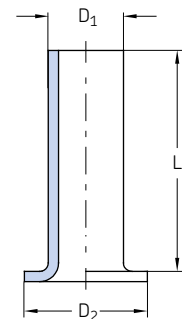

Order number	Designation	TubeØ	D <sub>1</sub>	D <sub>2</sub>	L	Material	Weight	
							mm	mm
402-603	INLET BUSHING MS F.TUBE D 2,5x0,5	2,5x0,5	1,4	2,3	8	Brass	5	0.01
404-603	INLET BUSHING MS F.TUBE D 4,0x0,85	4x0,85	2,2	3,8	10	Brass	8	0.02
406-603	INLET BUSHING MS F.TUBE D 6x1,0	6x1	3,9	5,8	12	Brass	12	0.03
406-613	INLET BUSHING MS F.TUBE D 6x1,25	6x1,25	3,4	5,8	12	Brass	15	0.03
408-603	INLET BUSHING MS F.TUBE D 8x1,25	8x1,25	5,4	7,8	15	Brass	20	0.04
410-603	INLET BUSHING MS F.TUBE D10x1,5	10x1,5	6,9	9,8	18	Brass	24	0.05
412-603	INLET BUSHING MS F.TUBE D12x1,5	12x1,5	8,9	11,8	20	Brass	26	0.06

## Solderless pipe union with tapered sleeve

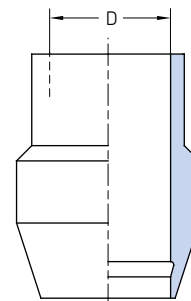
Tapered sleeves for plastic tubes  
acc. to DIN 3862

Order number	Designation	Tube Ø D	Material	Weight (100 pcs)	
				g	lb
		mm			
402-611	TAPER CUTT.RING MS D 2,5	2,5	Brass	100	0.22
404-611	TAPER CUTT.RING MS D 4,0	4	Brass	120	0.26
406-611	TAPER CUTT.RING MS D 6,0	6	Brass	160	0.35
408-611	TAPER CUTT.RING MS D 8,0	8	Brass	200	0.44
410-611	TAPER CUTT.RING MS D10,0	10	Brass	250	0.55
412-611	TAPER CUTT.RING MS D12,0	12	Brass	300	0.66

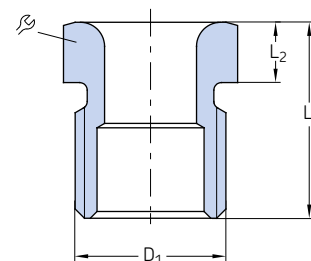
Socket unions for plastic tubes  
acc. to DIN 3871

Order number	Designation	Tube Ø D <sub>1</sub>		L <sub>1</sub>	L <sub>2</sub>	⌀	Material	Weight (100 pcs)	
		mm	mm					g	lb
Steel, black finished									
402-612	COMP.NUT ST D 2,5 M 6x0,75	2,5	M6×0,75	9	3	7	Steel, black finished	100	0.22
404-612	COMP.NUT ST D 4,0 M 8x1,0	4	M8×1	12	4	8	Steel, black finished	200	0.44
406-612	COMP.NUT ST D 6,0 M10x1,0	6	M10×1	13	4	10	Steel, black finished	300	0.66
408-612	COMP.NUT ST D 8,0 M14x1,5	8	M14×1,5	16	4,5	14	Steel, black finished	900	1.98
410-612	COMP.NUT ST D10,0 M16x1,5	10	M16×1,5	17	5,5	17	Steel, black finished	1 300	2.87
412-612	COMP.NUT ST D12,0 M18x1,5	12	M18×1,5	18	6	19	Steel, black finished	1 700	3.75
Brass									
404-612-MS	COMP.NUT MS D 4,0 M 8x1,0	4	M8×1	12	4	8	Brass	200	0.44
406-612-MS	COMP.NUT MS D 6,0 M10x1,0	6	M10×1	13	4	10	Brass	300	0.66
408-612-MS	COMP.NUT MS D 8,0 M14x1,5	8	M14×1,5	16	4,5	14	Brass	900	1.98
410-612-MS	COMP.NUT MS D10,0 M16x1,5	10	M16×1,5	17	5,5	17	Brass	1 300	2.87



## Solderless pipe union with tapered sleeve

# Connectors with tapered thread

Tapered threads are used without washers; sealed by tapered outer thread and sealant according to DIN 3852-1.

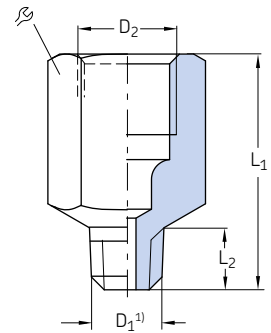

Order number	Designation	TubeØ	D <sub>1</sub> <sup>1)</sup>	D <sub>2</sub>	L <sub>1</sub>	L <sub>2</sub>	⌀	Material	Weight
		mm	mm	mm	mm	mm	mm		g lb
402-003K	CONNECTING PIECE ST D 2,5 M 6x0,75K ZN	2,5	M6x0,75 tap.	M6x0,75	11,5	4,5	8	Steel, galvanized	2 0.004
402-006K	CONNECTING PIECE ST D 2,5 M 8x1,0K ZN	2,5	M8x1 tap.	M6x0,75	15	8	9	Steel, galvanized	5 0.011
402-008K	CONNECTING PIECE ST D 2,5 M10x1,0K ZN	2,5	M10x1 tap.	M6x0,75	16	7,5	12	Steel, galvanized	11 0.024
404-662K	CONNECTING PIECE ST D 4,0 M 6K ZN	4	M6 tap.	M8x1	19	5	11	Steel, galvanized	8 0.018
404-663K	CONNECTING PIECE ST D 4,0 M 6K ZN	4	M6 tap.	M8x1	20	6	11	Steel, galvanized	8 0.018
404-673K	CONNECTING PIECE ST D 4,0 M 6x0,75K ZN	4	M6x0,75 tap.	M8x1	20	6	11	Steel, galvanized	8 0.018
404-047K	CONNECTING PIECE ST D 4,0 M 7K ZN	4	M7 tap.	M8x1	20	6	11	Steel, galvanized	9 0.02
404-003K	CONNECTING PIECE ST D 4,0 M 8x1,0K ZN	4	M8x1 tap.	M8x1	17	7,4	11	Steel, galvanized	6 0.013
404-045	CONNECTING PIECE ST D 4,0 M 8x1,0K ZN	4	M8x1 tap.	M8x1	62,5	7,4	11	Steel, galvanized	40 0.088
404-006K	CONNECTING PIECE ST D 4,0 M10x1,0K ZN	4	M10x1 tap.	M8x1	16	7,4	11	Steel, galvanized	7 0.015
401-004-512	CONNECTING PIECE ST D 4,0 M10x1,0K ZN	4	M10x1 tap.	M8x1	25	7,4	11	Steel, galvanized	14 0.031
404-040K	CONNECTING PIECE ST D 4,0 R1/8K ZN	4	R 1/8	M8x1	16	6	11	Steel, galvanized	7 0.015
404-040K-US	CONNECTING PIECE ST D 4,0 1/8NPTF ZN	4	1/8 NPTF	M8x1	20	6,7	11	Steel, galvanized	10 0.022
404-054K	CONNECTING PIECE ST D 4,0 R1/4K ZN	4	R 1/4	M8x1	14	9	14	Steel, galvanized	11 0.024
404-072	CONNECTING PIECE ST D 4,0 1/4 28UNF ZN	4	1/4-28 UNF	M8x1	20	5,6	11	Steel, galvanized	9 0.02
401-004-903	CONNECTING PIECE ST D 4,0 1/4BSF ZN	4	1/4 BSF	M8x1	20	5	11	Steel, galvanized	9 0.02
401-004-904	CONNECTING PIECE ST D 4,0 3/16BSF ZN	4	1/6 BSF	M8x1	18	5	11	Steel, galvanized	7 0.015
406-004K	CONNECTING PIECE ST D 6,0 M10x1,0K ZN	6	M10x1 tap.	M10x1	23	7,4	14	Steel, galvanized	20 0.044
456-004K	CONNECTING PIECE ST D 6,0 R1/8K ZN	6	R 1/8	M10x1	21	6	14	Steel, galvanized	15 0.033
406-054K	CONNECTING PIECE ST D 6,0 R1/4K ZN	6	R 1/4	M10x1	20	9	17	Steel, galvanized	22 0.049

<sup>1)</sup> Tapered thread according to DIN 158, short, resp. according to DIN 2999.

## Solderless pipe union with tapered sleeve

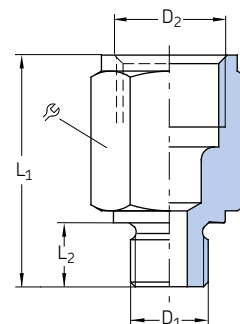
Connectors with cylindrical thread  
acc. to DIN 71428

Order number	Designation	Tube Ø	D <sub>1</sub>	D <sub>2</sub>	L <sub>1</sub>	L <sub>2</sub>	⊘	Material	Weight	
		mm	mm	mm	mm	mm	mm		g	lb
Steel, galvanized										
402-004	CONNECTING PIECE ST D 2,5 M 6 ZN	2,5	M6	M6x0,75	13	5,5	9	Steel, galvanized	3	0.007
402-003	CONNECTING PIECE ST D 2,5 M 6x0,75 ZN	2,5	M6x0,75	M6x0,75	13	5,5	9	Steel, galvanized	3	0.007
402-006	CONNECTING PIECE ST D 2,5 M 8x1,0 ZN	2,5	M8x1	M6x0,75	15	7,5	11	Steel, galvanized	7	0.015
404-004	CONNECTING PIECE ST D 4,0 M 8x1,0 ZN	4	M8x1	M8x1	24	14	11	Steel, galvanized	9	0.02
404-005	CONNECTING PIECE ST D 4,0 M 8x1,0 ZN	4	M8x1	M8x1	32	22	11	Steel, galvanized	14	0.031
404-061	CONNECTING PIECE ST D 4,0 M 5 ZN	4	M5	M8x1	20	5,5	11	Steel, galvanized	9	0.02
404-063	CONNECTING PIECE ST D 4,0 M 8 ZN	4	M8	M8x1	22	8	11	Steel, galvanized	10	0.022
404-003	CONNECTING PIECE ST D 4,0 M 8x1,0 ZN	4	M8x1	M8x1	18	7,5	11	Steel, galvanized	6	0.013
404-006	CONNECTING PIECE ST D 4,0 M10x1,0 ZN	4	M10x1	M8x1	18	7,5	14	Steel, galvanized	13	0.029
404-040	CONNECTING PIECE ST D 4,0 G1/8A ZN	4	G 1/8 A	M8x1	18	8	14	Steel, galvanized	13	0.029
404-162	CONNECTING PIECE ST D 4,0 M12x1,0 ZN	4	M12x1	M8x1	18	9	17	Steel, galvanized	19	0.042
404-164	CONNECTING PIECE ST D 4,0 M14x1,5 ZN	4	M14x1,5	M8x1	18	9	17	Steel, galvanized	21	0.046
406-158	CONNECTING PIECE ST D 6,0 M 8x1,0 ZN	6	M8x1	M10x1	23	7,5	14	Steel, galvanized	38	0.084
406-004	CONNECTING PIECE ST D 6,0 M10x1 ZN	6	M10x1	M10x1	18	7,5	14	Steel, galvanized	10	0.022
406-162	CONNECTING PIECE ST D 6,0 M12x1,0 ZN	6	M12x1	M10x1	19	9	17	Steel, galvanized	18	0.04
406-054	CONNECTING PIECE ST D 6,0 G1/4A ZN	6	G 1/4 A	M10x1	20	10	17	Steel, galvanized	20	0.044
301-005	CONNECTING PIECE ST D 6,0 M14x1,5 ZN	6	M14x1,5	M10x1	18	9	17	Steel, galvanized	18	0.04
406-166	CONNECTING PIECE ST D 6,0 M16x1,5 ZN	6	M16x1,5	M10x1	19	9	19	Steel, galvanized	28	0.062
406-055	CONNECTING PIECE ST D 6,0 G3/8A ZN	6	G 3/8 A	M10x1	21	10	22	Steel, galvanized	41	0.09
408-004	CONNECTING PIECE ST D 8,0 M10x1 ZN	8	M10x1	M14x1,5	28	7,5	17	Steel, galvanized	25	0.055
408-154	CONNECTING PIECE ST D 8,0 G1/8A ZN	8	G 1/8 A	M14x1,5	29	8	17	Steel, galvanized	26	0.057
408-160	CONNECTING PIECE ST D 8,0 G1/4A ZN	8	G 1/4 A	M14x1,5	30	16	17	Steel, galvanized	22	0.049
408-162	CONNECTING PIECE ST D 8,0 M12x1 ZN	8	M12x1	M14x1,5	29	9	17	Steel, galvanized	26	0.057
301-020	CONNECTING PIECE ST D 8,0 G1/4A ZN	8	G 1/4 A	M14x1,5	23	10	17	Steel, galvanized	16	0.035
301-001	CONNECTING PIECE ST D 8,0 M14x1,5 ZN	8	M14x1,5	M14x1,5	26	9	17	Steel, galvanized	23	0.051
408-005	CONNECTING PIECE ST D 8,0 M16x1,5 ZN	8	M16x1,5	M14x1,5	22	9	19	Steel, galvanized	30	0.066
408-006	CONNECTING PIECE ST D 8,0 M18x1,5 ZN	8	M18x1,5	M14x1,5	22	10	22	Steel, galvanized	40	0.088
408-022	CONNECTING PIECE ST D 8,0 M22x1,5 ZN	8	M22x1,5	M14x1,5	24	12	27	Steel, galvanized	71	0.157
Brass										
267-001.17	CONNECTING PIECE MS D 6,0 G1/4A	6	G 1/4 A	M10x1	24	8	14	Brass	18	0.04
406-163	CONNECTING PIECE MS D 6,0 M12x1	6	M12x1	M10x1	19	9	17	Brass	20	0.044
D301-005-MS	CONNECTING PIECE MS D 6,0 M14x1,5	6	M14x1,5	M10x1	20	9	17	Brass	24	0.053
406-167	CONNECTING PIECE MS D 6,0 M16x1,5	6	M16x1,5	M10x1	19	9	19	Brass	31	0.068
267-001.19	CONNECTING PIECE MS D 6,0 M18x1,5	6	M18x1,5	M10x1	21	10	22	Brass	71	0.157
D408-004-MS	CONNECTING PIECE MS D 8,0 M10x1	8	M10x1	M14x1,5	29	7,5	17	Brass	29	0.064
D301-001-MS	CONNECTING PIECE MS D 8,0 M14x1,5	8	M14x1,5	M14x1,5	28	9	17	Brass	29	0.064
D301-020-MS	CONNECTING PIECE MS D 8,0 G1/4A	8	G 1/4 A	M14x1,5	30	10	17	Brass	30	0.066
267-001.13	CONNECTING PIECE MS D 8,0 G1/2A	8	G 1/2 A	M14x1,5	24	12	27	Brass	71	0.157
Stainless steel										
301-005-S3	CONNECTING PIECE VA D 6,0 M14x1,5	6	M14x1,5	M10x1	18	9	17	Stainless steel 1.4305	19	0.042
406-004-S3	CONNECTING PIECE VA D 6,0 M10x1,0	6	M10x1	M10x1	18	7,5	14	Stainless steel 1.4305	10	0.022
406-158-S3	CONNECTING PIECE VA D 6,0 M 8x1,0	6	M8x1	M10x1	23	7,5	14	Stainless steel 1.4305	15	0.033
301-020-S3	CONNECTING PIECE VA D 6,0 G1/4A	8	G 1/4 A	M14x1,5	23	10	17	Stainless steel 1.4305	17	0.037

## Solderless pipe union with tapered sleeve

# Connectors with cylindrical thread acc. to DIN 71428

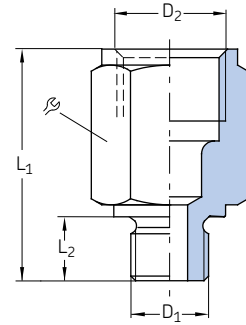

Tapered sleeve unions

Order number	Designation	Tube Ø	D <sub>1</sub>	D <sub>2</sub>	L <sub>1</sub>	L <sub>2</sub>	⌀	Material	Weight	
									mm	mm
410-160	CONNECTING PIECE ST D10,0 M10x1,0 ZN	10	M10x1	M16x1,5	30	7.5	19	Steel, galvanized	32	0.071
410-162	CONNECTING PIECE ST D10,0 M12x1,0 ZN	10	M12x1	M16x1,5	31	9	19	Steel, galvanized	30	0.066
410-163	CONNECTING PIECE ST D10,0 G1/4A ZN	10	G1/4A	M16x1,5	30	10	19	Steel, galvanized	30	0.066
410-164	CONNECTING PIECE ST D10,0 M14x1,5 ZN	10	M14x1,5	M16x1,5	29	9	19	Steel, galvanized	30	0.066
410-169	CONNECTING PIECE ST D10,0 G1/4A ZN	10	G1/4A	M16x1,5	52	16	19	Steel, galvanized	32	0.071
410-004	CONNECTING PIECE ST D10,0 M16x1,5 ZN	10	M16x1,5	M16x1,5	23	9	19	Steel, galvanized	21	0.046
410-018	CONNECTING PIECE ST D10,0 M18x1,5 ZN	10	M18x1,5	M16x1,5	24	10	22	Steel, galvanized	37	0.082
410-171	CONNECTING PIECE ST D10,0 G1/2A ZN	10	G1/2A	M16x1,5	24	12	27	Steel, galvanized	58	0.128
410-022	CONNECTING PIECE ST D10,0 M22x1,5 ZN	10	M22x1,5	M16x1,5	24	12	27	Steel, galvanized	64	0.141
412-162	CONNECTING PIECE ST D12,0 M12x1,0 ZN	12	M12x1	M18x1,5	35	9	22	Steel, galvanized	52	0.115
412-163	CONNECTING PIECE ST D12,0 G1/4A ZN	12	G1/4A	M18x1,5	35	10	22	Steel, galvanized	51	0.112
412-164	CONNECTING PIECE ST D12,0 M14x1,5 ZN	12	M14x1,5	M18x1,5	33	9	22	Steel, galvanized	46	0.101
412-169	CONNECTING PIECE ST D12,0 G1/4A ZN	12	G1/4A	M18x1,5	41	16	22	Steel, galvanized	49	0.108
412-004	CONNECTING PIECE ST D12,0 M18x1,5 ZN	12	M18x1,5	M18x1,5	24	10	22	Steel, galvanized	28	0.062
412-014	CONNECTING PIECE ST D12,0 M22x1,5 ZN	12	M22x1,5	M18x1,5	26	12	27	Steel, galvanized	63	0.139

## Solderless pipe union with tapered sleeve

# Bracketed connectors

504-004

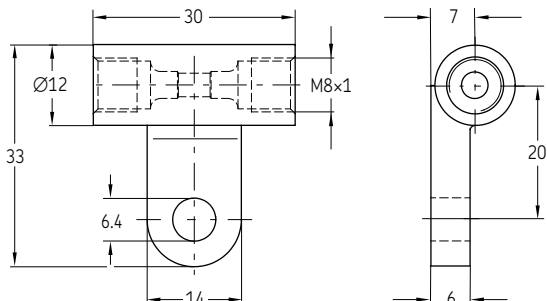

506-010

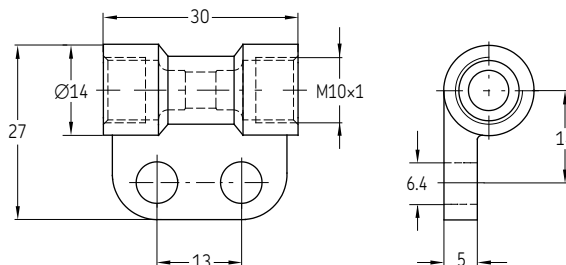

Order number	Designation	TubeØ	Material	Weight	
				g	lb
Die-cast zinc <b>504-004</b>	TUBE FITTING ZN G4+BRACKET	4	Die-cast zinc	26	0.06
Brass <b>506-010</b>	TUBE FITTING MS G6+BRACKET	6	Brass	30	0.07

DAR506, DAR508

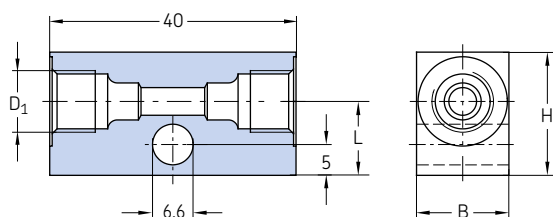

DAR510, DAR510-S1

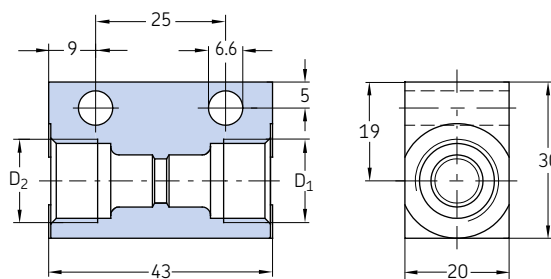

Order number	Designation	TubeØ	D <sub>1</sub>	D <sub>2</sub>	B	H	L <sub>1</sub>	Material	Weight	
									g	lb
Aluminum <b>DAR506</b>	TUBE CONNECTOR,AL 2x M10x1	6	M10x1	-	15	20	12	Aluminum	26	0.06
<b>DAR508</b>	TUBE CONNECTOR,AL 2x M14x1	8	M14x1,5	-	20	25	15	Aluminum	41	0.09
Steel, galvanized <b>DAR510</b>	TUBE CONNECTOR,ST 2x M16x1 ZN	10	M16x1,5	M16x1,5	-	-	-	Steel, galvanized	140	0.31
<b>DAR510-S1</b>	TUBE CONNECT.,ST 1x M14x1,5/1x M16x1,5ZN	8/10	M14x1,5	M16x1,5	-	-	-	Steel, galvanized	150	0.33

## Solderless pipe union with tapered sleeve

### Bracketed connectors

DAR524

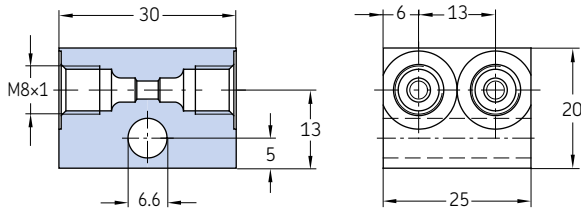

DAR534

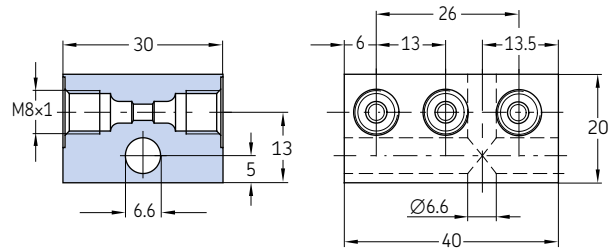

Order number	Designation	TubeØ	Material	Weight	
				g	lb
DAR524	TUBE CONNECTOR,ST DOUBLE 4x M 8x1 ZN	4	Steel, galvanized	90	0.2
DAR534	TUBE CONNECTOR,ST TRIPLE 6x M 8x1 ZN	4	Steel, galvanized	150	0.33

### Tube-to-tube connector with air vent acc. to DIN 3862

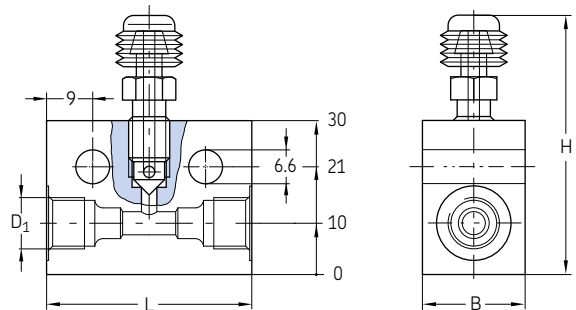

Order number	Designation	TubeØ	D <sub>1</sub>	B	H	L <sub>1</sub>	Material	Weight	
								g	lb
995-001-104	TUBE FITTING AL G4 M 8x1,0 VENT.DEVICE	4	M8x1	20	50	40	Aluminum	68	0.15
995-001-106	TUBE FITTING AL G6 M10x1,0 VENT.DEVICE	6	M10x1	20	50	40	Aluminum	49	0.11

Solderless pipe union with tapered sleeve

T-connectors acc. to DIN 71433

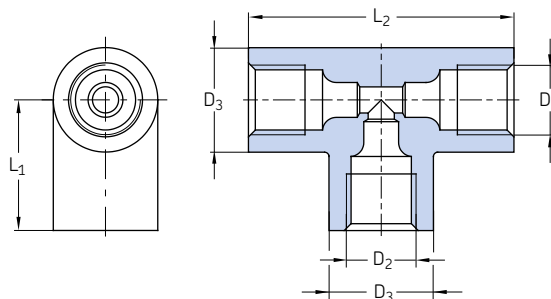

Order number	Designation	TubeØ	D <sub>1</sub>	D <sub>2</sub>	D <sub>3</sub>	L <sub>1</sub>	L <sub>2</sub>	Form	Material	Weight	
										g	lb
504-008	TUBE FITTING ZN T4 M 8x1,0	4	M8x1	M8x1	12	15	30,5	A	Die-cast zinc	20	0.04
506-008	TUBE FITTING ZN T6 M10x1,0	6	M10x1	M10x1	14	18	36	A	Die-cast zinc	31	0.07
510-102	TUBE FITTING ZN T10 M16x1,5	10	M16x1,5	M16x1,5	20	25	50	A	Die-cast zinc	62	0.14
506-408	TUBE FITTING ZN TR6/4 M10x1,0	6/4	M10x1	M8x1	14	18	36	B	Die-cast zinc	33	0.07

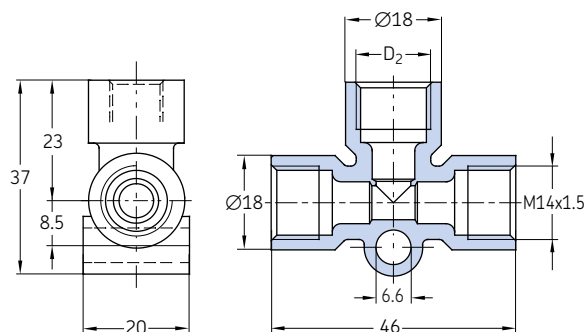

Order number	Designation	TubeØ	D <sub>2</sub>	Form	Material	Weight	
						g	lb
508-602-2	TUBE FITTING ZN TR8/6	8/6	M10x1	B	Die-cast zinc	58	0.13
508-002-2	TUBE FITTING ZN TR8	8	M14x1,5	A	Die-cast zinc	50	0.11

## Solderless pipe union with tapered sleeve

# T-connectors acc. to DIN 71433

504-045

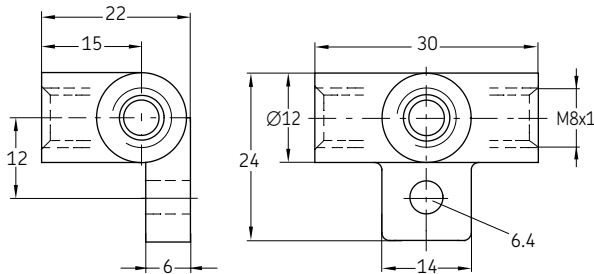

DY964

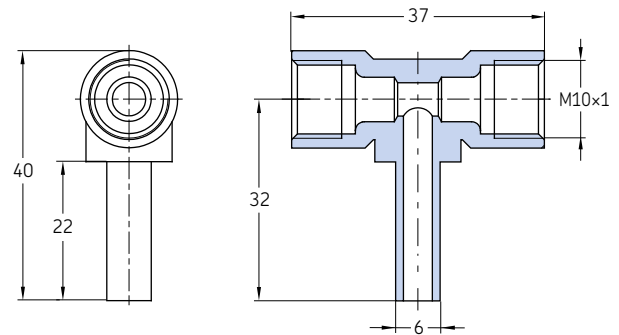

Order number	Designation	Tube Ø	Material	Weight	
				g	lb
504-045	TUBE FITTING ZN T4	4	Die-cast zinc	26	0.06
DY964	TUBE FITTING MST 6	6	Brass	38	0.08

DAT506 – DAT510

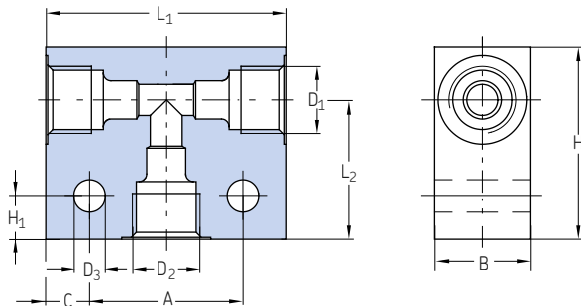

DAT510-S1

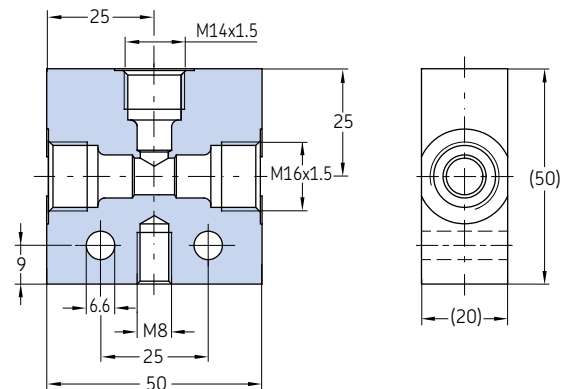

Order number	Designation	Tube Ø	D <sub>1</sub>	D <sub>2</sub>	D <sub>3</sub>	A	B	C	H	H <sub>1</sub>	L <sub>1</sub>	L <sub>2</sub>	Form	Material	Weight	
															g	lb
Aluminum																
DAT506	TEE,AL 3x M10x1	6	M10x1	M10x1	6,6	22	20	9	30	9	40	20	A	Aluminum	55	0.12
DAT508	TEE,AL 3x M14x1,5	8	M14x1,5	M14x1,5	6,6	32	20	9	40	9	50	29	A	Aluminum	90	0.2
DAT512	TEE,AL 3x M18x1,5	12	M18x1,5	M18x1,5	6,6	42	25	9	40	9	60	29	A	Aluminum	123	0.27
DAT510-S5	TEE,AL 2x M16x1,5/1x M14x1,5	6	M16x1,5	M10x1	7	25	25	13,5	40	15	52	29	B	Aluminum	120	0.26
Steel, galvanized																
DAT510	TEE,ST 3x M16x1,5 ZN	10	M16x1,5	M16x1,5	7	25	20	13,5	40	15	52	29	A	Steel, galv.	230	0.51
DAT510-S1	TEE,ST 2x M16x1,5/1x M14x1,5 ZN	8 (1x), 10 (2x)	M16x1,5	M14x1,5	6,6	25	20	12,5	50	9	50	25	B	Steel, galv.	306	0.67

## Solderless pipe union with tapered sleeve

# Bulkhead connectors with tapered thread

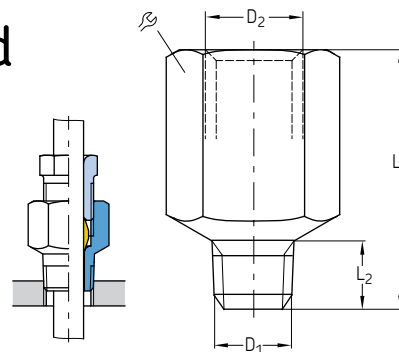

Order number	Designation	TubeØ	D <sub>1</sub> <sup>1)</sup>	D <sub>2</sub>	L <sub>1</sub>	L <sub>2</sub>	β	Material	Weight	
									mm	mm
404-003DK	ADAPTER ST 4 M 8x1,0 ZN	4	M8x1 tap.	M8x1	17	7,4	11	Steel, galvanized	6	0.013
404-006DK	ADAPTER ST 4 M10x1,0 ZN	4	M10x1 tap.	M8x1	16	7,4	11	Steel, galvanized	7	0.015
406-004DK	ADAPTER ST 6 M10x1,0 ZN	6	M10x1 tap.	M10x1	18	7,4	14	Steel, galvanized	10	0.022
301-001DK	ADAPTER ST 8 M14x1,5 ZN	8	M14x1,5 tap.	M14x1,5	24	11	17	Steel, galvanized	19	0.042
410-004DK	ADAPTER ST10 M16x1,5 ZN	10	M16x1,5 tap.	M16x1,5	24	11	19	Steel, galvanized	22	0.049

<sup>1)</sup> Tapered thread according to DIN 158 tap. short.

## Tube-to-tube connectors

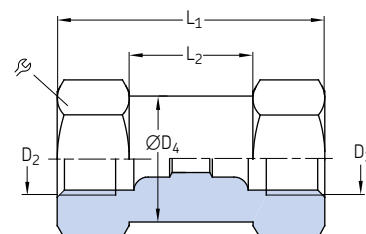

Order number	Designation	TubeØ	D <sub>2</sub>	D <sub>3</sub>	ØD <sub>4</sub>	L <sub>1</sub>	L <sub>2</sub>	β	Material	Weight	
										mm	mm
404-010	TUBE FITTING ST G 4 ZN	4	M8x1	M8x1	10,8	27	13	11	Steel, galvanized	14	0.03
406-010	TUBE FITTING ST G 6 ZN	6	M10x1	M10x1	13,8	30	10	14	Steel, galvanized	25	0.06
406-805	TUBE FITTING ST GR 6/8 ZN	6/8	M14x1,5	M10x1	16,8	35	11	17	Steel, galvanized	43	0.09
408-010	TUBE FITTING ST G 8 ZN	8	M14x1,5	M14x1,5	16,8	40	14	17	Steel, galvanized	40	0.09
410-010	TUBE FITTING ST G 10 ZN	10	M16x1,5	M16x1,5	18,8	42	13	19	Steel, galvanized	54	0.12
412-010	TUBE FITTING ST G 12 ZN	12	M18x1,5	M18x1,5	21,8	48	18	22	Steel, galvanized	85	0.19



## Solderless pipe union with tapered sleeve

# Straight bulkhead fittings acc. to DIN 71429

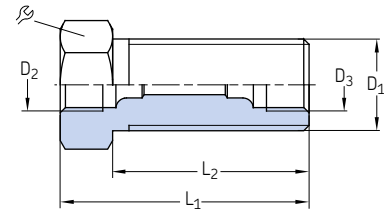

Order number	Designation	TubeØ		D <sub>2</sub>	D <sub>3</sub>	L <sub>1</sub>	L <sub>2</sub>	R	Material	Weight	
		D <sub>1</sub> <sup>1)</sup>								g	lb
		mm	mm	mm	mm	mm	mm	mm			
404-008	TUBE FITTING ST SV 4 M14x1,5 ZN	4	M14x1,5	M8x1	M8x1	27	19	17	Steel, galvanized	30	0.07
404-009	TUBE FITTING ST SV 4 M14x1,5 ZN	4	M14x1,5	M8x1	M8x1	38	30	17	Steel, galvanized	39	0.09
406-008	TUBE FITTING ST SV 6 M14x1,5 ZN	6	M14x1,5	M10x1	M10x1	30	20	17	Steel, galvanized	30	0.07
406-005	TUBE FITTING ST SV 6/8 M16x1,5 ZN	6/8	M16x1,5	M14x1,5	M10x1	35	23	19	Steel, galvanized	38	0.08
408-008	TUBE FITTING ST SV 8 M20x1,5 ZN	8	M20x1,5	M14x1,5	M14x1,5	40	28	24	Steel, galvanized	75	0.17
410-008	TUBE FITTING ST SV10 M20x1,5 ZN	10	M20x1,5	M16x1,5	M16x1,5	42	27	24	Steel, galvanized	73	0.16
412-008	TUBE FITTING ST SV12 M24x1,5 ZN	12	M24x1,5	M18x1,5	M18x1,5	48	33	27	Steel, galvanized	114	0.25

## Reducing piece

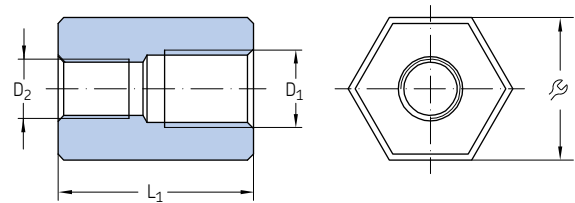

Order number	Designation	TubeØ		L <sub>1</sub>	R	Material	Weight		
		D <sub>1</sub>	D <sub>2</sub>				g	lb	
		mm	in	mm	mm				
44-1755-2019	TB.STUD RED ST 4 G1/4I xM10x1I SW24 ZN	4	G 1/4	M10x1	33	24	Steel, galvanized	100	0.22

## Solderless pipe union with tapered sleeve

### Threaded sockets

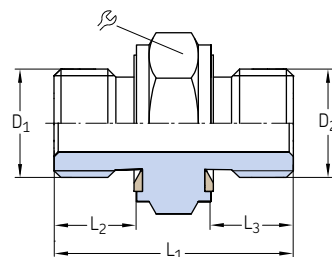

Order number	Designation	D <sub>1</sub>	D <sub>2</sub>	L <sub>1</sub>	L <sub>2</sub>	L <sub>3</sub>	⌀	Seals	Material	Weight	
		in	in	mm	mm	mm				mm	g
<b>402-116-161</b>	THREADED PIECE ST L29 G1/4AZN	G 1/4 A	G 1/4 A	29	10	10	19	NBR	Steel, galvanized	30	0.07
<b>402-116-165</b>	THREADED PIECE ST L37 G1/2ZN	G 1/2	G 1/2	37	10	12	32	NBR	Steel, galvanized	100	0.22

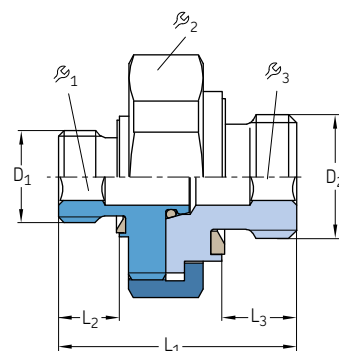

Order number	Designation	D <sub>1</sub>	D <sub>2</sub>	L <sub>1</sub>	L <sub>2</sub>	L <sub>3</sub>	⌀ <sub>1</sub>	⌀ <sub>2</sub>	⌀ <sub>3</sub>	Seals	Material	Weight	
				mm	mm	mm	mm	mm	mm			mm	g
Steel, galvanized													
<b>995-014-014</b>	CONNECTOR ST G1/4A-G1/4AZN	G 1/4 A	G 1/4 A	26	8	8	4	24	5	NBR	Steel, galvanized	40	0.09
Brass													
<b>995-340-000</b>	CONNECTOR MS M10x1,M10x1	M10×1	M10×1	19,5	6,5	6,5	4	16	4	NBR	Brass	13	0.03
<b>995-340-350</b>	CONNECTOR MS M10x1,M12x1	M10×1	M12×1	21	6,5	7,2	4	19	5	NBR	Brass	20	0.04
<b>995-350-000</b>	CONNECTOR MS M12x1,M12x1	M12×1	M12×1	21,5	7	7,2	5	19	5	NBR	Brass	20	0.04
<b>995-340-000-S8</b>	CONNECTOR MS M10x1,M10x1	M10×1	M10×1	19,5	6,5	6,5	4	16	4	FKM	Brass	13	0.03
<b>995-340-350-S8</b>	CONNECTOR MS M10x1,M12x1	M10×1	M12×1	21	6,5	7,2	4	19	5	FKM	Brass	18	0.04
<b>995-350-000-S8</b>	CONNECTOR MS M12x1,M12x1	M12×1	M12×1	21,5	7	7,2	5	19	5	FKM	Brass	22	0.05

## Solderless pipe union with tapered sleeve

### Threaded sockets

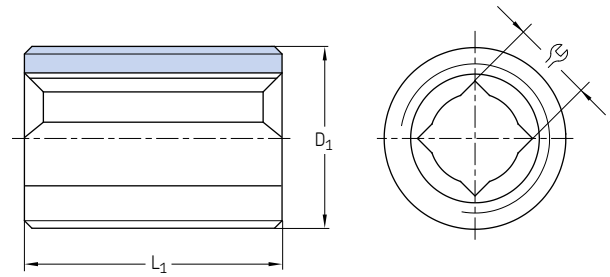

Order number	Designation	D <sub>1</sub>	L <sub>1</sub>	β	Material	Weight	
						g	lb
Steel							
404-203	THREADED PIECE ST L13 M 8x1,0	M8x1	13	3,5	Steel	3	0.007
406-203	THREADED PIECE ST L15 M10x1,0	M10x1	15	3,5	Steel	6	0.013
406-243-B <sup>1)</sup>	THREADED PIECE ST L18 M10x1,0	M10x1	18	3,5	Steel	7	0.015
408-243-B <sup>1)</sup>	THREADED PIECE ST L19 M12x1,0	M12x1	19	5,5	Steel	9	0.02
458-012	THREADED PIECE ST L17 M12x1,0	M12x1	17	5,5	Steel	8	0.018
458-012-B <sup>1)</sup>	THREADED PIECE ST L17 M12x1,0	M12x1	17	5,5	Steel	8	0.018
408-023	THREADED PIECE ST L18 M14x1,5	M14x1,5	18	5,5	Steel	13	0.029
410-003	THREADED PIECE ST L19 M16x1,5	M16x1,5	19	7	Steel	16	0.035
410-003-B <sup>1)</sup>	THREADED PIECE ST L19 M16x1,5	M16x1,5	19	7	Steel	17	0.037
Stainless steel							
408-033-S3	THREADED PIECE VA L15 G1/4A	G 1/4 A	15	5,5	Stainless steel 1.4305	9	0.02

<sup>1)</sup> Coated with microencapsulated adhesive

406-103, 408-103, 853-750-024

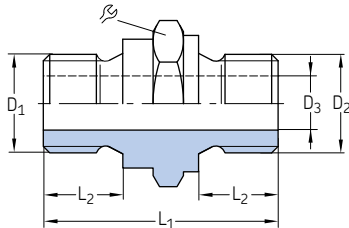

406-233

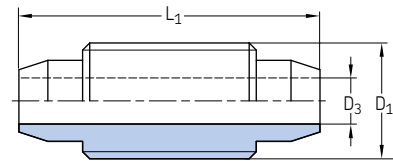

Order number	Designation	D <sub>1</sub>	D <sub>2</sub>	D <sub>3</sub>	L <sub>1</sub>	L <sub>2</sub>	β	Material	Weight	
									g	lb
Steel, galvanized										
406-103	THREADED PIECE ST L20 M10x1,0xM12x1,0 ZN	M10x1	M12x1	5	20	6	14	Steel, galvanized	14	0.03
408-103	THREADED PIECE ST L21 M12x1,0xM14x1,5 ZN	M12x1	M14x1,5	6	21	7	17	Steel, galvanized	21	0.05
853-750-024	THREADED PIECE ST L31 G1/4Ax G1/4A ZN	G 1/4 A	G 1/4 A	7	31	10,5	19	Steel, galvanized	29	0.06
Brass										
406-233	THREADED PIECE MS L26 M10x1,0	M10x1	-	4	26	-	-	Brass	8	0.02

Solderless pipe union with tapered sleeve

# Elbow bulkhead fittings acc. to DIN 71429

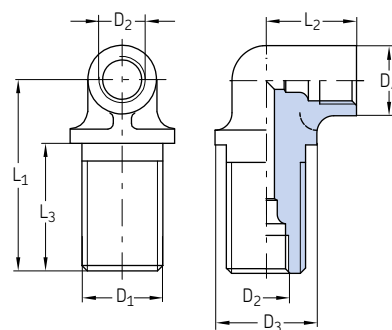

Order number	Designation	TubeØ	D <sub>1</sub>	D <sub>2</sub>	D <sub>3</sub>	D <sub>4</sub>	L <sub>1</sub>	L <sub>2</sub>	L <sub>3</sub>	Material	Weight	
											mm	mm
Die-cast zinc <b>504-003</b>	TUBE FITTING ZN WSV 4 M14x1,5	4	M14x1,5	M8x1	18	12	33	16	22	Die-cast zinc	30	0.07
Brass <b>504-103</b>	TUBE FITTING MS WSV 4 M14x1,5	4	M14x1,5	M8x1	18	12	33	18	22	Brass	46	0.1
<b>506-004</b>	TUBE FITTING MS WSV 6 M14x1,5	6	M14x1,5	M10x1	16,5	14	27	17,5	15	Brass	41	0.09

# Elbows with cylindrical thread acc. to DIN 71433

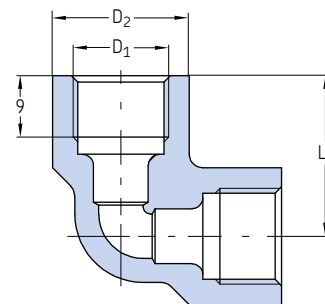

Order number	Designation	TubeØ	D <sub>1</sub>	D <sub>2</sub>	L <sub>1</sub>	Material	Weight	
							mm	mm
<b>408-013</b>	TUBE FITTING ZN W 8 M14x1,5	8	M14x1,5	20	23,5	Die-cast zinc	40	0.09
<b>410-013</b>	TUBE FITTING ZN W10M16x1,5	10	M16x1,5	21	26	Die-cast zinc	58	0.13

## Solderless pipe union with tapered sleeve

# Elbows with tapered thread acc. to DIN 71429

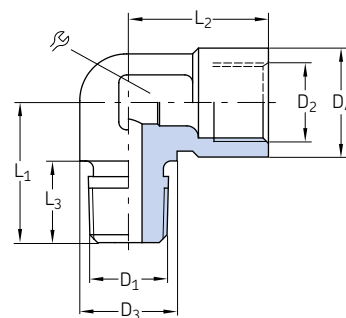

Order number	Designation	TubeØ D <sub>1</sub> <sup>1)</sup>	D <sub>2</sub>	D <sub>3</sub>	D <sub>4</sub>	L <sub>1</sub>	L <sub>2</sub>	L <sub>3</sub>	Material	Weight	
		mm	mm	mm	mm	mm	mm	mm		g lb	
<b>504-510K</b>	TB.FITT.,ANGLE D4 M10X1,0KAXM 8X1 I ZN 4	M10×1 tap.	M8×1	13	13	21	16	10	14	Die-cast zinc	24 0.05
<b>514-018K</b>	TB.FITT.,ANGLE D4 R 1/8KAXM 8X1 I ZN 4	R 1/8	M8×1	13	13	21	16	10	14	Die-cast zinc	23 0.05
<b>506-508K</b>	TB.FITT.,ANGLE D6 M 8X1,0KAXM10X1 I ZN 6	M8×1 tap.	M10×1	12,5	14	18	18	10,5	14	Die-cast zinc	18 0.04
<b>506-510K</b>	TB.FITT.,ANGLE D6 M10X1,0KAXM10X1 I ZN 6	M10×1 tap.	M10×1	12,5	14	18	18	10,5	14	Die-cast zinc	20 0.04
<b>506-511-K</b>	TB.FITT.,ANGLE D6 R 1/8KAXM10X1 I ZN 6	R 1/8	M10×1	12,5	14	18	18	10,5	14	Die-cast zinc	20 0.04
<b>506-512K</b>	TB.FITT.,ANGLE D6 M12X1,0KAXM10X1 I ZN 6	M12×1 tap.	M10×1	12,5	14	18	18	10,5	14	Die-cast zinc	21 0.05
<b>508-512K</b>	TB.FITT.,ANGLE D8 M12X1,0KAXM14X1,5 I ZN 8	M12×1 tap.	M14×1,5	14	19,5	19,5	24	10	14	Die-cast zinc	34 0.07

<sup>1)</sup> Tapered thread according to DIN 158 tap. short, resp. according to DIN 2999.

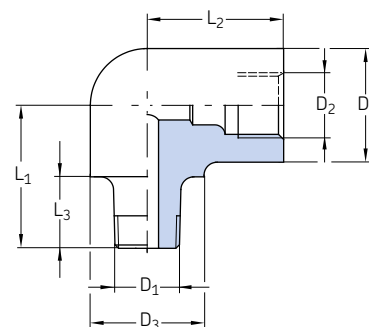

Order number	Designation	TubeØ D <sub>1</sub> <sup>1)</sup>	D <sub>2</sub>	D <sub>3</sub>	D <sub>4</sub>	L <sub>1</sub>	L <sub>2</sub>	L <sub>3</sub>	Material	Weight	
		mm	mm	mm	mm	mm	mm	mm		g lb	
Steel											
<b>502-206K</b>	ELBOW PIPE ST 2,5 M 6K	2,5	M6 tap.	M6×0,75	—	8	10	9,5	6	Steel	6 0.01
<b>403-006-651</b>	ELBOW PIPE ST 6 R1/4K	6	R 1/4	M10×1	14	14	17	17,5	8,5	Steel	32 0.07
Brass											
<b>506-202K</b>	ELBOW PIPE MS 6 M10x1,0K	6	M10×1 tap.	M10×1	17	17	22	21	11	Brass	60 0.13

<sup>1)</sup> Tapered thread according to DIN 158 tap. short, resp. according to DIN 2999.

## Solderless pipe union with tapered sleeve

### Elbows with tapered thread acc. to DIN 71429

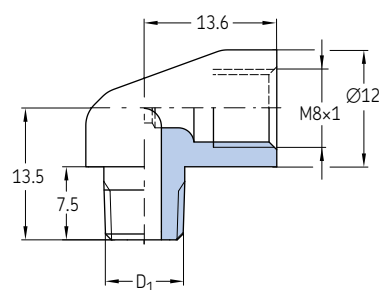

Order number	Designation	TubeØ	D <sub>1</sub> <sup>1)</sup>	Material	Weight	
					mm	g
504-200K	ELBOW PIPE MS 4 M 6K	4	M6 tap.	Brass	14	0.03
504-201K	ELBOW PIPE MS 4 M 8x1,0K	4	M8x1 tap.	Brass	20	0.04
504-202K	ELBOW PIPE MS 4 M10x1,0K	4	M10x1 tap.	Brass	16	0.04
504-203K	ELBOW PIPE MS 4 M 6x0,75K	4	M6x0.75 tap.	Brass	14	0.03
514-018K-S1	ELBOW PIPE MS 4 R1/8K	4	R 1/8	Brass	20	0.04

<sup>1)</sup>Tapered thread according to DIN 158. short, resp. according to DIN 2999.

### Elbows with tube end for pipe union for installation in counterbores acc. to DIN 3854/DIN 3862

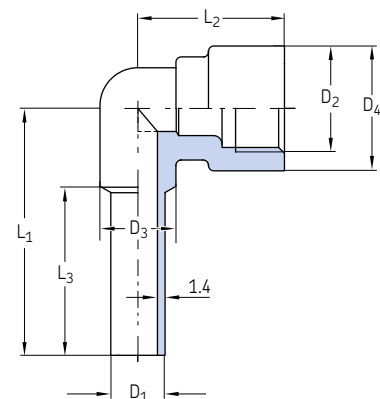

Order number	Designation	TubeØ	D <sub>1</sub>	D <sub>2</sub>	D <sub>3</sub>	D <sub>4</sub>	L <sub>1</sub>	L <sub>2</sub>	L <sub>3</sub>	Material	Weight	
											mm	mm
DY958	ELBOW PIPE MS D6	6	6	M10x1	8	14	30,8	21	22	Brass	23	0.05
DY960	ELBOW PIPE MS D8	8	8	M14x1,5	11	18	37	24,5	27	Brass	37	0.08
DY961	ELBOW PIPE MS D10	10	10	M16x1,5	15	23	42,5	26,5	29	Brass	73	0.16
DY962	ELBOW PIPE MS D12	12	12	M18x1,5	15	23	46	26,5	32	Brass	62	0.14

## Solderless pipe union with tapered sleeve

# Banjo fittings acc. to DIN 71430 Form A

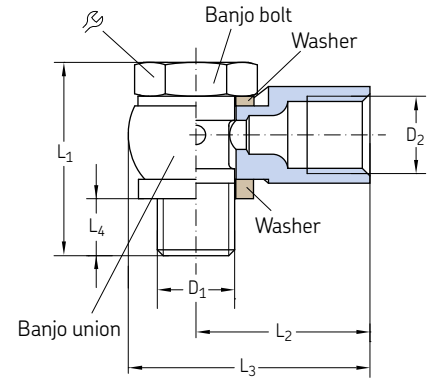

Order number	Designation	Tube Ø D <sub>1</sub>	D <sub>2</sub>	L <sub>1</sub>	L <sub>2</sub>	L <sub>3</sub>	L <sub>4</sub>	⌀	Banjo bolt	Banjo union	Weight (total)		
		mm	mm	mm	mm	mm	mm	mm			g	lb	
Steel, galvanized													
502-161 <sup>1)</sup>	TUBE FITTING SWVE 2,5 M 6	2,5	M6	M6×0,75	20	13	19	4,5	9	502-056	502-051	11	0.02
502-101 <sup>1)</sup>	TUBE FITTING SWVE 2,5 M 6×0,75	2,5	M6×0,75	M6×0,75	18	13	19	5	9	502-053	502-051	10	0.02
502-102 <sup>1)</sup>	TUBE FITTING SWVE 2,5 M 8×1,0	2,5	M8×1	M6×0,75	20	14	21	6,5	11	502-054	502-052	15	0.03
504-161 <sup>1)</sup>	TUBE FITTING SWVE 4 M 6	4	M6	M8×1	20	17	24	4,1	9	502-056	504-651	15	0.03
504-162 <sup>1)</sup>	TUBE FITTING SWVE 4 M 6×0,75	4	M6×0,75	M8×1	18	17	24	4,5	9	502-053	504-651	14	0.03
504-411 <sup>1)</sup>	TUBE FITTING SWVE 4 M 8	4	M8	M8×1	23	18	25	7,5	11	502-154	504-851	20	0.04
504-401 <sup>1)</sup>	TUBE FITTING SWVE 4 M 8×1,0	4	M8×1	M8×1	20	18	25	5,9	11	502-054	504-851	17	0.04
Steel, galvanized bolt and die-cast zinc union													
504-101	TUBE FITTING SWVE 4 M 8×1,0	4	M8×1	M8×1	26	18	25	6,5	11	504-073	504-072	23	0.05
504-102	TUBE FITTING SWVE 4 M10×1,0	4	M10×1	M8×1	26	19	27,5	6,5	14	504-054	504-052	30	0.07
504-108	TUBE FITTING SWVE 4 G1/8A	4	G 1/8 A	M8×1	27	19	27,5	6,8	14	504-027	504-052	32	0.07
506-140	TUBE FITTING SWVE 6 M10×1,0	6	M10×1	M10×1	26	21	28,5	6,5	14	504-054	506-033	33	0.07
506-142	TUBE FITTING SWVE 6 M12×1,0	6	M12×1	M10×1	34	25	35,2	7,5	17	558-012	506-030	60	0.13
506-012	TUBE FITTING SWVE 6 M14×1,5	6	M14×1,5	M10×1	34	25	35,2	7,5	17	508-006	506-005	60	0.13
506-145	TUBE FITTING SWVE 6 M16×1,5	6	M16×1,5	M10×1	35	30	41	8,7	19	510-017	506-034	90	0.20
506-108	TUBE FITTING SWVE 6 G1/8A	6	G 1/8 A	M10×1	27	21	28,5	7	14	504-027	506-033	33	0.07
506-214	TUBE FITTING SWVE 6 G1/4A	6	G 1/4 A	M10×1	35	25	35,2	8,5	17	508-023	506-005	60	0.13
508-142	TUBE FITTING SWVE 8 M12×1,0	8	M12×1	M14×1,5	34	27	37	7,5	17	558-012	508-030	63	0.14
508-144	TUBE FITTING SWVE 8 M14×1,5	8	M14×1,5	M14×1,5	34	27	37	7,5	17	508-006	508-007	61	0.13
508-145	TUBE FITTING SWVE 8 M16×1,5	8	M16×1,5	M14×1,5	35	30	41	8,7	19	510-017	508-054	80	0.18
508-024	TUBE FITTING SWVE 8 G1/4A	8	G 1/4 A	M14×1,5	35	27	37	8,5	17	508-023	508-007	59	0.13
510-142	TUBE FITTING SWVE 10 M12×1,0	10	M12×1	M16×1,5	34	30	40	7,5	17	558-012	510-041	70	0.15
510-145	TUBE FITTING SWVE 10 M16×1,5	10	M16×1,5	M16×1,5	35	30	41	10,7	19	510-017	510-044	80	0.18
510-024	TUBE FITTING SWVE 10 G1/4A	10	G 1/4 A	M16×1,5	35	30	40	7,5	17	508-023	510-023	65	0.14

<sup>1)</sup> Miniature design, banjo union steel

## Solderless pipe union with tapered sleeve

# Banjo fittings acc. to DIN 71430 Form B

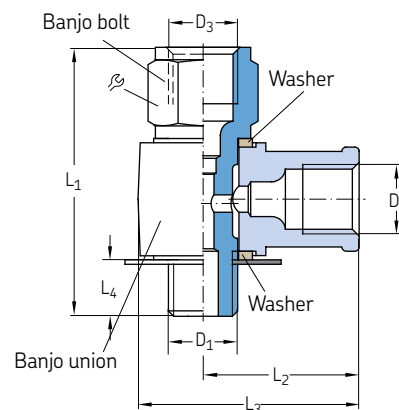

Order number	Designation	Tube Ø	D <sub>1</sub>	D <sub>2</sub>	D <sub>3</sub>	L <sub>1</sub>	L <sub>2</sub>	L <sub>3</sub>	L <sub>4</sub>	Banjo bolt	Banjo union	Weight (total)		
			mm	mm	mm	mm	mm	mm	mm			mm	g	lb
Steel, galvanized bolt and die-cast zinc union														
<b>504-114</b>	TUBE FITTING LE 4 M 8x1,0	4	M8x1	M8x1	M8x1	31	18	25,5	6,5	11	<b>504-075</b>	<b>504-072</b>	24	0.05
<b>504-115</b>	TUBE FITTING LE 4 M10x1,0	4	M10x1	M8x1	M8x1	31	19	27,5	6,5	14	<b>504-056</b>	<b>504-052</b>	34	0.07
<b>504-105</b>	TUBE FITTING LE 4/6 M10x1,0	4/6	M10x1	M8x1	M10x1	33	19	27,5	6,5	14	<b>506-006</b>	<b>504-052</b>	34	0.07
<b>405-619-061</b>	TUBE FITTING LE 4/6 G1/8A	4/6	G 1/8 A	M8x1	M10x1	33	19	27,5	6,3	14	<b>402-606-191</b>	<b>504-052</b>	33	0.07
<b>506-114</b>	TUBE FITTING LE 6 M10x1,0	6	M10x1	M10x1	M10x1	33	21	28,5	6,3	14	<b>506-006</b>	<b>506-033</b>	35	0.08
<b>506-342</b>	TUBE FITTING LE 6 M12x1,0	6	M12x1	M10x1	M10x1	38	25	35,2	7,5	17	<b>558-612</b>	<b>506-030</b>	62	0.14
<b>506-101</b>	TUBE FITTING LE 6 M14x1,5	6	M14x1,5	M10x1	M10x1	40	25	35,2	7,5	17	<b>508-303</b>	<b>506-005</b>	70	0.15
<b>586-342</b>	TUBE FITTING LE 6/8 M12x1,0	6/8	M12x1	M10x1	M14x1,5	44	25	35,2	7,5	17	<b>558-812</b>	<b>506-030</b>	64	0.14
<b>506-013</b>	TUBE FITTING LE 6/8 M14x1,5	6/8	M14x1,5	M10x1	M14x1,5	43	25	35,2	7,5	17	<b>508-008</b>	<b>506-005</b>	61	0.13
<b>506-345</b>	TUBE FITTING LE 6/10 M12x1,0	6/10	M12x1	M10x1	M16x1,5	48,5	25	35	7,7	19	<b>558-912</b>	<b>506-030</b>	77	0.17
<b>506-346</b>	TUBE FITTING LE 6/10 M16x1,5	6/10	M16x1,5	M10x1	M16x1,5	50	30	41	8,7	19	<b>510-010</b>	<b>506-034</b>	100	0.22
<b>508-342</b>	TUBE FITTING LE 8 M12x1,0	8	M12x1	M14x1,5	M14x1,5	44	27	37	7,5	17	<b>558-812</b>	<b>508-030</b>	67	0.15
<b>508-012</b>	TUBE FITTING LE 8 M14x1,5	8	M14x1,5	M14x1,5	M14x1,5	43	27	37	7,5	17	<b>508-008</b>	<b>508-007</b>	63	0.14
<b>508-034</b>	TUBE FITTING LE 8 G1/4A	8	G 1/4 A	M14x1,5	M14x1,5	44	27	37	7,5	17	<b>508-033</b>	<b>508-007</b>	65	0.14
<b>568-342</b>	TUBE FITTING LE 8/6 M12x1,0	8/6	M12x1	M14x1,5	M10x1	38	27	37	7,5	17	<b>558-612</b>	<b>508-030</b>	65	0.14
<b>508-304</b>	TUBE FITTING LE 8/6 M14x1,5	8/6	M14x1,5	M14x1,5	M10x1	40	27	37	7,5	17	<b>508-303</b>	<b>508-007</b>	66	0.15
<b>508-345</b>	TUBE FITTING LE 8/10 M12x1,0	8/10	M12x1	M14x1,5	M16x1,5	48,5	27	37	7,7	19	<b>558-912</b>	<b>508-030</b>	80	0.18
<b>508-346</b>	TUBE FITTING LE 8/10 M16x1,5	8/10	M16x1,5	M14x1,5	M16x1,5	50	30	41	8,7	19	<b>510-010</b>	<b>508-054</b>	93	0.21
<b>510-342</b>	TUBE FITTING LE 10 M12x1,0	10	M12x1	M16x1,5	M16x1,5	48,5	30	40	7,5	19	<b>558-912</b>	<b>510-041</b>	81	0.18
<b>510-344</b>	TUBE FITTING LE 10 M16x1,5	10	M16x1,5	M16x1,5	M16x1,5	50	30	41	8,7	19	<b>510-010</b>	<b>510-044</b>	89	0.20
<b>510-343</b>	TUBE FITTING LE 10 G1/4A	10	G 1/4 A	M16x1,5	M16x1,5	48,5	30	40	7,5	19	<b>558-913</b>	<b>510-023</b>	78	0.17
<b>510-346</b>	TUBE FITTING LE 10/6 M16x1,5	10/6	M16x1,5	M16x1,5	M10x1	50	30	41	8,7	19	<b>506-018</b>	<b>510-044</b>	96	0.21
<b>510-341</b>	TUBE FITTING LE 10/8 M12x1,0	10/8	M12x1	M16x1,5	M14x1,5	44	30	40	7,5	17	<b>558-812</b>	<b>510-041</b>	69	0.15



## Solderless pipe union with tapered sleeve

# Banjo fittings acc. to DIN 71430 Form C

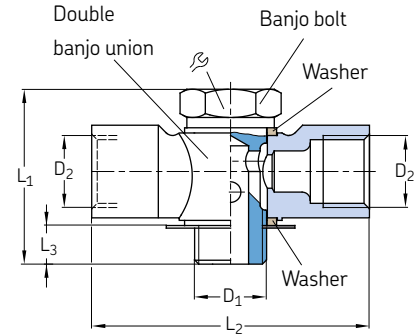

Tapered sleeve unions

Order number	Designation	Tube		D <sub>1</sub>	D <sub>2</sub>	L <sub>1</sub>	L <sub>2</sub>	L <sub>3</sub>	∩	Banjo bolt	Material	Double banjo union	Material	Weight (total)	
		∅												mm	mm
504-109	TUBE FITTING TH4 M 8x1,0	4	M8x1	M8x1	26	38	6,5	11		504-073	Steel, galv.	504-071	Die-cast zinc	31	0.07
504-112	TUBE FITTING TH4 M10x1,0	4	M10x1	M8x1	26	38	6,5	14		504-054	Steel, galv.	504-051	Die-cast zinc	35	0.08
506-242	TUBE FITTING TH6 M12x1,0	6	M12x1	M10x1	34	48	7,5	17		558-012	Steel, galv.	506-032	Die-cast zinc	71	0.16
506-025	TUBE FITTING TH6 M14x1,5	6	M14x1,5	M10x1	34	48	7,5	17		508-006	Steel, galv.	506-007	Die-cast zinc	70	0.15
508-242	TUBE FITTING TH8 M12x1,0	8	M12x1	M14x1,5	34	54	7,5	17		558-012	Steel, galv.	508-032	Die-cast zinc	77	0.17
508-013	TUBE FITTING TH8 M14x1,5	8	M14x1,5	M14x1,5	34	54	7,5	17		508-006	Steel, galv.	508-005	Die-cast zinc	77	0.17
508-025	TUBE FITTING TH8 G1/4A	8	G 1/4A	M14x1,5	35	54	7,5	17		508-023	Steel, galv.	508-005	Die-cast zinc	77	0.17
510-242	TUBE FITTING TH10 M12x1,0	10	M12x1	M16x1,5	34	60	7,5	17		558-012	Steel, galv.	510-042	Die-cast zinc	83	0.18

# Banjo fittings acc. to DIN 71430 Form D

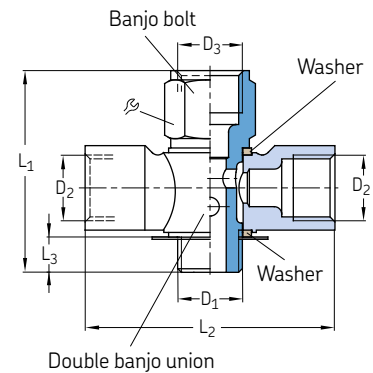

Order number	Designation	Tube ∅	D <sub>1</sub>	D <sub>2</sub>	D <sub>3</sub>	L <sub>1</sub>	L <sub>2</sub>	L <sub>3</sub>	∩	Banjo bolt	Double banjo union	Weight (total)	
												mm	mm
Steel, galvanized bolt and die-cast zinc union													
504-110	TUBE FITTING TH4 M 8x1,0	4	M8x1	M8x1	M8x1	31	38	6,5	11	504-071	504-071	32	0.07
504-111	TUBE FITTING TH4 M10x1,0	4	M10x1	M8x1	M8x1	31	38	6,5	14	504-056	504-051	37	0.08
504-106	TUBE FITTING TH4/6 M10x1,0	4/6	M10x1	M8x1	M10x1	33	38	6,5	14	506-006	504-051	37	0.08
506-442	TUBE FITTING TH6 M12x1,0	6	M12x1	M10x1	M10x1	38	48	7,5	17	558-612	506-032	70	0.15
506-014	TUBE FITTING TH6 M14x1,5	6	M14x1,5	M10x1	M10x1	40	48	7,5	17	508-303	506-007	73	0.16
586-442	TUBE FITTING TH6/8 M12x1,0	6/8	M12x1	M10x1	M14x1,5	44	48	7,5	17	558-812	506-032	72	0.16
506-026	TUBE FITTING TH6/8 M14x1,5	6/8	M14x1,5	M10x1	M14x1,5	43	48	7,5	17	508-008	506-007	70	0.15
508-442	TUBE FITTING TH8 M12x1,0	8	M12x1	M14x1,5	M14x1,5	44	54	7,5	17	558-812	508-032	68	0.15
508-014	TUBE FITTING TH8 M14x1,5	8	M14x1,5	M14x1,5	M14x1,5	43	54	7,5	17	508-008	508-005	79	0.17
568-442	TUBE FITTING TH8/6 M12x1,0	8/6	M12x1	M14x1,5	M10x1	38	54	7,5	17	558-612	508-032	80	0.18
508-305	TUBE FITTING TH8/6 M14x1,5	8/6	M14x1,5	M14x1,5	M10x1	40	54	7,5	17	508-303	508-005	90	0.20
510-442	TUBE FITTING TH10 M12x1,0	10	M12x1	M16x1,5	M16x1,5	48,5	60	7,5	19	558-912	510-042	99	0.22

## Solderless pipe union with tapered sleeve

# Banjo fittings, rotatable

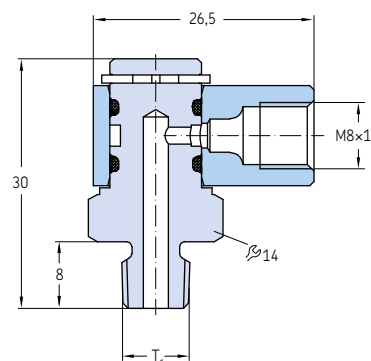

Order number	Designation	Tube ØD	Thread T <sub>1</sub>	Thread <sub>2</sub>	Speed max.	Oil pressure max.		Air pressure max.		Material	Weight	
						bar	psi	bar	psi		g	lb
405-549-049	BANJO FITTING MOVABLE M 8x1A x M8I	4	M8x1 tap.	M8x1	1	45	650	-	-	Brass	41	0.09
405-551-049	BANJO FITTING MOVABLE M10x1A x M8I	4	M10x1 tap.	M8x1	1	45	650	-	-	Brass	40	0.09

## Banjo fitting with indicator pin for lubricant distributor

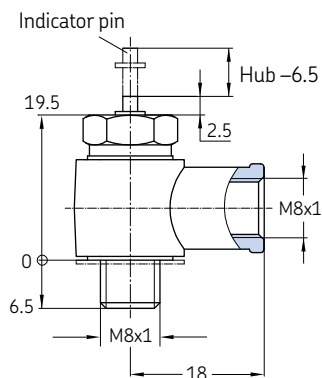

Order number	Designation	Tube Ø	Material	Weight	
				g	lb
169-200-008	TUBE FITTING SWVE 4 M 8x1,0+K	4	Steel, galvanized	24	0.05

## Solderless pipe union with tapered sleeve

# Rotating joints

401-504-192

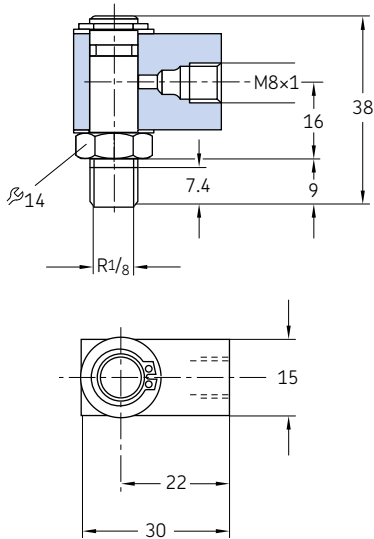

401-504-292

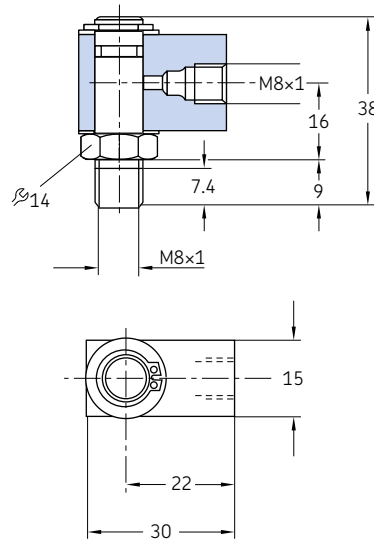

401-506-313

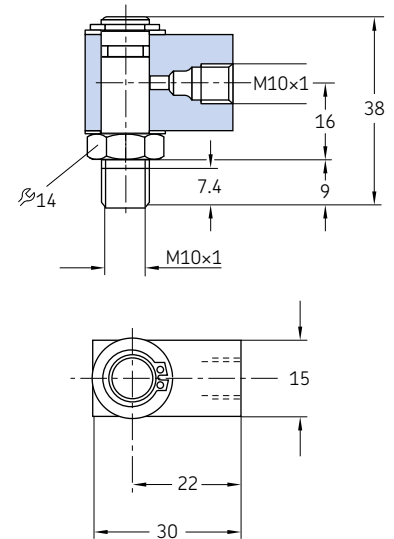

Order number	Designation	Tube ØD mm	Thread <sub>1</sub> mm	Thread <sub>2</sub> mm	Speed max. min <sup>-1</sup>	Oil pressure max.		Air pressure max.		Material	Weight	
						bar	psi	bar	psi		g	lb
401-504-192	ROTATING JOINT MS 4 R1/8	4	R1/8	M8x1	100	30	435	8	116	Brass	81	0.18
401-504-292	ROTATING JOINT MS 4 M 8x1	4	M8x1	M8x1	100	30	435	8	116	Brass	80	0.18
401-506-313	ROTATING JOINT MS 6 M10x1	6	M10x1	M10x1	100	30	435	8	116	Brass	77	0.17

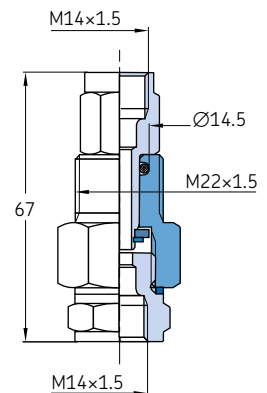

Order number	Designation	Tube ØD mm	Thread <sub>1</sub> mm	Thread <sub>2</sub> mm	Speed max. min <sup>-1</sup>	Oil pressure max.		Air pressure max.		Material	Weight	
						bar	psi	bar	psi		g	lb
408-120	ROTATING JOINT ST 8 M14x1,5	8	M14x1,5	M14x1,5	20	10	145	-	-	Steel	200	0.44

## Solderless pipe union with tapered sleeve

### Cross joints

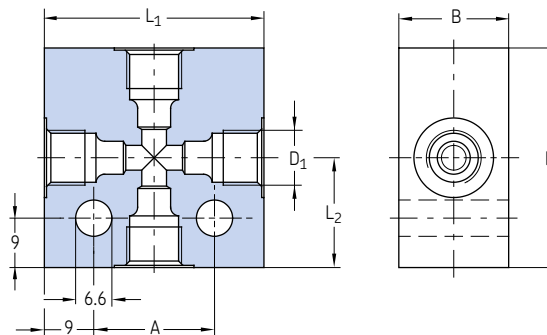

Order number	Designation	Tube Ø	D <sub>1</sub>	A	B	H	L <sub>1</sub>	L <sub>2</sub>	Material	Weight	
		mm	mm	mm	mm	mm	mm	mm		g	lb
<b>DAK504-S1</b>	CROSS PIECE,AL 1x M10x1/3x M 8x1	4/6	M10x1/ M8x1	22	20	40	40	20	Aluminum	78	0.17
<b>DAK506</b>	CROSS PIECE,AL 4x M10x1	6	M10x1	22	20	40	40	20	Aluminum	75	0.17
<b>DAK508</b>	CROSS PIECE,AL 4x M14x1,5	8	M14x1,5	32	20	50	50	25	Aluminum	110	0.24
<b>DAK510</b>	CROSS PIECE,AL 4x M16x1,5	10	M16x1,5	25	20	56	50	28	Aluminum	115	0.25
<b>DAK512</b>	CROSS PIECE,AL 4x M18x1,5	12	M18x1,5	42	25	60	60	30	Aluminum	194	0.43

## Solderless pipe union with tapered sleeve

### Cross joints

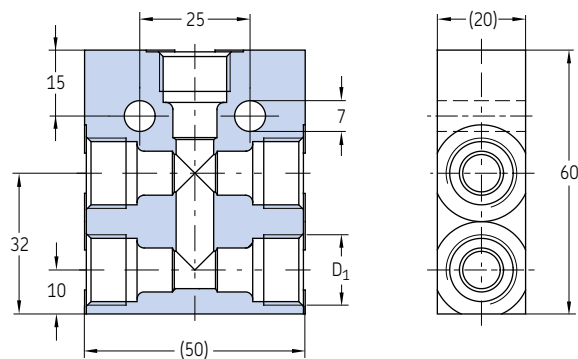

Order number	Designation	Tube Ø	D <sub>1</sub>	Material	Weight	
					g	lb
DAK510-S1	TEE,ST 5x M16x1,5 ZN	10	M16x1,5	Steel, galvanized	322	0.71

## High-pressure cutting sleeve unions acc. to ISO 8334-1

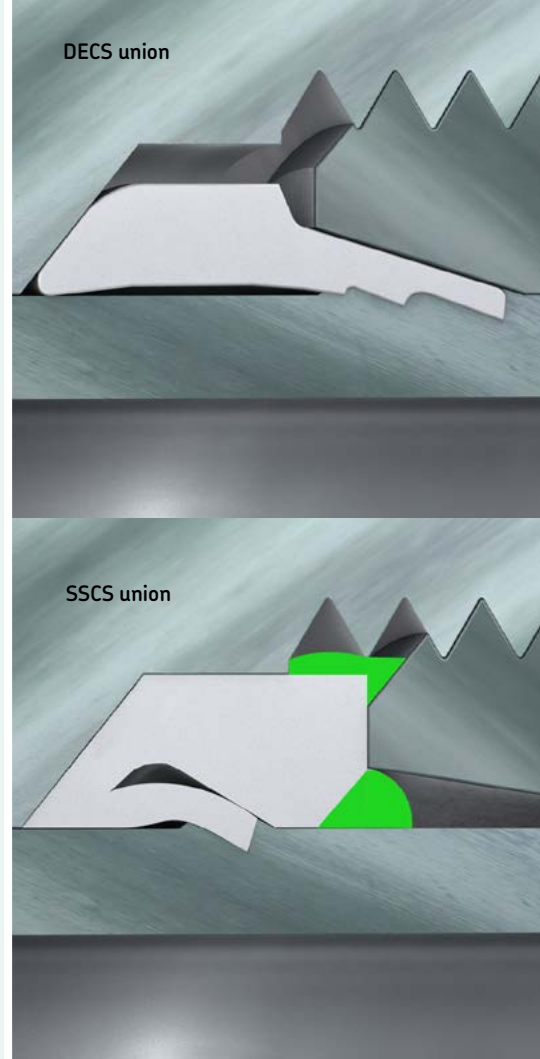
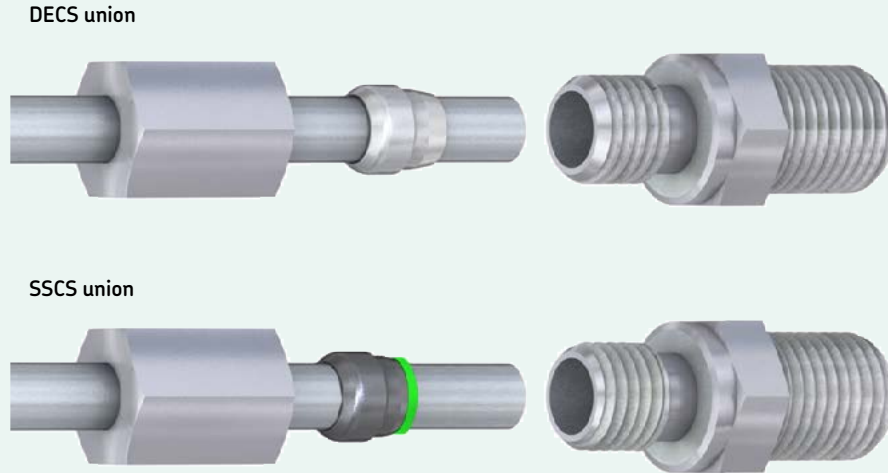

### Description

Solderless pipe fittings with cutting sleeves are designed for high-pressure oil, fluid grease and grease lubrication systems with pressures up to 400 bar and more with an operating temperature range from -25 to 80 °C. Depending on the operating pressure, the fittings are available in 3 pressure series: LL (very light), L (light) and S (heavy). The pipe connections, threads and pressure series are defined in DIN EN ISO 8434-1 (formerly DIN 2353).

In consideration of the application, the fittings are available in various materials (galvanized steel, stainless steel and brass).

Cutting sleeve fittings, also called bite-type fittings, are very popular due to simple assembly that requires only two wrenches. It is recognised for its high-pressure performance from a compact body. During assembly, the cutting ring forms, cutting edges into the tube that will remain after reassembly. The cutting ring can also be preassembled by a manual device or with the help of a tool.

### Types of cutting sleeve unions

- Double-edged cutting sleeve union (DECS)
- Soft-seal cutting sleeve union (SSCS)

### Series

	LL	L	S		
Design	very light	light	rigid		
Tube diameter (mm)	4, 6, 8, 10, 12	6, 8, 10, 12, 15	22, 26	6, 8, 10, 12	16, 20, 30
Nominal pressure	100 bar <i>1 450 psi</i>	315 bar <i>4 568 psi</i>	160 bar <i>2 320 psi</i>	630 bar <i>9 137 psi</i>	400 bar <i>5 800 psi</i>
Operation pressure max.	200 bar <i>2 900 psi</i>	500 bar <i>7 250 psi</i>	250 bar <i>3 625 psi</i>	900 bar <i>13 053 psi</i>	420 bar <i>6 090 psi</i>
Space requirement	very small	small	large		
Lubrication systems	medium-pressure lubrication systems		high-pressure grease systems		
Typical applications	vehicles, machine tools, wind mills		presses, injection molding machines, heavy industry		

# High-pressure cutting sleeve unions

## Overview of fitting types

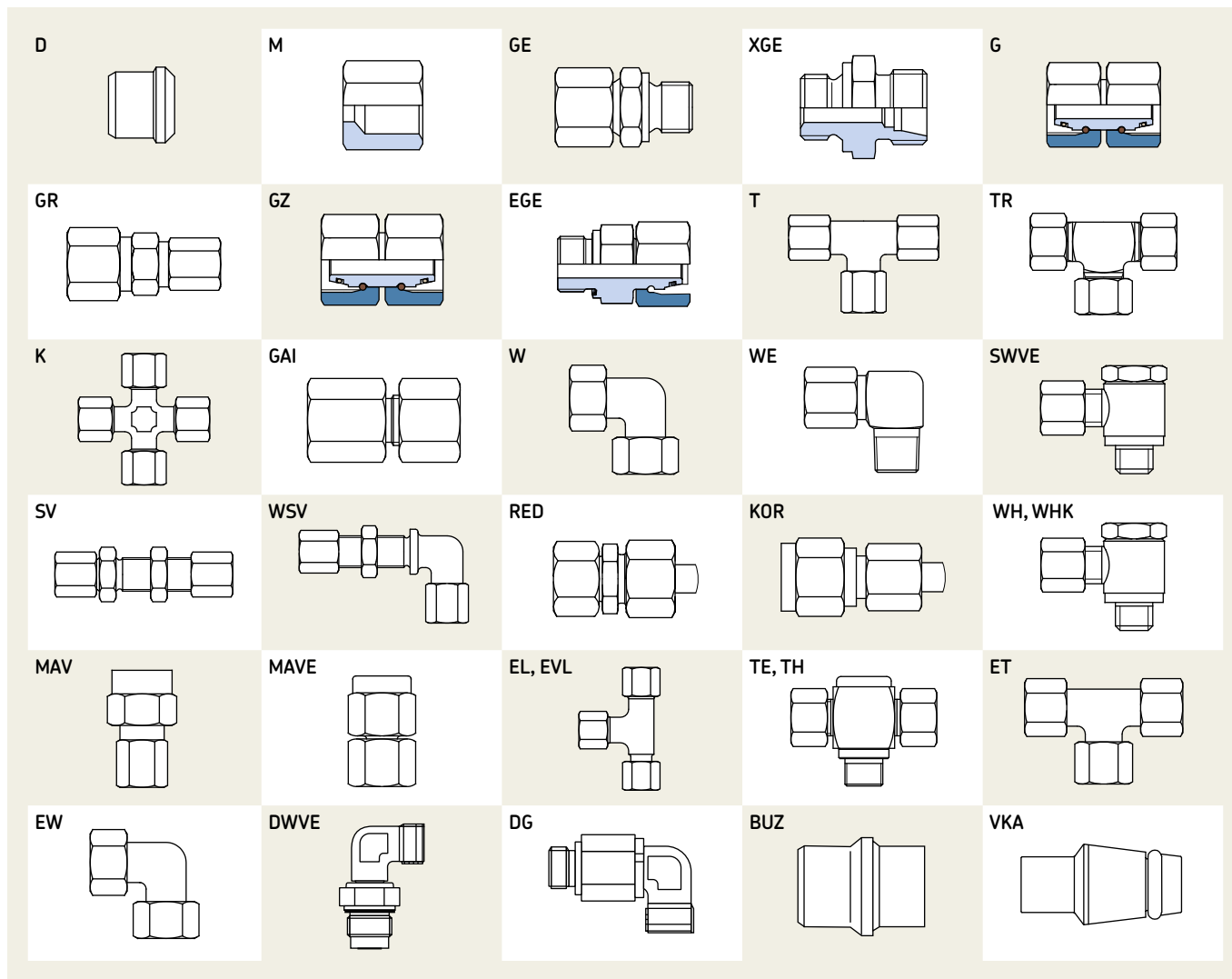

### Nomenclature of fitting designations

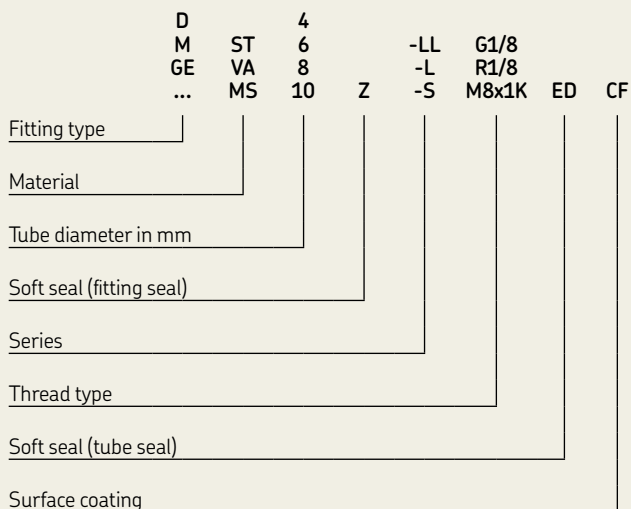

### Legend of fitting type abbreviations

- |  |  |
|--|--|
| <b>D</b> Cutting sleeve                            | <b>WHK</b> Banjo fitting consolidated  |
| <b>M</b> Union nuts                                | <b>MAV</b> Connectors for pressure gauge   |
| <b>GE</b> Straight screw-in connector              | <b>MAVE</b> Connectors for pressure gauge (adjustable)   |
| <b>XGE</b> Straight screw-in gland                 | <b>EL</b> L-connectors adjustable  |
| <b>G</b> Straight tube-to-tube connector           | <b>EVL</b> Standpipe branch tee  |
| <b>GR</b> Straight tube-to-tube reducing connector | <b>TE</b> Screw-in T-connector   |
| <b>GZ</b> Union stud                               | <b>TH</b> Screw-in T-connector (high-pressure)   |
| <b>EGE</b> Straight tube stud                      | <b>ET</b> Swivel nut branch tee  |
| <b>T</b> T-connector                               | <b>EW</b> Swivel nut elbow   |
| <b>TR</b> T-reducing connector                     | <b>DWVE</b> Elbow male stud plain bearing rotary union   |
| <b>K</b> K-connector                               | <b>DG</b> Elbow bulkhead ball bearing rotary union   |
| <b>GAI</b> Female connector straight               | <b>BUZ</b> Blanking plug for cones   |
| <b>W</b> Elbow connector                           | <b>VKA</b> Blanking plug for cones   |
| <b>WE</b> Elbow screw-in connector                 | <b>X</b> Prefix X means fitting without cutting sleeve and without union nut (example: GE and XGE) |
| <b>SWVE</b> Banjo fitting                          |  |
| <b>SV</b> Straight bulkhead connector              |  |
| <b>WSV</b> Elbow bulkhead connector                |  |
| <b>RED</b> Reducing connectors O-ring sealed       |  |
| <b>KOR</b> Reducing connectors                     |  |
| <b>WH</b> Banjo fitting (high-pressure)            |  |

## Double-edged cutting sleeve union (DECS)

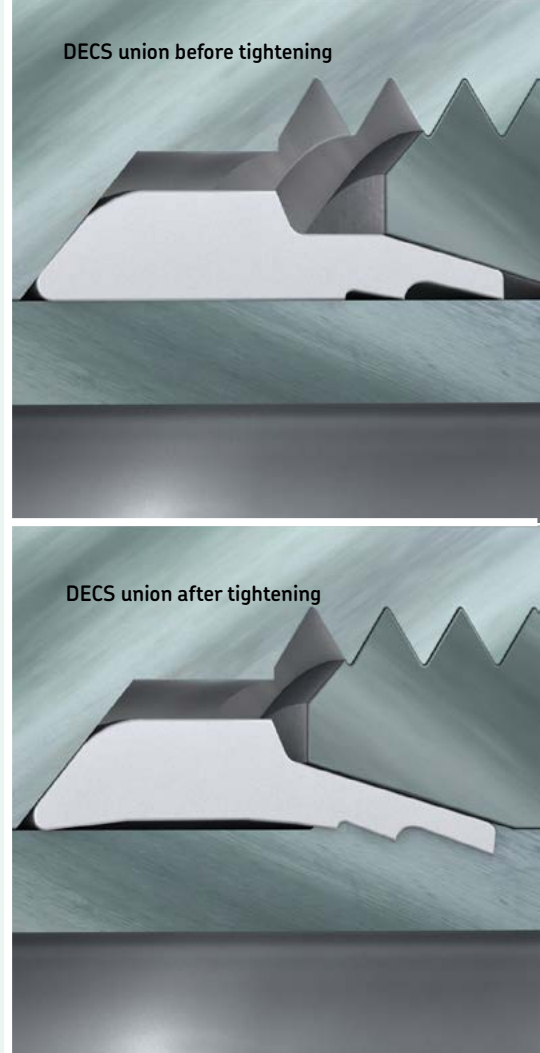
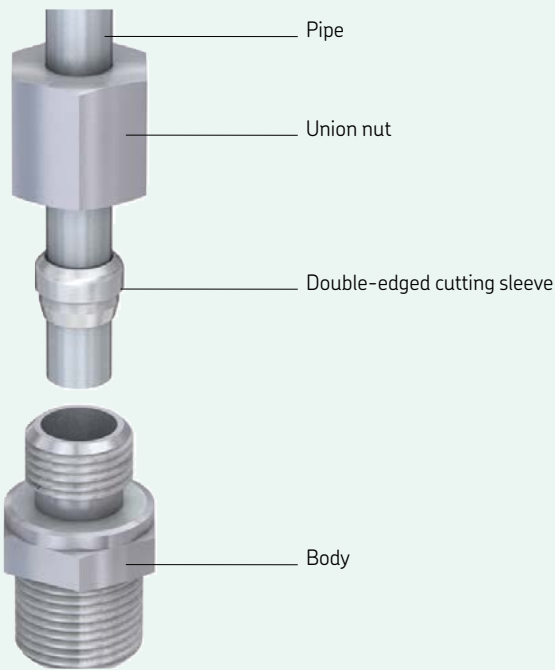

### Description

Double-edged cutting sleeve unions (DECS) consist of a union nut, a double-edged cutting sleeve and a body. To mount the union, the union nut and double-edged cutting sleeve must be placed on the pipe end. Both parts must be aligned as shown on the illustration above. Then the pipe can be pushed into the body before tightening the union nut. During this process, the double-edged cutting sleeve cuts into the pipe to seal the connection as shown in the illustration above.

The following must be considered when tightening the union:

- Manual presetting – tighten the nut by 1 1/4 turns
- Final assembly – 1/4 turn after perceptible rise in force

### Features and benefits

- Compact installation dimensions
- Virtually leakage-free, high-pressure union
- Recommended for high-pressure grease applications
- Suitable for thin and heavy pipes made from steel, stainless steel, copper and aluminum
- Common fitting system for high-pressure systems, especially for oil and grease lubrication
- Over-assembly protection through noticeable increase in force when tightening union nut
- Pipe vibration dampening resulting from pipe fixation during assembly (caused by DECS union)
- Wide operating temperature range from -25 to 80 °C



## Double-edged cutting sleeve unions

# Double-edged cutting sleeves D acc. to DIN 3861/ISO 8434-1

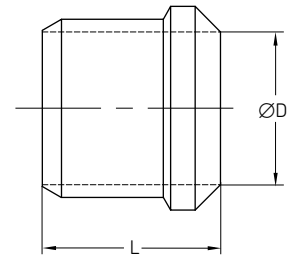

Order number	Designation	Series	Tube ØD	L	Material	Operating pressure max.		Weight	
						bar	psi	g	lb
			mm	mm					
Steel, galvanized									
223-14083-3	FERRULE ST D 4-LL	LL	4	6	Steel, galvanized	100	1 450	0,3	0.00
223-12295-2	FERRULE ST D 6-LL	LL	6	7	Steel, galvanized	100	1 450	0,8	0.00
223-12295-5	FERRULE ST D 8-LL	LL	8	7	Steel, galvanized	100	1 450	1	0.00
223-12295-9	FERRULE ST D 10-LL	LL	10	7	Steel, galvanized	100	1 450	1,3	0.00
223-12295-3	FERRULE ST D 6-L/S	L/S	6	9,5	Steel, galvanized	250	3 625	1	0.00
223-12295-6	FERRULE ST D 8-L/S	L/S	8	10	Steel, galvanized	250	3 625	1,7	0.00
223-12295-8	FERRULE ST D 10-L/S	L/S	10	10	Steel, galvanized	250	3 625	3,1	0.01
223-12296-1	FERRULE ST D 12-L/S	L/S	12	10,5	Steel, galvanized	250	3 625	3,5	0.01
223-12296-9	FERRULE ST D 15-L	L	15	10	Steel, galvanized	160	2 320	4,5	0.01
223-12583-1	FERRULE ST D 18-L	L	18	10,5	Steel, galvanized	160	2 320	5,5	0.01
223-12296-8	FERRULE ST D 16-S	S	16	10	Steel, galvanized	400	5 800	5,6	0.01
223-12296-3	FERRULE ST D 20-S	S	20	13	Steel, galvanized	400	5 800	11,4	0.03
223-12296-5	FERRULE ST D 30-S	S	30	13	Steel, galvanized	400	5 800	19,3	0.04
Stainless steel									
223-13639-5	FERRULE VA D 4-LL	LL	4	6	Stainless steel 1.4571	100	1 450	0,3	0.00
223-13639-3	FERRULE VA D 6-L/S	L/S	6	9,5	Stainless steel 1.4571	250	3 625	1	0.00
223-13639-2	FERRULE VA D 6-LL	LL	6	7	Stainless steel 1.4571	100	1 450	0,8	0.00
223-13639-1	FERRULE VA D 8-L/S	L/S	8	9,5	Stainless steel 1.4571	250	3 625	1,7	0.00
223-13639-4	FERRULE VA D 10-L/S	L/S	10	9,5	Stainless steel 1.4571	250	3 625	3,1	0.01
223-13639-9	FERRULE VA D 12-L/S	L/S	12	10	Stainless steel 1.4571	250	3 625	3,5	0.01
223-13639-7	FERRULE VA D 16-S	S	16	9,5	Stainless steel 1.4571	400	5 800	5,6	0.01
223-13639-8	FERRULE VA D 20-S	S	20	12,5	Stainless steel 1.4571	400	5 800	11,4	0.03
223-14092-5	FERRULE VA D 30-S	S	30	12,5	Stainless steel 1.4571	400	5 800	19,3	0.04
Zinc-nickel									
406-351	FERRULE ST D 6-LL Z3W	LL	6	7	Zinc-nickel	100	1 450	1	0.00
408-351	FERRULE ST D 8-LL Z3W	LL	8	7	Zinc-nickel	100	1 450	1	0.00
406-361	FERRULE ST D 6-L Z3W	L	6	11,5	Zinc-nickel	250	3 625	2	0.00
408-361	FERRULE ST D 8-L Z3W	L	8	11,5	zinc-nickel	250	3 625	2	0.00

## Double-edged cutting sleeve unions

# Union nuts M

## acc. to DIN 3861/ISO 8434-1

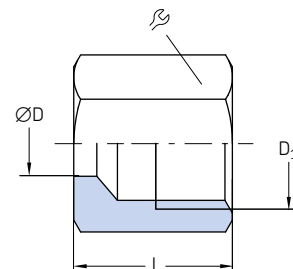

Order number	Designation	Series	Tube ØD	D <sub>1</sub>	L	⊳	Material	Operating pressure max.		Weight	
								bar	psi	g	lb
Steel, galvanized											
223-13032-1	COUPLING NUT ST M 4-LL CF	LL	4	M8×1	11	10	Steel, galvanized	100	1 450	4	0.01
223-12374-9	COUPLING NUT ST M 6-LL CF	LL	6	M10×1	12	12	Steel, galvanized	100	1 450	6	0.01
223-13032-3	COUPLING NUT ST M 8-LL CF	LL	8	M12×1	12	14	Steel, galvanized	100	1 450	7	0.02
223-12374-6	COUPLING NUT ST M 10-LL CF	LL	10	M14×1	12,5	17	Steel, galvanized	100	1 450	11	0.02
223-12373-9	COUPLING NUT ST M 6-L CF	L	6	M12×1,5	14,5	14	Steel, galvanized	250	3 625	10	0.02
223-13032-4	COUPLING NUT ST M 8-L CF	L	8	M14×1,5	14,5	17	Steel, galvanized	250	3 625	15	0.03
223-13032-6	COUPLING NUT ST M 10-L CF	L	10	M16×1,5	16	19	Steel, galvanized	250	3 625	18	0.04
223-12373-2	COUPLING NUT ST M 12-L CF	L	12	M18×1,5	16	22	Steel, galvanized	250	3 625	25	0.06
223-12374-8	COUPLING NUT ST M 15-L CF	L	15	M22×1,5	18	27	Steel, galvanized	250	3 625	42	0.09
223-12374-7	COUPLING NUT ST M 18-L CF	L	18	M26×1,5	18	32	Steel, galvanized	250	3 625	62	0.14
223-13032-9	COUPLING NUT ST M 16-S CF	S	16	M24×1,5	20,5	30	Steel, galvanized	400	5 800	66	0.15
223-12373-6	COUPLING NUT ST M 20-S CF	S	20	M30×2	24	36	Steel, galvanized	400	5 800	102	0.22
223-12374-2	COUPLING NUT ST M 30-S CF	S	30	M42×2	29	50	Steel, galvanized	400	5 800	219	0.48
Zinc-nickel											
406-352	COUPLING NUT ST M 6-LL Z3W	LL	6	M10×1	11,5	12	Zinc-nickel	100	1 450	5	0.01
408-352	COUPLING NUT ST M 8-LL Z3W	LL	8	M12×1	12	14	Zinc-nickel	100	1 450	5	0.01
406-362	COUPLING NUT ST M 6-L Z3W	L	6	M12×1,5	14,5	14	Zinc-nickel	250	3 625	30	0.07
408-362	COUPLING NUT ST M 8-L Z3W	L	8	M14×1,5	14,5	17	Zinc-nickel	250	3 625	35	0.08
Stainless steel											
223-13638-6	COUPLING NUT VA M 4-LL	LL	4	M8×1	11	10	Stainless steel 1.4571	100	1 450	4	0.01
223-13638-2	COUPLING NUT VA M 6-LL	LL	6	M10×1	12	12	Stainless steel 1.4571	100	1 450	6	0.01
223-14082-5	COUPLING NUT VA M 6-L	L	6	M12×1,5	14,5	14	Stainless steel 1.4571	250	3 625	10	0.02
223-13638-1	COUPLING NUT VA M 8-L	L	8	M14×1,5	14,5	17	Stainless steel 1.4571	250	3 625	15	0.03
223-13638-3	COUPLING NUT VA M 10-L	L	10	M16×1,5	16	19	Stainless steel 1.4571	250	3 625	18	0.04
223-14082-3	COUPLING NUT VA M 12-L	L	12	M18×1,5	16	22	Stainless steel 1.4571	250	3 625	25	0.06
223-13638-7	COUPLING NUT VA M 16-S	S	16	M24×1,5	20,5	30	Stainless steel 1.4571	400	5 800	66	0.15
223-13638-9	COUPLING NUT VA M 20-S	S	20	M30×2	24	36	Stainless steel 1.4571	400	5 800	102	0.22
223-14082-6	COUPLING NUT VA M 30-S	S	30	M42×2	29	50	Stainless steel 1.4571	400	5 800	219	0.48

## Double-edged cutting sleeve unions

# Straight screw-in connectors GE with metrical thread

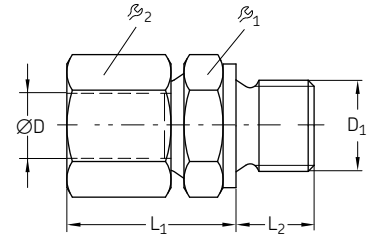

Order number	Designation	Series	Tube	D <sub>1</sub>	L <sub>1</sub>	L <sub>2</sub>	ϕ <sub>1</sub>	ϕ <sub>2</sub>	Material	Operating pressure max.		Weight			
			ØD							bar	psi	g	lb		
			mm	mm	mm	mm	mm	mm							
<b>Cylindrical thread</b>															
223-12571-2	TB.FITT.ST	GE 6-L	M10x1,0 CF	L	6	M10x1	23	8	14	14	Steel, galvanized	315	4 570	40	0.09
223-12361-6	TB.FITT.ST	GE 8-L	M12x1,5 CF	L	8	M12x1,5	25	12	17	17	Steel, galvanized	315	4 570	40	0.09
223-10263-8	TB.FITT.ST	GE10-L	M10x1,0 CF	L	10	M10x1	23	8	14	14	Steel, galvanized	315	4 570	40	0.09
223-14129-4	TB.FITT.ST	GE10-L	M14x1,5 CF	L	10	M14x1,5	26	12	19	19	Steel, galvanized	315	4 570	50	0.11
223-10313-2	TB.FITT.ST	GE10-L	M18x1,5 CF	L	10	M18x1,5	27	12	24	19	Steel, galvanized	315	4 570	71	0.16
412-423	TB.FITT.ST	GE12-L	M14x1,5 CF	L	12	M14x1,5	26	12	19	22	Steel, galvanized	315	4 570	60	0.13
412-403	TB.FITT.ST	GE12-L	M16x1,5 CF	L	12	M16x1,5	27	12	22	22	Steel, galvanized	315	4 570	70	0.15
412-433	TB.FITT.ST	GE12-L	M18x1,5 CF	L	12	M18x1,5	27	12	24	22	Steel, galvanized	315	4 570	77	0.17
415-403	TB.FITT.ST	GE15-L	M18x1,5 CF	L	15	M18x1,5	29	12	24	27	Steel, galvanized	250	3 626	97	0.21
415-413	TB.FITT.ST	GE15-L	M22x1,5 CF	L	15	M22x1,5	30	14	27	27	Steel, galvanized	250	3 626	100	0.22
418-403	TB.FITT.ST	GE18-L	M22x1,5 CF	L	18	M22x1,5	31	14	27	32	Steel, galvanized	250	3 626	143	0.32
223-14214-8	TB.FITT.ST	GE28-L	M33x2,0 CF	L	28	M33x2	34	18	41	41	Steel, galvanized	160	2 320	280	0.62
96-0335-0058	TB.FITT.ST	GE35-L	M42x2,0 CF	L	35	M42x2	39	20	50	50	Steel, galvanized	160	2 320	450	0.99
96-0342-0058	TB.FITT.ST	GE42-L	M48x2,0 CF	L	42	M48x2	42	22	55	60	Steel, galvanized	160	2 320	600	1.32
96-1206-0058	TB.FITT.ST	GE 6-S	M12x1,5K CF	S	6	M12x1,5	28	12	17	17	Steel, galvanized	800	11 600	30	0.07
408-413	TB.FITT.ST	GE 8-S	M14x1,5 CF	S	8	M14x1,5	30	12	19	17	Steel, galvanized	800	11 600	66	0.15
410-413	TB.FITT.ST	GE10-S	M16x1,5 CF	S	10	M16x1,5	31	12	22	22	Steel, galvanized	800	11 600	87	0.19
412-453	TB.FITT.ST	GE12-S	M18x1,5 CF	S	12	M18x1,5	33	12	24	24	Steel, galvanized	630	9 140	111	0.24
96-1214-0058	TB.FITT.ST	GE14-S	M20x1,5K CF	S	14	M20x1,5	37	14	27	17	Steel, galvanized	630	9 140	140	0.31
<b>Tapered thread</b>															
223-12533-5	TB.FITT.ST	GE 4-LL	M6x1 K CF	LL	4	M6x1 tap.	26	8	9	10	Steel, galvanized	100	1 450	12	0.03
223-12271-8	TB.FITT.ST	GE 4-LL	M8x1 K CF	LL	4	M8x1 tap.	26	8	10	10	Steel, galvanized	100	1 450	15	0.03
223-13069-1	TB.FITT.ST	GE 4-LL	M10x1 K CF	LL	4	M10x1 tap.	26	8	10	10	Steel, galvanized	100	1 450	16	0.04
223-12533-9	TB.FITT.ST	GE 6-LL	M6x1 K CF	LL	6	M6x1 tap.	26	8	11	12	Steel, galvanized	100	1 450	19	0.04
223-13023-1	TB.FITT.ST	GE 6-LL	M8x1 K CF	LL	6	M8x1 tap.	26	8	11	12	Steel, galvanized	100	1 450	20	0.04
223-12271-7	TB.FITT.ST	GE 6-LL	M10x1 K CF	LL	6	M10x1 tap.	26	8	11	12	Steel, galvanized	100	1 450	21	0.05
223-13021-1	TB.FITT.ST	GE 8-LL	M10x1,0K CF	LL	8	M10x1 tap.	28	8	12	14	Steel, galvanized	100	1 450	24	0.05
410-443	TB.FITT.ST	GE10-L	M10x1,0K CF	L	10	M10x1 tap.	25	9	19	17	Steel, galvanized	500	7 250	56	0.12
223-13658-7	TB.FITT.VA	GE 6-LL	M 6x1 K	LL	6	M6x1 tap.	26	8	11	12	Stainless steel 1.4571	100	1 450	26	0.06
223-13658-6	TB.FITT.VA	GE 6-LL	M 8x1 K	LL	6	M8x1 tap.	26	8	11	12	Stainless steel 1.4571	100	1 450	27	0.06
223-13658-5	TB.FITT.VA	GE 6-LL	M 10x1 K	LL	6	M10x1 tap.	26	8	11	12	Stainless steel 1.4571	100	1 450	31	0.07
223-13715-1	TB.FITT.VA	GE 8-LL	M 10x1 K	LL	8	M10x1 tap.	28	8	12	14	Stainless steel 1.4571	100	1 450	33	0.07
223-14184-5	TB.FITT.VA	GE 6-L	M 10x1 K	L	6	M10x1 tap.	23	8	14	14	Stainless steel 1.4571	100	1 450	31	0.07
410-403-S3	TB.FITT.VA	GE10-L	M14x1,5K	L	10	M14x1,5 tap.	26	12	19	19	Stainless steel 1.4571	315	4 570	24	0.05

## Double-edged cutting sleeve unions

## Straight screw-in connectors GE with Whitworth pipe thread

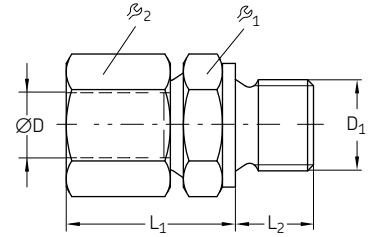

Order number	Designation	Series	Tube ØD	D <sub>1</sub>	L <sub>1</sub>	L <sub>2</sub>	r <sub>1</sub>	r <sub>2</sub>	Material	Operating pressure max.		Weight	
			mm	in	mm	mm	mm	mm		bar	psi	g	lb
Cylindrical thread													
223-13016-3	FITTING ST GE 6-L G 1/8 A CF	L	6	G 1/8 A	23	8	14	14	Steel, galvanized	315	4 570	18	0.04
223-12477-8	FITTING ST GE 6-L G 1/4 A CF	L	6	G 1/4 A	25	12	19	14	Steel, galvanized	315	4 570	35	0.08
223-13766-6	FITTING ST GE 6-L G 3/8 A CF	L	6	G 3/8 A	26	12	22	14	Steel, galvanized	315	4 570	51	0.11
223-10814-2	FITTING ST GE 8-L G 1/8 A CF	L	8	G 1/8 A	23	8	14	17	Steel, galvanized	315	4 570	24	0.05
223-12477-6	FITTING ST GE 8-L G 1/4 A CF	L	8	G 1/4 A	25	12	19	17	Steel, galvanized	315	4 570	35	0.08
223-10080-3	FITTING ST GE 8-L G 3/8 A CF	L	8	G 3/8 A	26	12	22	17	Steel, galvanized	315	4 570	53	0.12
408-453W	FITTING ST GE 8-L G 1/2 A CF	L	8	G 1/2 A	27	14	27	17	Steel, galvanized	315	4 570	82	0.18
223-12272-9	FITTING ST GE 10-L G 1/4 A CF	L	10	G 1/4 A	26	12	19	19	Steel, galvanized	315	4 570	41	0.09
223-14214-4	FITTING ST GE 10-L G 3/8 A CF	L	10	G 3/8 A	27	12	22	19	Steel, galvanized	315	4 570	55	0.12
223-10313-7	FITTING ST GE 10-L G 1/2 A CF	L	10	G 1/2 A	28	14	27	19	Steel, galvanized	315	4 570	83	0.18
223-12477-9	FITTING ST GE 12-L G 1/4 A CF	L	12	G 1/4 A	27	12	19	22	Steel, galvanized	315	4 570	46	0.10
223-12360-8	FITTING ST GE 12-L G 3/8 A CF	L	12	G 3/8 A	27	12	22	22	Steel, galvanized	315	4 570	56	0.12
412-453W	FITTING ST GE 12-L G 1/2 A CF	L	12	G 1/2 A	28	14	27	22	Steel, galvanized	250	3 625	79	0.17
415-443W	FITTING ST GE 15-L G 3/4 A CF	L	15	G 3/4 A	30	16	32	27	Steel, galvanized	250	3 625	163	0.36
223-12361-9	FITTING ST GE 15-L G 1/2 A CF	L	15	G 1/2 A	29	14	27	27	Steel, galvanized	250	3 625	119	0.26
223-13621-8	FITTING ST GE 15-L G 3/8 A CF	L	15	G 3/8 A	29	12	24	27	Steel, galvanized	250	3 625	101	0.22
223-13766-1	FITTING ST GE 18-L G 1/2 A CF	L	18	G 1/2 A	31	14	27	32	Steel, galvanized	250	3 625	139	0.31
418-413W	FITTING ST GE 18-L G 3/4 A CF	L	18	G 3/4 A	30	16	32	32	Steel, galvanized	250	3 625	178	0.39
223-13749-3	FITTING ST GE 22-L G 1/2 A CF	L	22	G 1/2 A	33	14	32	36	Steel, galvanized	160	2 320	180	0.40
223-13016-2	FITTING ST GE 22-L G 3/4 A CF	L	22	G 3/4 A	33	16	32	36	Steel, galvanized	160	2 320	191	0.42
223-14214-9	FITTING ST GE 28-L G 3/4 A CF	L	28	G 3/4 A	34	16	41	41	Steel, galvanized	160	2 320	257	0.57
223-13610-9	FITTING ST GE 28-L G 1 A CF	L	28	G 1 A	34	18	41	41	Steel, galvanized	160	2 320	287	0.63
223-12477-1	FITTING ST GE 6-S G 1/4 A CF	S	6	G 1/4 A	28	12	19	17	Steel, galvanized	400	5 800	54	0.12
223-12477-2	FITTING ST GE 8-S G 1/4 A CF	S	8	G 1/4 A	30	12	19	19	Steel, galvanized	400	5 800	60	0.13
223-13016-6	FITTING ST GE 8-S G 3/8 A CF	S	8	G 3/8 A	30	12	22	19	Steel, galvanized	400	5 800	78	0.17
223-13016-9	FITTING ST GE 10-S G 1/4 A CF	S	10	G 1/4 A	31	12	19	22	Steel, galvanized	400	5 800	77	0.17
223-13016-4	FITTING ST GE 10-S G 3/8 A CF	S	10	G 3/8 A	31	12	22	22	Steel, galvanized	400	5 800	90	0.20
223-13016-7	FITTING ST GE 12-S G 3/8 A CF	S	12	G 3/8 A	33	12	22	24	Steel, galvanized	400	5 800	96	0.21
223-14129-3	FITTING ST GE 12-S G 1/2 A CF	S	12	G 1/2 A	24	14	27	24	Steel, galvanized	400	5 800	91	0.20
96-1114-0058	FITTING ST GE 14-S G 1/2 A CF	S	14	G 1/2 A	27	14	27	27	Steel, galvanized	400	5 800	153	0.34
223-13749-5	FITTING ST GE 16-S G 3/8 A CF	S	16	G 3/8 A	36	12	27	30	Steel, galvanized	400	5 800	165	0.36
223-13621-1	FITTING ST GE 16-S G 1/2 A CF	S	16	G 1/2 A	37	14	27	30	Steel, galvanized	400	5 800	164	0.36
223-12360-6	FITTING ST GE 20-S G 1/2 A CF	S	20	G 1/2 A	42	14	32	36	Steel, galvanized	400	5 800	214	0.47
223-12359-6	FITTING ST GE 20-S G 3/4 A CF	S	20	G 3/4 A	42	16	32	32	Steel, galvanized	400	5 800	224	0.49
Tapered thread													
223-12270-8	FITTING ST GE 4-LL R 1/8K CF	LL	4	R 1/8	26	8	11	10	Steel, galvanized	100 <sup>1)</sup>	1 450 <sup>1)</sup>	12	0.03
223-12270-7	FITTING ST GE 6-LL R 1/8K CF	LL	6	R 1/8	26	8	11	12	Steel, galvanized	100 <sup>1)</sup>	1 450 <sup>1)</sup>	15	0.03
223-12270-9	FITTING ST GE 8-LL R 1/8K CF	LL	8	R 1/8	28	8	12	14	Steel, galvanized	100 <sup>1)</sup>	1 450 <sup>1)</sup>	18	0.04
223-13621-6	FITTING ST GE 8-LL R 1/4K CF	LL	8	R 1/4	32	12	14	14	Steel, galvanized	100 <sup>1)</sup>	1 450 <sup>1)</sup>	26	0.06
96-5911-0058	FITTING ST GE10-LL R 1/4K CF	LL	10	R 1/4	32	12	14	17	Steel, galvanized	100 <sup>1)</sup>	1 450 <sup>1)</sup>	36	0.08
96-5912-0058	FITTING ST GE12-LL R 1/8K CF	LL	12	R 1/8	32	12	17	19	Steel, galvanized	100 <sup>1)</sup>	1 450 <sup>1)</sup>	65	0.14
96-5913-0058	FITTING ST GE12-LL R 3/8K CF	LL	12	R 3/8	32	12	17	19	Steel, galvanized	100 <sup>1)</sup>	1 450 <sup>1)</sup>	55	0.12
410-443W	FITTING ST GE10-L R 1/8K CF	L	10	R 1/8	34	8	14	17	Steel, galvanized	315	4 570	42	0.09

<sup>1)</sup> In grease lubrication systems fittings are permitted for operating pressures up to 350 bar, 5080 psi

## Double-edged cutting sleeve unions

# Straight screw-in connectors GE with Whitworth pipe thread, made from stainless steel or brass

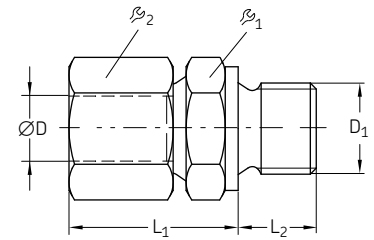

Order number	Designation	Series	Tube	D <sub>1</sub>		L <sub>1</sub>	L <sub>2</sub>	β <sub>1</sub>	β <sub>2</sub>	Material	Operating pressure max.		Weight	
				mm	in						bar	psi	g	lb
<b>Stainless steel</b>														
223-13614-9	TB.FITT.VA GE 6-LL R 1/8K	LL	6	R 1/8		26	8	11	10	Stainless steel	100	1 450	65	0.14
223-13658-2	TB.FITT.VA GE 6-L G 1/8A	L	6	G 1/8A		23	8	14	14	Stainless steel	315	4 570	23	0.05
223-13658-9	TB.FITT.VA GE 6-L G 1/4A	L	6	G 1/4A		25	12	19	14	Stainless steel	315	4 570	40	0.09
223-13658-1	TB.FITT.VA GE 8-LL G 1/8A	LL	8	G 1/8A		24	8	14	17	Stainless steel	315	4 570	33	0.07
223-14420-7	TB.FITT.VA GE10-L G 1/4A	L	10	G 1/4A		26	12	19	19	Stainless steel	315	4 570	50	0.11
223-13715-9	TB.FITT.VA GE15-L G 1/2A	L	15	G 1/2A		29	14	27	27	Stainless steel	250	3 625	119	0.26
223-13715-6	TB.FITT.VA GE15-L G 3/8A	L	15	G 3/8A		29	12	24	27	Stainless steel	250	3 625	88	0.19
223-14420-8	TB.FITT.VA GE18-L G 1/2A	L	18	G 1/2A		31	14	27	32	Stainless steel	250	3 625	139	0.31
99-0222-0058	TB.FITT.VA GE22-L G 3/4A	L	22	G 3/4A		33	16	32	36	Stainless steel	160	2 320	191	0.42
223-14184-2	TB.FITT.VA GE28-L G 1A	L	28	G 1A		34	18	41	41	Stainless steel	160	2 320	278	0.61
223-13614-7	TB.FITT.VA GE 6-S G 1/4A	S	6	G 1/4A		28	12	19	17	Stainless steel	400	5 800	54	0.12
223-13614-6	TB.FITT.VA GE 8-S G 1/4A	S	8	G 1/4A		30	12	19	19	Stainless steel	400	5 800	64	0.14
223-12452-9	TB.FITT.VA GE10-S G 1/4A	S	10	G 1/4A		31	12	19	22	Stainless steel	400	5 800	77	0.17
223-12452-7	TB.FITT.VA GE16-S G 1/2A	S	16	G 1/2A		37	14	27	30	Stainless steel	400	5 800	164	0.36
223-13658-4	TB.FITT.VA GE20-S G 1/2A	S	20	G 1/2A		42	14	32	36	Stainless steel	400	5 800	214	0.47
223-12452-5	TB.FITT.VA GE20-S G 3/4A	S	20	G 3/4A		42	16	32	32	Stainless steel	400	5 800	224	0.49
<b>Brass</b>														
223-12377-7	TB.FITT.MS GE 8-L G 1/4A	L	8	G 1/4A		25	12	19	17	Brass	200	2 900	26	0.06
223-12377-8	TB.FITT.MS GE15-L G 1/2A	L	15	G 1/2A		29	14	27	27	Brass	160	2 320	72	0.16

# Straight screw-in connectors GE with NPT pipe thread

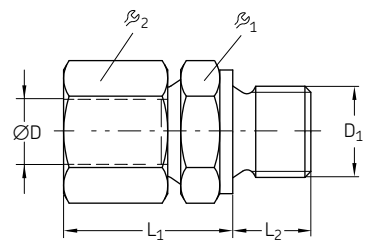

Order number	Designation	Series	Tube	D <sub>1</sub>		L <sub>1</sub>	L <sub>2</sub>	β <sub>1</sub>	β <sub>2</sub>	Material	Operating pressure max.		Weight	
				mm	in						bar	psi	g	lb
<b>Cylindrical thread</b>														
223-14214-2	FITTING ST GE 6-L 1/8NPT CF	L	6	1/8 NPT		32	10	11	12	Steel, galvanized	100	1 450	24	0.05
223-12273-5	FITTING ST GE 8-L 1/4NPT CF	L	8	1/4 NPT		38	14.5	17	17	Steel, galvanized	315	4 570	42	0.09
223-13096-2	FITTING ST GE 10-S 1/4NPT CF	S	10	1/4 NPT		44	14.5	19	22	Steel, galvanized	630	9 140	77	0.17
223-14214-5	FITTING ST GE 20-S 1/2NPT CF	S	20	1/2 NPT		59	19.5	32	36	Steel, galvanized	400	5 800	235	0.52

## Double-edged cutting sleeve unions

## Straight screw-in glands XGE

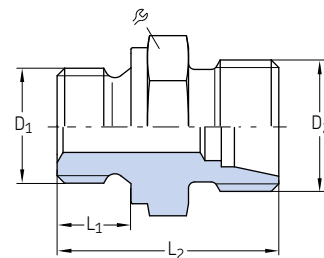

Order number	Designation	Series	Tube Ø	D <sub>1</sub>	D <sub>2</sub>	L <sub>1</sub>	L <sub>2</sub>	Material	Operating pressure max.		Weight		
				mm	mm	mm	mm		mm	bar	psi	g	lb
223-13766-9	TB.FITT.ST XGE 6-LL M 10x1,0K CF	LL	6	M10x1 tap.	M10x1	8	20	11	Steel, galv.	100	1 450	17	0.04
223-14129-1	TB.FITT.ST XGE 6-LL M 8x1,0K CF	LL	6	M8x1 tap.	M10x1	8	20	11	Steel, galv.	100	1 450	17	0.04
223-14129-2	TB.FITT.ST XGE 6-LL R 1/8K CF	LL	6	R 1/8	M12x1,5	8	20	11	Steel, galv.	100	1 450	18	0.04
223-14234-7	TB.FITT.ST XGE 6-L M 10x1,0 CF	L	6	M10x1	M12x1,5	8	23,5	14	Steel, galv.	500	7 250	20	0.04
408-313	TB.FITT.ST XGE 8-L M 14x1,5 CF	L	8	M14x1,5	M14x1,5	9	36	17	Steel, galv.	500	7 250	31	0.07
410-313	TB.FITT.ST XGE10-L M 16x1,5 CF	L	10	M16x1,5	M16x1,5	9	31,5	22	Steel, galv.	500	7 250	40	0.09
223-14304-2	TB.FITT.ST XGE 10-L M 14x1,5 CF	L	10	M14x1,5	M16x1,5	9	30,0	19	Steel, galv.	500	7 250	40	0.09
223-14304-7	TB.FITT.ST XGE 12-L M 14x1,5 CF	L	12	M14x1,5	M18x1,5	12	30,0	19	Steel, galv.	400	5 800	55	0.12
223-13610-8	TB.FITT.ST XGE 18-L M 22x1,5 CF	L	18	M22x1,5	M26x1,5	14	36,0	27	Steel, galv.	315	4 570	148	0.33
223-11229-9	TB.FITT.ST XGE 8-L G 1/4A CF	L	8	G 1/4A	M14x1,5	12	30	19	Steel, galv.	500	7 250	35	0.08
223-14234-4	TB.FITT.ST XGE10-L G 1/8A CF	L	10	G 1/8A	M18x1,5	12	34	17	Steel, galv.	500	7 250	33	0.07
223-10055-9	TB.FITT.ST XGE10-L G 3/8A CF	L	10	G 3/8A	M18x1,5	12	31,5	22	Steel, galv.	500	7 250	55	0.12
223-14418-7	TB.FITT.ST XGE18-L G 1/2A CF	L	18	G 1/2A	M26x1,5	14	36	27	Steel, galv.	400	5 800	139	0.31
223-11089-3	TB.FITT.ST XGE10-S G 1/4A CF	S	10	G 1/4A	M18x1,5	12	30	19	Steel, galv.	800	11 600	41	0.09
223-14304-5	TB.FITT.ST XGE20-S G 1/2A CF	S	20	G 1/2A	M30x2	14	45	32	Steel, galv.	420	6 090	262	0.58

## Straight tube-to-tube connectors G

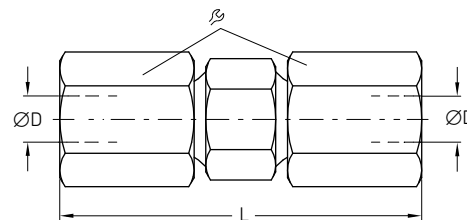

Order number	Designation	Series	Tube ØD	L	Material	Operating pressure max.		Weight		
						bar	psi	g	lb	
Steel, galvanized										
223-12531-8	TB.FITT.ST G 4-LL CF	LL	4	31	10	Steel, galvanized	100	1 450	13	0.03
223-12482-9	TB.FITT.ST G 6-LL CF	LL	6	32	12	Steel, galvanized	100	1 450	21	0.05
223-12531-9	TB.FITT.ST G 8-LL CF	LL	8	35	14	Steel, galvanized	100	1 450	26	0.06
223-12531-2	TB.FITT.ST G 10-L CF	L	10	42	19	Steel, galvanized	500	7 250	65	0.14
223-13732-8	TB.FITT.ST G 12-L CF	L	12	43	22	Steel, galvanized	500	7 250	84	0.19
223-12531-6	TB.FITT.ST G 15-L CF	L	15	46	27	Steel, galvanized	400	5 800	145	0.32
223-13732-4	TB.FITT.ST G 18-L CF	L	18	48	32	Steel, galvanized	400	5 800	205	0.45
223-13049-3	TB.FITT.ST G 10-S CF	S	10	49	22	Steel, galvanized	800	11 600	112	0.25
223-12531-4	TB.FITT.ST G 16-S CF	S	16	57	30	Steel, galvanized	630	9 140	234	0.52
223-12363-2	TB.FITT.ST G 20-S CF	S	20	66	36	Steel, galvanized	420	6 090	369	0.81
223-12363-6	TB.FITT.ST G 30-S CF	S	30	80	50	Steel, galvanized	420	6 090	806	1.78
Stainless steel										
223-13615-5	TB.FITT.VA G 6-L	L	6	39	14	Stainless steel 1.4571	315	4 570	36	0.08
223-13615-3	TB.FITT.VA G 8-L	L	8	40	17	Stainless steel 1.4571	315	4 570	50	0.11
223-13615-6	TB.FITT.VA G 10-L	L	10	42	19	Stainless steel 1.4571	315	4 570	37	0.08
223-12454-8	TB.FITT.VA G 15-L	L	15	46	27	Stainless steel 1.4571	315	4 570	145	0.32
223-12454-1	TB.FITT.VA G 10-S	S	10	49	22	Stainless steel 1.4571	630	9 140	112	0.25
223-12454-6	TB.FITT.VA G 16-S	S	16	57	30	Stainless steel 1.4571	400	5 800	234	0.52
223-12454-3	TB.FITT.VA G 20-S	S	20	66	36	Stainless steel 1.4571	400	5 800	369	0.81
223-12454-5	TB.FITT.VA G 30-S	S	30	80	50	Stainless steel 1.4571	400	5 800	806	1.78

## Double-edged cutting sleeve unions

# Straight tube-to-tube reducing connectors GR

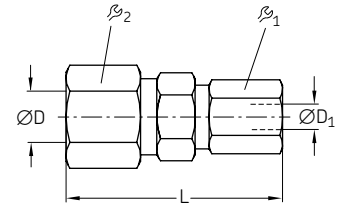

Order number	Designation	Series	Tube	Tube	L	$\varnothing_1$	$\varnothing_2$	Material	Operating pressure max.		Weight		
			$\varnothing D$	$\varnothing D_1$		mm	mm		bar	psi	g	lb	
			mm	mm	mm	mm	mm						
Steel, galvanized													
223-12542-2	TB.FITT.ST GR 6/4-LL CF	LL	6	4	32	10	12	Steel, galvanized	100	1450	7	0.02	
504-412	TB.FITT.ST GR 8/4-LL CF	LL	8	4	34	10	14	Steel, galvanized	100	1450	9	0.02	
223-13705-5	TB.FITT.ST GR 8/6-L CF	L	8	6	40	14	17	Steel, galvanized	500	7250	16	0.04	
223-13622-3	TB.FITT.ST GR 10/6-L CF	L	10	6	41	14	19	Steel, galvanized	500	7250	21	0.05	
223-13024-4	TB.FITT.ST GR 10/8-L CF	L	10	8	41	17	19	Steel, galvanized	500	7250	21	0.05	
223-10986-1	TB.FITT.ST GR 12/6-L CF	L	12	6	42	14	22	Steel, galvanized	400	5800	26	0.06	
223-13622-7	TB.FITT.ST GR 12/8-L CF	L	12	8	42	17	22	Steel, galvanized	400	5800	26	0.06	
510-410	TB.FITT.ST GR 12/10-L CF	L	12	10	43	19	22	Steel, galvanized	400	5800	29	0.06	
223-13024-8	TB.FITT.ST GR 15/8-L CF	L	15	8	45	17	27	Steel, galvanized	400	5800	42	0.09	
223-12542-7	TB.FITT.ST GR 15/10-L CF	L	15	10	45	19	27	Steel, galvanized	400	5800	46	0.10	
223-12542-8	TB.FITT.ST GR 15/12-L CF	L	15	12	45	22	27	Steel, galvanized	400	5800	45	0.10	
510-413	TB.FITT.ST GR 18/10-L CF	L	18	10	46	19	32	Steel, galvanized	400	5800	65	0.14	
512-412	TB.FITT.ST GR 18/12-L CF	L	18	12	46	22	32	Steel, galvanized	400	5800	64	0.14	
515-410	TB.FITT.ST GR 18/15-L CF	L	18	15	48	27	32	Steel, galvanized	400	5800	65	0.14	
223-13622-1	TB.FITT.ST GR 16/10-S CF	S	16	10	54	22	30	Steel, galvanized	630	9140	80	0.18	
223-12364-4	TB.FITT.ST GR 20/10-S CF	S	20	10	60	22	36	Steel, galvanized	420	6090	129	0.28	
223-13024-1	TB.FITT.ST GR 30/20-S CF	S	30	20	74	36	50	Steel, galvanized	420	6090	299	0.66	
Stainless steel													
223-13619-9	TB.FITT.VA GR 16/10 S	S	16	10	54	22	30	Stainless steel 1.4571	400	5800	80	0.18	
223-13619-2	TB.FITT.VA GR 20/10 S	S	20	10	60	22	36	Stainless steel 1.4571	400	5800	129	0.28	
223-13791-5	TB.FITT.VA GR 30/20 S	S	30	20	74	36	50	Stainless steel 1.4571	400	5800	299	0.66	

## Double-edged cutting sleeve unions

## Union studs GZ

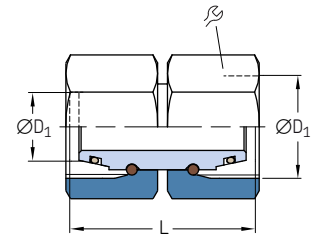

Order number	Designation	Series	Tube ØD <sub>1</sub>		L	β	Material	Operating pressure max.		Weight	
			mm	mm				bar	psi	g	lb
Steel, galvanized											
223-10550-2	TB.STUD ST GZ 6-L CF	L	6	M14×1,5	33	14	Steel, galvanized	500	7 250	28	0.06
223-10550-8	TB.STUD ST GZ 8-L CF	L	8	M14×1,5	33	17	Steel, galvanized	500	7 250	41	0.09
223-14253-2	TB.STUD ST GZ10-L CF	L	10	M16×1,5	34	19	Steel, galvanized	500	7 250	53	0.12
223-10550-6	TB.STUD ST GZ12-L CF	L	12	M18×1,5	34	22	Steel, galvanized	400	5 800	71	0.16
223-14253-5	TB.STUD ST GZ15-L CF	L	15	M22×1,5	39	27	Steel, galvanized	400	5 800	129	0.28
223-10550-1	TB.STUD ST GZ 6-S CF	S	6	M14×1,5	33	17	Steel, galvanized	800	11 600	41	0.09
223-14253-4	TB.STUD ST GZ10-S CF	S	10	M18×1,5	35	22	Steel, galvanized	800	11 600	74	0.16
223-14253-1	TB.STUD ST GZ16-S CF	S	16	M24×1,5	42	30	Steel, galvanized	630	9 140	172	0.38
223-14497-8	TB.STUD ST GZ20-S CF	S	20	M30×2	48	36	Steel, galvanized	420	6 090	261	0.58
223-14253-3	TB.STUD ST GZ30-S CF	S	30	M42×2	62	50	Steel, galvanized	420	6 090	605	1.33
Stainless steel											
223-14497-1	TB.STUD VA GZ10-L	L	10	M16×1,5	34	19	Stainless steel 1.4571	315	4 570	53	0.12
223-14497-4	TB.STUD VA GZ20-S	S	20	M30×2	48	36	Stainless steel 1.4571	400	5 800	261	0.58

## Straight tube studs EGE

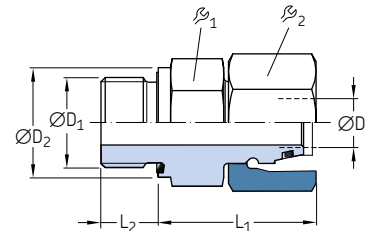

Order number	Designation	Series	Tube ØD <sub>1</sub>		ØD <sub>2</sub>	L <sub>1</sub>	L <sub>2</sub>	β <sub>1</sub>	β <sub>2</sub>	Material	Operating pressure max.		Weight	
			mm	mm							mm	mm	mm	mm
223-14130-7	TB.STUD ST EGE 6-L G 1/8A-ED CF	L	6	G 1/8A	14	24,5	8	14	14	Steel, galv.	500	7 250	27	0.06
223-13686-1	TB.STUD ST EGE10-L G 1/4A-ED CF	L	10	G 1/4A	19	27,5	12	19	19	Steel, galv.	500	7 250	54	0.12
223-14130-9	TB.STUD ST EGE10-L G 3/8A-ED CF	L	10	G 3/8A	22	29	12	22	19	Steel, galv.	400	5 800	70	0.15
223-14187-4	TB.STUD ST EGE10-S G 3/8A-ED CF	S	10	G 3/8A	19	27,5	12	19	19	Steel, galv.	315	4 570	44	0.10
223-14187-7	TB.STUD ST EGE10-L 1/4 NPT CF	L	10	1/4 NPT	19	27,5	12	19	19	Steel, galv.	315	4 570	44	0.10
223-10563-8	TB.STUD ST EGE12-L M16×1,5-ED CF	L	12	M16×1,5	22	30,5	12	22	22	Steel, galv.	400	5 800	67	0.15
223-10563-5	TB.STUD ST EGE12-L G 1/4A-ED CF	L	12	G 1/4A	19	27,5	12	19	22	Steel, galv.	400	5 800	61	0.13
223-10563-7	TB.STUD ST EGE 6-S G 1/4A-ED CF	S	6	G 1/4A	19	27	12	19	17	Steel, galv.	800	11 600	53	0.12
223-10563-6	TB.STUD ST EGE12-S G 3/8A-ED CF	S	12	G 3/8A	22	34	12	22	24	Steel, galv.	630	9 140	95	0.21
223-14130-2	TB.STUD ST EGE30-S 3/4 NPT-ED CF	S	20	3/4 NPT	32	43	16	32	36	Steel, galv.	400	5 800	254	0.56



## Double-edged cutting sleeve unions

### T-connectors T

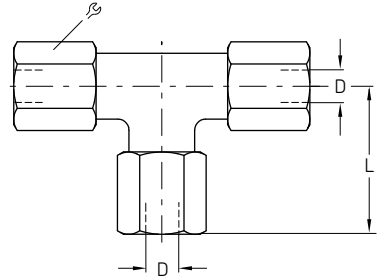

Order number	Designation	Series	Tube ØD	L	β	Material	Operating pressure max.		Weight	
							bar	psi	g	lb
			mm	mm	mm					
Steel, galvanized										
223-12563-5	TB.FITT.ST T 4-LL CF	LL	4	21	10	Steel, galvanized	100	1 450	31	0.07
223-12484-2	TB.FITT.ST T 6-L CF	L	6	27	14	Steel, galvanized	500	7 250	58	0.13
223-12484-6	TB.FITT.ST T 8-L CF	L	8	29	17	Steel, galvanized	500	7 250	104	0.23
223-13057-5	TB.FITT.ST T10-L CF	L	10	30	19	Steel, galvanized	500	7 250	111	0.24
412-407	TB.FITT.ST T12-L CF	L	12	32	22	Steel, galvanized	400	5 800	149	0.33
223-12563-2	TB.FITT.ST T15-L CF	L	15	36	27	Steel, galvanized	400	5 800	247	0.54
418-407	TB.FITT.ST T18-L CF	L	18	40	32	Steel, galvanized	400	5 800	383	0.84
223-13057-4	TB.FITT.ST T22-L CF	L	22	44	36	Steel, galvanized	250	3 625	492	1.08
223-12563-9	TB.FITT.ST T10-S CF	S	10	34	22	Steel, galvanized	800	11 600	193	0.43
223-13057-2	TB.FITT.ST T16-S CF	S	16	43	30	Steel, galvanized	630	9 140	418	0.92
223-12366-2	TB.FITT.ST T20-S CF	S	20	48	36	Steel, galvanized	420	6 090	867	1.91
223-12366-6	TB.FITT.ST T30-S CF	S	30	62	50	Steel, galvanized	420	6 090	2 274	5.01
Stainless steel										
223-13616-3	TB.FITT.VA T10-L	L	10	30	19	Stainless steel 1.4571	315	4 570	111	0.24
223-12455-1	TB.FITT.VA T10-S	S	10	34	22	Stainless steel 1.4571	630	9 140	193	0.43
223-12455-5	TB.FITT.VA T16-S	S	16	43	30	Stainless steel 1.4571	400	5 800	418	0.92
223-12455-2	TB.FITT.VA T20-S	S	20	48	36	Stainless steel 1.4571	400	5 800	867	1.91

### Reducing T-connectors TR

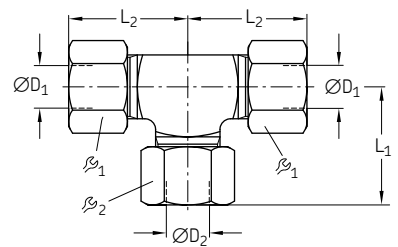

Order number	Designation	Series	Tube ØD <sub>1</sub>	Tube ØD <sub>2</sub>	L <sub>1</sub>	L <sub>2</sub>	β <sub>1</sub>	β <sub>2</sub>	Material	Operating pressure max.		Weight	
										bar	psi	g	lb
			mm	mm	mm	mm	mm	mm					
Steel, galvanized													
223-12573-6	TB.FITT.ST TR10/ 6/10-L CF	L	10	6	30	30	19	14	Steel, galvanized	500	7 250	94	0.21
223-12541-5	TB.FITT.ST TR15/10/15-L CF	L	15	10	36	36	27	19	Steel, galvanized	400	5 800	213	0.47
223-13025-6	TB.FITT.ST TR12/10/12-S CF	S	12	10	38	38	24	22	Steel, galvanized	630	9 140	217	0.48
223-12367-2	TB.FITT.ST TR20/10/20-S CF	S	20	10	46	48	36	22	Steel, galvanized	420	6 090	503	1.11
223-12367-4	TB.FITT.ST TR20/12/20-S CF	S	20	12	46	48	36	24	Steel, galvanized	420	6 090	522	1.15
Stainless steel													
223-13672-8	TB.FITT.VA TR18/10/18-L	L	18	10	39	40	32	19	Stainless steel 1.4571	315	4 570	305	0.67
223-13672-3	TB.FITT.VA TR20/10/20-S	S	20	10	46	48	36	22	Stainless steel 1.4571	400	5 800	529	1.17

## Double-edged cutting sleeve unions

## Elbow connectors W

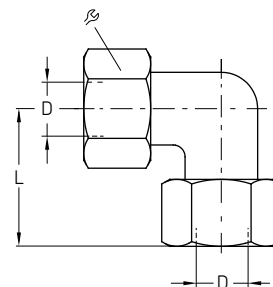

Order number	Designation	Series	Tube	ØD	L	⊘	Material	Operating pressure max.		Weight	
								bar	psi	g	lb
				mm	mm	mm					
Steel, galvanized											
223-12483-2	TB.FITT.ST W6-L CF	L	6	27	14		Steel, galvanized	500	7 250	41	0.09
223-12483-5	TB.FITT.ST W8-L CF	L	8	29	17		Steel, galvanized	500	7 250	60	0.13
223-12483-8	TB.FITT.ST W10-L CF	L	10	30	19		Steel, galvanized	500	7 250	75	0.17
223-12562-2	TB.FITT.ST W15-L CF	L	15	36	27		Steel, galvanized	400	5 800	128	0.28
443-218-001	TB.FITT.ST W18-L CF	L	18	40	32		Steel, galvanized	400	5 800	208	0.46
443-290-001	TB.FITT.ST W22-L CF	L	22	44	36		Steel, galvanized	250	3 625	267	0.59
223-12562-7	TB.FITT.ST W10-S CF	S	10	34	22		Steel, galvanized	800	11 600	133	0.29
223-12562-8	TB.FITT.ST W16-S CF	S	16	43	30		Steel, galvanized	630	9 140	232	0.51
223-12365-2	TB.FITT.ST W20-S CF	S	20	48	36		Steel, galvanized	420	6 090	333	0.73
Stainless steel											
223-14424-5	TB.FITT.VA W 8-L	L	8	29	17		Stainless steel 1.4571	315	4 570	60	0.13
223-13675-2	TB.FITT.VA W 20-S	S	20	48	36		Stainless steel 1.4571	400	5 800	333	0.73

## Elbow screw-in connectors WE with metrical thread

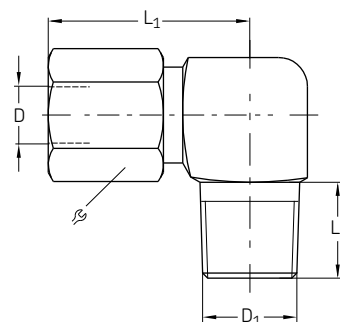

Order number	Designation	Series	Tube	ØD	ØD <sub>1</sub>	L <sub>1</sub>	L <sub>2</sub>	⊘	Material	Operating pressure max.		Weight	
										bar	psi	g	lb
				mm	mm	mm	mm	mm					
Steel, galvanized													
223-13023-2	TB.FITT.ST WE 6-LL M6x1,0K CF	LL	6	M6x1 tap.	19	8	12		Steel, galvanized	100	1 450	24	0.05
223-13023-3	TB.FITT.ST WE 6-LL M8x1K CF	LL	6	M8x1 tap.	21	8	12		Steel, galvanized	100	1 450	24	0.05
223-13021-3	TB.FITT.ST WE 6-LL M10x1K CF	LL	6	M10x1 tap.	15	8	12		Steel, galvanized	100	1 450	24	0.05
223-12362-4	TB.FITT.ST WE 8-LL M10x1K CF	LL	8	M10x1 tap.	17	8	14		Steel, galvanized	100	1 450	33	0.07
223-12485-8	TB.FITT.ST WE 6-L M10x1K CF	L	6	M10x1 tap.	19	8	14		Steel, galvanized	315	4 570	41	0.09
223-12362-8	TB.FITT.ST WE 8-L M12x1,5K CF	L	8	M12x1,5 tap.	21	12	17		Steel, galvanized	315	4 570	63	0.14
410-405	TB.FITT.ST WE10-L M14x1,5K CF	L	10	M14x1,5 tap.	30	12	19		Steel, galvanized	315	4 570	125	0.28
412-405	TB.FITT.ST WE12-L M16x1,5K CF	L	12	M16x1,5 tap.	24	12	22		Steel, galvanized	315	4 570	117	0.26
415-405	TB.FITT.ST WE15-L M18x1,5K CF	L	15	M18x1,5 tap.	28	12	27		Steel, galvanized	315	4 570	125	0.28
223-12485-2	TB.FITT.ST WE10-S M16x1,5K CF	S	10	M16x1,5 tap.	25	12	22		Steel, galvanized	400	5 800	123	0.27
Stainless steel													
404-405-S3	TB.FITT.VA WE 4-LL M 8x1,0K	LL	4	M8x1 tap.	15	8	10		Stainless steel 1.4571	100	1 450	18	0.04
223-13677-2	TB.FITT.VA WE 6-LL M 8x1,0K	LL	6	M8x1 tap.	21	8	12		Stainless steel 1.4571	100	1 450	24	0.05

## Double-edged cutting sleeve unions

# Elbow screw-in connectors WE with Whitworth pipe thread

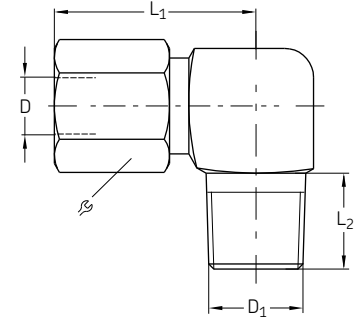

Order number	Designation	Series	Tube ØD	ØD <sub>1</sub>		L <sub>1</sub>	L <sub>2</sub>	S	Material	Operating pressure max.		Weight	
				mm	in					bar	psi	g	lb
Steel, galvanized													
223-13021-4	TB.FITT.ST WE 4-LL R 1/8K CF	LL	4	R 1/8	15	8	10		Steel, galvanized	100	1 450	21	0.05
223-13021-6	TB.FITT.ST WE 8-LL R 1/8K CF	LL	8	R 1/8	17	8	14		Steel, galvanized	100	1 450	32	0.07
96-6112-0058	TB.FITT.ST WE12-LL R 1/4K CF	LL	12	R 1/4	19	12	19		Steel, galvanized	100	1 450	61	0.13
223-13048-1	TB.FITT.ST WE 6-L R 1/8K CF	L	6	R 1/8	19	8	14		Steel, galvanized	315	4 570	42	0.09
223-12380-6	TB.FITT.ST WE 6-L R 1/4K CF	L	6	R 1/4	21	12	14		Steel, galvanized	315	4 570	59	0.13
408-425W	TB.FITT.ST WE 8-L R 1/8K CF	L	8	R 1/8	21	8	17		Steel, galvanized	315	4 570	66	0.15
223-14240-5	TB.FITT.ST WE 8-L R 1/4K CF	L	8	R 1/4	21	12	17		Steel, galvanized	315	4 570	63	0.14
223-13048-5	TB.FITT.ST WE10-L R 1/4K CF	L	10	R 1/4	22	12	19		Steel, galvanized	315	4 570	82	0.18
412-405W	TB.FITT.ST WE12-L R 3/8K CF	L	12	R 3/8	24	12	22		Steel, galvanized	315	4 570	116	0.26
223-13021-7	TB.FITT.ST WE15-L R 1/2K CF	L	15	R 1/2	28	14	27		Steel, galvanized	315	4 570	141	0.31
418-405W	TB.FITT.ST WE18-L R 1/2K CF	L	18	R 1/2	31	14	32		Steel, galvanized	315	4 570	230	0.51
223-13048-6	TB.FITT.ST WE10-S R 3/8K CF	S	10	R 3/8	25	12	22		Steel, galvanized	400	5 800	138	0.30
96-1412-0058	TB.FITT.ST WE12-S R 3/8K CF	S	12	R 3/8	29	12	24		Steel, galvanized	400	5 800	164	0.36
223-13048-8	TB.FITT.ST WE16-S R 1/2K CF	S	16	R 1/2	33	14	30		Steel, galvanized	400	5 800	232	0.51
Stainless steel													
223-13620-8	TB.FITT.VA WE 6-L R 1/8K	L	6	R 1/8	19	8	14		Stainless steel 1.4571	315	4 570	42	0.09
223-13677-5	TB.FITT.VA WE 8-L R 1/4K	L	8	R 1/4	21	12	17		Stainless steel 1.4571	315	4 570	63	0.14
223-12453-1	TB.FITT.VA WE 10-L R 1/4K	L	10	R 1/4	22	12	19		Stainless steel 1.4571	315	4 570	82	0.18

## Double-edged cutting sleeve unions

## K-connectors K

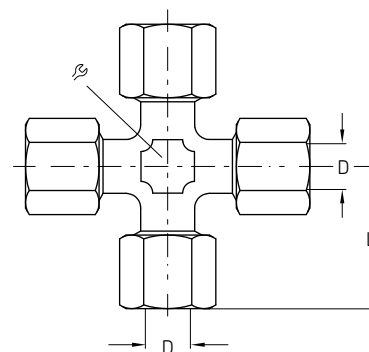

Order number	Designation	Series	Tube ØD		L	⊳	Material	Operating pressure max.		Weight	
			mm	mm				mm	bar	psi	g
96-2106-0058	TB.FITT.ST K 6-LL CF	LL	6	21	12		Steel, galvanized	100	1 450	27	0.06
446-308-001	TB.FITT.ST K 8-LL CF	LL	8	23	14		Steel, galvanized	100	1 450	52	0.11
446-310-001	TB.FITT.ST K10-LL CF	LL	10	30	19		Steel, galvanized	100	1 450	110	0.24
446-312-001	TB.FITT.ST K12-LL CF	LL	12	32	22		Steel, galvanized	100	1 450	129	0.28
446-315-001	TB.FITT.ST K15-LL CF	LL	15	36	27		Steel, galvanized	100	1 450	306	0.67
96-2118-0058	TB.FITT.ST K18-L CF	L	18	40	32		Steel, galvanized	160	2 320	420	0.93
96-2122-0058	TB.FITT.ST K22-LL CF	L	22	44	36		Steel, galvanized	160	2 320	550	1.21
223-12423-7	TB.FITT.ST K10-L CF	L	10	30	19		Steel, galvanized	315	4 570	136	0.30
223-12432-2	TB.FITT.ST K10-S CF	S	10	34	22		Steel, galvanized	630	9 140	233	0.51
223-12432-8	TB.FITT.ST K20-S CF	S	20	48	36		Steel, galvanized	315	4 570	791	1.74

## Double-edged cutting sleeve unions

### Female connector straight GAI with metric thread

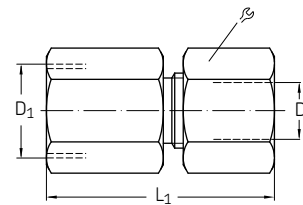

Order number	Designation	Series	Tube ØD	ØD <sub>1</sub>	L <sub>1</sub>	L <sub>2</sub>	R	Material	Operating pressure max.		Weight	
									bar	psi	g	lb
223-10307-2	TB.FITT.ST GAI 6-L M10x1,0 CF	L	6	M10x1	26,5	19,5	14	Steel, galvanized	315	4 570	30	0.07
96-0508-0060	TB.FITT.ST GAI 8-L M12x1,5 CF	L	8	M12x1,5	31	24	17	Steel, galvanized	315	4 570	49	0.11
223-13033-2	TB.FITT.ST GAI10-L M14x1,5 CF	L	10	M14x1,5	32	25	19	Steel, galvanized	315	4 570	60	0.13
96-0512-0060	TB.FITT.ST GAI12-L M16x1,5 CF	L	12	M16x1,5	33	26	22	Steel, galvanized	315	4 570	80	0.18
223-13693-9	TB.FITT.ST GAI18-L M22x1,5 CF	L	18	M22x1,5	37	29,5	32	Steel, galvanized	315	4 570	179	0.39
96-0606-0060	TB.FITT.ST GAI 6-S M12x1,5 CF	S	6	M12x1	33	26	17	Steel, galvanized	400	5 800	54	0.12
96-0608-0060	TB.FITT.ST GAI 8-S M14x1,5 CF	S	8	M14x1,5	33	26	19	Steel, galvanized	400	5 800	73	0.16

### Female connector straight GAI with Whitworth pipe thread

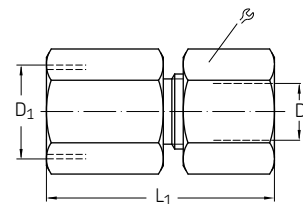

Order number	Designation	Series	Tube ØD	ØD <sub>1</sub>	L <sub>1</sub>	L <sub>2</sub>	R	Material	Operating pressure max.		Weight	
									bar	psi	g	lb
Steel, galvanized												
223-13693-4	TB.FITT.ST GAI 6-L G1/8 CF	L	6	G 1/8	26	19	14	Steel, galvanized	315	4 570	30	0.07
223-13693-6	TB.FITT.ST GAI 8-L G1/4 CF	L	8	G 1/4	31	24	19	Steel, galvanized	315	4 570	56	0.12
223-13693-2	TB.FITT.ST GAI10-L G1/4 CF	L	10	G 1/4	32	25	19	Steel, galvanized	315	4 570	61	0.13
96-0712-0060	TB.FITT.ST GAI12-L G3/8 CF	L	12	G 3/8	33	26	24	Steel, galvanized	315	4 570	92	0.20
96-0715-0060	TB.FITT.ST GAI15-L G1/2 CF	L	15	G 1/2	38	31	27	Steel, galvanized	315	4 570	134	0.30
96-0718-0060	TB.FITT.ST GAI18-L G1/2 CF	L	18	G 1/2	38	30,5	27	Steel, galvanized	315	4 570	157	0.35
223-12273-2	TB.FITT.ST GAI22-L G3/4 CF	L	22	G 3/4	43	35,5	36	Steel, galvanized	160	2 320	262	0.58
223-13693-1	TB.FITT.ST GAI10-S G3/8 CF	S	10	G 3/8	33	26	24	Steel, galvanized	315	4 570	84	0.19
Stainless steel												
223-14116-9	TB.FITT.VA GAI20-S G3/4	S	20	G 3/4	45	34,5	36	Stainless steel 1.4571	315	4 570	309	0.68

## Double-edged cutting sleeve unions

## Check valves GERV

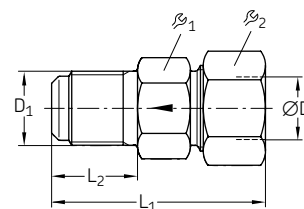

Order number	Designation	Series	Tube ØD	ØD <sub>1</sub>	L <sub>1</sub>	L <sub>2</sub>	β <sub>1</sub>	β <sub>2</sub>	Material	Operating pressure max.		Weight	
										bar	psi	g	lb
				mm	mm	mm	mm	mm					
Steel, galvanized													
223-12290-7	CHECK VALVE ST GERV 6-LL G 1/8A L CF LL	6	G 1/8	30	11	12	11	11	Steel, galvanized	100	1 450	16	0.04
223-13052-8	CHECK VALVE ST GERV 6-LL M10×1 L CF LL	6	M0×1	30	11	12	11	11	Steel, galvanized	100	1 450	15	0.03
223-13051-1	CHECK VALVE ST GERV 8-L G 1/4A L CF L	8	G 1/4	42	14	17	17	17	Steel, galvanized	400	5 800	45	0.10
223-13051-2	CHECK VALVE ST GERV10 -L G 1/4A L CF L	10	G 1/4	41	14	19	19	19	Steel, galvanized	400	5 800	60	0.13
223-12372-9	CHECK VALVE ST GERV 6-S G 1/4A L CF S	6	G 1/4	44	14	17	17	17	Steel, galvanized	420	6 090	60	0.13
Stainless steel													
223-12535-9	CHECK VALVE VA GERV 6-LL G 1/8A L LL	6	G 1/8	30	11	12	11	11	Stainless steel 1.4571	100	1 450	16	0.04
223-11185-1	CHECK VALVE VA GERV 6-S G 1/4A L S	6	G 1/4	44	14	17	17	17	Stainless steel 1.4571	400	5 800	60	0.13

## Check valves RHV

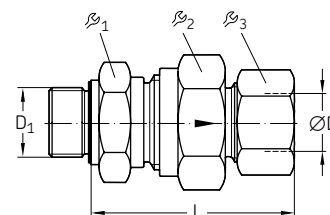

Order number	Designation	Series	Tube ØD	ØD <sub>1</sub>	L	β <sub>1</sub>	β <sub>2</sub>	β <sub>3</sub>	Material	Operating pressure max.		Weight	
										bar	psi	g	lb
				mm	in	mm	mm	mm	mm				
Steel, galvanized													
223-14464-9	CHECK VALVE ST RHV 6-L G 1/8AV CF L	6	G 1/8	42,5	17	17	14	14	Steel, galvanized	400	5 800	59	0.13
223-13079-1	CHECK VALVE ST RHV 8-L G 1/4AV CF L	8	G 1/4	44,5	19	19	17	17	Steel, galvanized	400	5 800	89	0.20
223-12291-4	CHECK VALVE ST RHV10-L G 1/4AV CF L	10	G 1/4	53	22	24	19	19	Steel, galvanized	400	5 800	126	0.28
223-12429-1	CHECK VALVE ST RHV 6-S G 1/4AV CF S	6	G 1/4	46	19	19	17	17	Steel, galvanized	420	6 090	82	0.18
223-12291-2	CHECK VALVE ST RHV 8-S G 1/4AV CF S	8	G 1/4	46	19	19	19	19	Steel, galvanized	420	6 090	102	0.22
223-12291-6	CHECK VALVE ST RHV10-S G 3/8AV CF S	10	G 3/8	54	22	24	22	22	Steel, galvanized	420	6 090	166	0.37

## Double-edged cutting sleeve unions

### Check valves RHZ

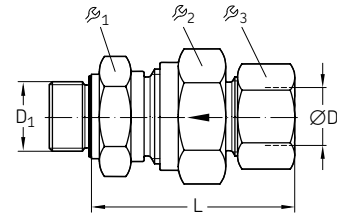

Order number	Designation	Series	Tube ØD	L	ϕ <sub>1</sub>	ϕ <sub>2</sub>	ϕ <sub>3</sub>	Material	Operating pressure max.		Weight		
									bar	psi	g	lb	
Steel, galvanized													
223-12292-2	CHECK VALVE ST RHZ 6-L G 1/8A-ED L CF	L	6	G 1/8	41	17	17	14	Steel, galvanized	400	5 800	51	0.11
223-12292-5	CHECK VALVE ST RHZ10-L G 1/4A L CF	L	10	G 1/4	53	22	24	19	Steel, galvanized	400	5 800	148	0.33
223-13706-3	CHECK VALVE ST RHZ 6-L M10×1.0 L CF	L	6	M10×1	41	17	17	14	Steel, galvanized	400	5 800	51	0.11
223-12292-9	CHECK VALVE ST RHZ 6-S G 1/4A L CF	S	6	G 1/4	46	19	19	17	Steel, galvanized	420	6 090	80	0.18
Stainless steel													
223-13692-3	CHECK VALVE VA RHZ 6-L G 1/8A L	L	6	G 1/8	41	17	17	14	Stainless steel 1.4571	250	3 625	51	0.11

### Check valves RHD

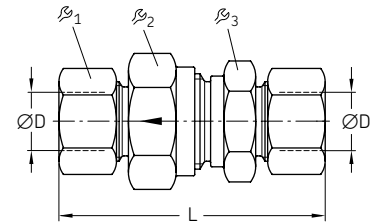

Order number	Designation	Series	Tube ØD	L	ϕ <sub>1</sub>	ϕ <sub>2</sub>	ϕ <sub>3</sub>	Material	Operating pressure max.		Weight	
									bar	psi	g	lb
Steel, galvanized												
223-13643-8	CHECK VALVE ST RHD 6-L CF	L	6	58	17	17	14	Steel, galvanized	400	5 800	70	0.15
223-13643-3	CHECK VALVE ST RHD 8-L CF	L	8	59	19	19	17	Steel, galvanized	400	5 800	95	0.21
223-13643-2	CHECK VALVE ST RHD10-L CF	L	10	69,5	22	24	19	Steel, galvanized	400	5 800	146	0.32
223-14464-8	CHECK VALVE ST RHD18-L CF	L	18	83,5	36	36	32	Steel, galvanized	400	5 800	428	0.94
223-13643-1	CHECK VALVE ST RHD10-S CF	S	10	72,5	22	24	22	Steel, galvanized	420	6 090	189	0.42
223-13643-4	CHECK VALVE ST RHD16-S CF	S	16	86,5	32	36	30	Steel, galvanized	420	6 090	430	0.95
223-13643-6	CHECK VALVE ST RHD20-S CF	S	20	97,5	41	46	36	Steel, galvanized	420	6 090	732	1.61
Stainless steel												
223-13770-6	CHECK VALVE VA RHD 6-L	L	6	58	17	17	14	Stainless steel 1.4571	250	3 625	70	0.15
223-13770-5	CHECK VALVE VA RHD20-S	S	20	97,5	41	46	36	Stainless steel 1.4571	250	3 625	732	1.61

## Double-edged cutting sleeve unions

## Straight bulkhead connectors SV

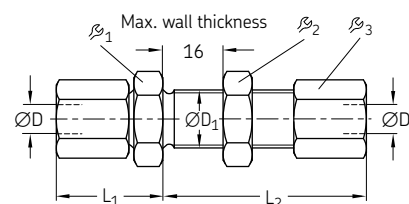

Order number	Designation	Series	Tube ØD	ØD <sub>1</sub>	L <sub>1</sub>	L <sub>2</sub>	Ø <sub>1</sub>	Ø <sub>2</sub>	Ø <sub>3</sub>	Material	Operating pressure max.		Weight	
											bar	psi	g	lb
				mm	mm	mm	mm	mm	mm					
Steel, galvanized														
223-12368-4	TB.FITT.ST SV 6-L CF	L	6	12,5	22	42	17	17	14	Steel, galvanized	500	7 250	63	0.14
223-12368-6	TB.FITT.ST SV 8-L CF	L	8	14,5	23	42	19	19	17	Steel, galvanized	500	7 250	84	0.19
223-12368-8	TB.FITT.ST SV 10-L CF	L	10	16,5	25	43	22	22	19	Steel, galvanized	500	7 250	109	0.24
223-13698-4	TB.FITT.ST SV 12-L CF	L	12	18,5	25	44	24	24	22	Steel, galvanized	400	5 800	134	0.30
223-12564-2	TB.FITT.ST SV 15-L CF	L	15	22,5	27	46	27	30	27	Steel, galvanized	400	5 800	222	0.49
223-12564-8	TB.FITT.ST SV 18-L CF	L	18	26,5	30	49	32	36	32	Steel, galvanized	400	5 800	334	0.74
422-416	TB.FITT.ST SV22-L CF	L	22	30,5	33	51	36	41	36	Steel, galvanized	250	3 625	432	0.95
223-12564-6	TB.FITT.ST SV 10-S CF	S	10	18,5	31	46	24	24	22	Steel, galvanized	800	11 600	180	0.40
223-12368-2	TB.FITT.ST SV 20-S CF	S	20	30,5	39	55	41	41	36	Steel, galvanized	420	6 090	688	1.52
Stainless steel														
223-13671-9	TB.FITT.VA SV 8-S	S	8	16,5	28	44	22	22	19	Stainless steel 1.4571	630	9 140	133	0.29
223-12564-3	TB.FITT.VA SV 10-S	S	10	18,5	31	46	24	24	22	Stainless steel 1.4571	630	9 140	180	0.40
223-13671-2	TB.FITT.VA SV 20-S	S	20	30,5	39	55	41	41	36	Stainless steel 1.4571	400	5 800	688	1.52

## Elbow bulkhead connectors WSV

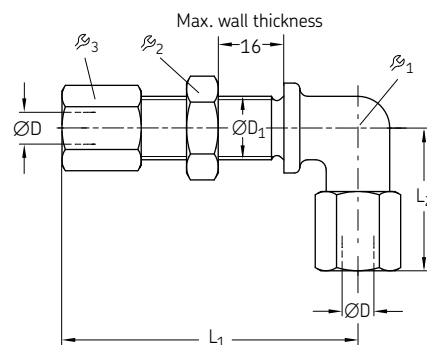

Order number	Designation	Series	Tube ØD	ØD <sub>1</sub>	L <sub>1</sub>	L <sub>2</sub>	Ø <sub>1</sub>	Ø <sub>2</sub>	Ø <sub>3</sub>	Material	Operating pressure max.		Weight	
											bar	psi	g	lb
				mm	mm	mm	mm	mm	mm					
Steel, galvanized														
223-13050-4	TB.FITT.ST WSV 6-L CF	L	6	12,5	48	27	12	17	14	Steel, galvanized	315	4 570	75	0.17
223-12409-6	TB.FITT.ST WSV 8-L CF	L	8	14,5	51	29	12	19	17	Steel, galvanized	315	4 570	95	0.21
223-12409-9	TB.FITT.ST WSV10-L CF	L	10	16,5	53	30	14	22	19	Steel, galvanized	315	4 570	120	0.26
412-409	TB.FITT.ST WSV12-L CF	L	12	18,5	56	32	17	24	22	Steel, galvanized	315	4 570	141	0.31
223-12409-8	TB.FITT.ST WSV15-L CF	L	15	22,5	61	36	19	30	27	Steel, galvanized	315	4 570	184	0.41
418-409	TB.FITT.ST WSV18-L CF	L	18	26,5	64	40	24	36	32	Steel, galvanized	315	4 570	374	0.82
223-13050-2	TB.FITT.ST WSV10-S CF	S	10	18,5	57	34	17	24	22	Steel, galvanized	630	9 140	196	0.43
223-12409-2	TB.FITT.ST WSV20-S CF	S	20	30,5	74	48	27	41	36	Steel, galvanized	400	5 800	616	1.36
Stainless steel														
223-10364-6	TB.FITT.VA WSV 8-S	S	8	16,5	54	32	14	22	19	Stainless steel 1.4571	630	9 140	155	0.34
223-10364-3	TB.FITT.VA WSV10-S	S	10	18,5	57	34	17	24	22	Stainless steel 1.4571	630	9 140	196	0.43



## Double-edged cutting sleeve unions

### Banjo fittings SWVE with metrical thread

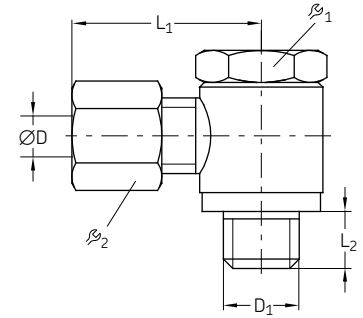

Order number	Designation	Series	Tube ØD	D <sub>1</sub>	L <sub>1</sub>	L <sub>2</sub>	β <sub>1</sub>	β <sub>2</sub>	Material	Operating pressure max.		Weight	
										mm	mm	mm	mm
Steel, galvanized													
223-12480-2	TB.FITT.ST SWVE 4-LL M 8x1 CF	LL	4	M8x1	20	6	12	10	Steel, galvanized	63	915	22	0.05
223-12480-7	TB.FITT.ST SWVE 6-LL M10x1 CF	LL	6	M10x1	22	6	14	12	Steel, galvanized	63	915	36	0.08
223-12369-7	TB.FITT.ST SWVE 6-L M10x1 CF	L	6	M10x1	25	6	14	14	Steel, galvanized	160	2 320	43	0.09
96-7808-0058	TB.FITT.ST SWVE 8-L M12x1,5 CF	L	8	M12x1,5	27	9	17	17	Steel, galvanized	160	2 320	68	0.15
445-535-101	TB.FITT.ST SWVE10-L M14x1,5 CF	L	10	M14x1,5	29	9	19	19	Steel, galvanized	160	2 320	89	0.20
96-7812-0058	TB.FITT.ST SWVE12-L M16x1,5 CF	L	12	M16x1,5	30	9	21	22	Steel, galvanized	100	1 450	128	0.28
96-7815-0058	TB.FITT.ST SWVE15-L M18x1,5 CF	L	15	M18x1,5	33	9	24	27	Steel, galvanized	100	1 450	185	0.41
96-7818-0058	TB.FITT.ST SWVE18-L M22x1,5 CF	L	18	M22x1,5	37	11	27	32	Steel, galvanized	100	1 450	309	0.68
96-7822-0058	TB.FITT.ST SWVE22-L M26x1,5 Z3	L	22	M26x1,5	42	13	32	36	Steel, galvanized	100	1 450	440	0.97
223-13669-4	TB.FITT.ST SWVE10-S M16x1,5 CF	S	10	M16x1,5	32	9	22	22	Steel, galvanized	100	1 450	140	0.31
96-8012-0058	TB.FITT.ST SWVE12-S M18x1,5 CF	S	12	M18x1,5	33	9	24	24	Steel, galvanized	100	1 450	172	0.38
96-8014-0058	TB.FITT.ST SWVE14-S M20x1,5 Z3	S	14	M20x1,5	38	11	27	27	Steel, galvanized	100	1 450	236	0.52
96-8016-0058	TB.FITT.ST SWVE16-S M22x1,5 Z3	S	16	M22x1,5	40	11	27	30	Steel, galvanized	100	1 450	324	0.71
Stainless steel													
223-12456-6	TB.FITT.VA SWVE 6-LL M10x1	LL	6	M10x1	22	6	14	12	Stainless steel 1.4571	63	915	36	0.08
223-14089-9	TB.FITT.VA SWVE 6-L M10x1	L	6	M10x1	25	6	14	14	Stainless steel 1.4571	160	2 320	43	0.09

### Banjo fittings SWVE with Whitworth pipe thread

Order number	Designation	Series	Tube ØD	D <sub>1</sub>	L <sub>1</sub>	L <sub>2</sub>	β <sub>1</sub>	β <sub>2</sub>	Material	Operating pressure max.		Weight	
										mm	in	mm	mm
Steel, galvanized													
223-13629-1	TB.FITT.ST SWVE 4-LL G 1/8A CF	LL	4	G 1/8A	21	6	14	10	Steel, galvanized	63	915	32	0.07
223-12479-9	TB.FITT.ST SWVE 6-LL G 1/8A CF	LL	6	G 1/8A	22	6	14	12	Steel, galvanized	63	915	35	0.08
223-12479-8	TB.FITT.ST SWVE 8-LL G 1/8A CF	LL	8	G 1/8A	23	6	14	14	Steel, galvanized	63	915	38	0.08
223-12479-5	TB.FITT.ST SWVE 6-L G 1/8A CF	L	6	G 1/8A	25	6	14	14	Steel, galvanized	160	2 320	43	0.09
223-12284-7	TB.FITT.ST SWVE 8-L G 1/4A CF	L	8	G 1/4A	28	9	19	17	Steel, galvanized	160	2 320	82	0.18
223-12369-9	TB.FITT.ST SWVE10-L G 1/4A CF	L	10	G 1/4A	29	9	19	22	Steel, galvanized	160	2 320	87	0.19
223-13669-3	TB.FITT.ST SWVE12-L G 3/8A CF	L	12	G 3/8A	30	9	19	22	Steel, galvanized	100	1 450	130	0.29
223-12285-8	TB.FITT.ST SWVE 6-S G 1/4A CF	S	6	G 1/4A	30	9	19	17	Steel, galvanized	160	2 320	88	0.19
223-12285-9	TB.FITT.ST SWVE 8-S G 1/4A CF	S	8	G 1/4A	30	9	19	19	Steel, galvanized	160	2 320	96	0.21
223-12285-5	TB.FITT.ST SWVE10-S G 3/8A CF	S	10	G 3/8A	32	9	22	22	Steel, galvanized	100	1 450	142	0.31
223-12285-6	TB.FITT.ST SWVE12-S G 3/8A CF	S	12	G 3/8A	33	9	24	24	Steel, galvanized	100	1 450	185	0.41
96-7914-0058	TB.FITT.ST SWVE14-S G 1/2A Z3	S	14	G 1/2A	38	11	27	27	Steel, galvanized	100	1 450	234	0.52
96-7916-0058	TB.FITT.ST SWVE16-S G 1/2A CF	S	16	G 1/2A	40	11	27	30	Steel, galvanized	100	1 450	321	0.71
223-12285-7	TB.FITT.ST SWVE20-S G 3/4A CF	S	20	G 3/4A	46	13	32	36	Steel, galvanized	100	1 450	472	1.04
Stainless steel													
223-12456-7	TB.FITT.VA SWVE 6-LL G 1/8A	LL	6	G 1/8A	22	6	14	12	Stainless steel 1.4571	63	915	35	0.08
223-12456-9	TB.FITT.VA SWVE 8-L G 1/4A	L	8	G 1/4A	28	9	19	17	Stainless steel 1.4571	160	2 320	82	0.18
223-12456-1	TB.FITT.VA SWVE 10-L G 1/4A	L	10	G 1/4A	29	9	19	22	Stainless steel 1.4571	160	2 320	87	0.19
223-10389-4	TB.FITT.VA SWVE 6-S G 1/4A	S	6	G 1/4A	22	9	19	17	Stainless steel 1.4571	160	2 320	45	0.10

## Double-edged cutting sleeve unions

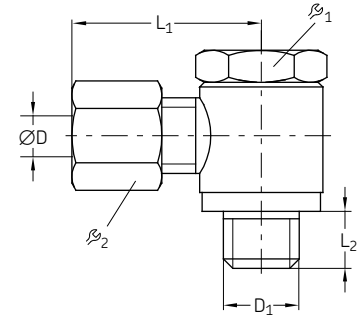
Banjo fittings WHK (high-pressure) <sup>1)</sup>  
with metrical thread

Order number	Designation	Series	Tube ØD	D <sub>1</sub>	L <sub>1</sub>	L <sub>2</sub>	r <sub>1</sub>	r <sub>2</sub>	Material	Operating pressure max.		Weight	
										bar	psi	g	lb
				mm	mm	mm	mm	mm					
96-5506-0058	TB.FITT. ST WHK 6-S M12x1,5 CF	S	6	M12x1,5	27	12	17	17	Steel, galvanized	315	4 569	75	0.16
96-8006-0058	TB.FITT. ST WHK 6-S M12x1,5 CF	S	6	M12x1,5	30	12	17	17	Steel, galvanized	315	4 569	75	0.16
96-7108-0058	TB.FITT. ST WHK 8-LL M10x1,0 CF	LL	8	M10x1,0	23	8	13	14	Steel, galvanized	100	1 450	35	0.07
96-8008-0058	TB.FITT. ST WHK 8-S M14x1,5 CF	S	8	M14x1,5	30	12	17	19	Steel, galvanized	315	4 569	84	0.18
96-5510-0058	TB.FITT. ST WHK10-S M16x1,5 CF	S	10	M16x1,5	32	12	22	22	Steel, galvanized	315	4 569	138	0.30
223-13679-9	TB.FITT. ST WHK10-S M16x1,5-CS CF	S	10	M16x1,5	32	12	22	22	Steel, galvanized	420	6 092	138	0.30
223-13679-6	TB.FITT. ST WHK12-L M14x1,5-CS CF	L	12	M14x1,5	31	12	17	19	Steel, galvanized	250	3 626	102	0.22
96-5315-0058	TB.FITT. ST WHK15-L M18x1,5 CF	L	15	M18x1,5	34	12	24	27	Steel, galvanized	250	3 626	182	0.40

<sup>1)</sup> WHK means improved and consolidated WH fittings

Banjo fittings WH and WHK (high-pressure) <sup>1)</sup>  
with Whitworth pipe thread

Order number	Designation	Series	Tube ØD	D <sub>1</sub>	L <sub>1</sub>	L <sub>2</sub>	r <sub>1</sub>	r <sub>2</sub>	Material	Operating pressure max.		Weight	
										bar	psi	g	lb
				mm	mm	mm	mm	mm					
Steel, galvanized													
445-516-061	TB.FITT. ST WHK 6-L G 1/4A CF	L	6	G 1/8 A	25	8	13	14	Steel, galvanized	250	3 626	35	0.07
96-5208-0058-EO	TB.FITT. ST WHK 8-L G 1/4A CF	L	8	G 1/4 A	27	12	17	17	Steel, galvanized	250	3 626	70	0.15
223-13679-8	TB.FITT. ST WHK10-L G 1/4A-CS CF	L	10	G 1/4 A	29	12	17	19	Steel, galvanized	420	6 092	73	0.16
96-5410-0058	TB.FITT. ST WHK10-S G 1/8A CF	S	10	G 3/8 A	32	12	22	22	Steel, galvanized	315	4 570	140	0.30
223-14256-4	TB.FITT. ST XWHK10-S G 3/8A CF <sup>2)</sup>	S	10	G 3/8 A	32	12	22	22	Steel, galvanized	315	4 570	140	0.30
223-13679-3	TB.FITT. ST WH10-S G3/8A-KD CF	S	10	G 3/8 A	35	12	24	22	Steel, galvanized	400	5 800	212	0.47
223-14256-3	TB.FITT. ST XWHK12-L G 3/8A CF <sup>2)</sup>	L	12	G 3/8 A	31	12	22	22	Steel, galvanized	250	3 626	135	0.29
96-5212-0058	TB.FITT. ST WHK12-L G 3/8A CF	L	12	G 3/8 A	31	12	22	22	Steel, galvanized	250	3 626	135	0.29
223-12539-6	TB.FITT. ST WHK12-L G 3/4A CF	L	12	G 3/8 A	31	12	22	22	Steel, galvanized	420	6 092	135	0.29
96-5215-0058	TB.FITT. ST WHK15-L G 1/2A CF	L	15	G 1/2 A	36	14	27	27	Steel, galvanized	250	3 626	254	0.55
96-5416-0058	TB.FITT. ST WHK16-S G 1/2A CF	S	16	G 1/2 A	40	14	27	30	Steel, galvanized	315	4 570	266	0.58
445-513-181	TB.FITT. ST WHK18-L G 1/2A CF	L	18	G 1/2 A	37	14	27	32	Steel, galvanized	250	3 626	260	0.57
445-517-222	TB.FITT. ST WHK22-L G 3/4A CF	L	22	G 3/4 A	42	16	32	36	Steel, galvanized	160	2 320	413	0.91
Stainless steel													
223-14238-4	TB.FITT. VA WH10-L G1/4A	L	10	G 1/4 A	30	12	19	19	Stainless steel 1.4571	315	4 570	123	0.27
223-10057-7	TB.FITT. VA XWHK16-S G 1/2A-CS <sup>2)</sup>	S	16	G 1/2 A	40	14	27	30	Stainless steel 1.4571	350	5 076	266	0.58
223-10057-8	TB.FITT. VA XWHK10-S G 3/8A-CS <sup>2)</sup>	S	16	G 3/8 A	42	12	22	22	Stainless steel 1.4571	420	6 092	140	0.30

<sup>1)</sup> WHK means improved and consolidated WH fittings

<sup>2)</sup> Prefix X means fitting without cutting sleeve and without union nut

## Double-edged cutting sleeve unions

# Reducing connectors RED with cylindrical thread

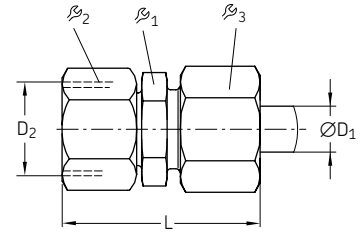

Order number	Designation	Series	Tube ØD	Tube ØD <sub>1</sub>	D <sub>2</sub>	L	ϕ <sub>1</sub>	ϕ <sub>2</sub>	ϕ <sub>3</sub>	Material	Operating pressure max.		Weight	
											bar	psi	g	lb
			mm	mm	mm	mm	mm	mm	mm				mm	mm
96-1406-0060	TB.FITT.ST RED 6/4-LL CF	LL	6	4	M10×1	29	-	12	10	Steel, galvanized	100	1 450	21	0.05
96-1408-0060	TB.FITT.ST RED 8/4-LL CF	LL	8	4	M12×1	29	-	14	10	Steel, galvanized	100	1 450	28	0.06
96-1410-0060	TB.FITT.ST RED 8/6-LL CF	LL	8	6	M12×1	29	-	14	12	Steel, galvanized	100	1 450	32	0.07
223-10670-3	TB.FITT.ST RED 8/6-L CF	L	8	6	M14×1,5	38,0	12	17	14	Steel, galvanized	500	7 250	36	0.08
223-12582-5	TB.FITT.ST RED10/6-L CF	L	10	6	M16×1,5	40,0	14	19	14	Steel, galvanized	500	7 250	48	0.11
473-808-371	TB.FITT.ST RED10/8-L CF	L	10	8	M16×1,5	40	17	22	17	Steel, galvanized	500	7 250	58	0.13
223-13699-7	TB.FITT.ST RED12/6-L CF	L	12	6	M20×1,5	40	17	22	14	Steel, galvanized	400	5 800	60	0.13
473-808-392	TB.FITT.ST RED12/8-L CF	L	12	8	M18×1,5	40	17	22	17	Steel, galvanized	400	5 800	69	0.15
223-14293-2	TB.FITT.ST RED12/10-L CF	L	12	10	M18×1,5	41,0	17	22	19	Steel, galvanized	400	5 800	63	0.14
223-14152-2	TB.FITT.ST RED15/8-L CF	L	15	8	M22×1,5	43,0	19	27	17	Steel, galvanized	400	5 800	102	0.22
223-14293-4	TB.FITT.ST RED15/10-L CF	L	15	10	M22×1,5	44,0	19	27	19	Steel, galvanized	400	5 800	104	0.23
223-14293-8	TB.FITT.ST RED18/15-L CF	L	18	15	M26×1,5	45,0	24	32	27	Steel, galvanized	400	5 800	162	0.36
223-10688-1	TB.FITT.ST RED 8/6-S CF	S	8	6	M16×1,5	42	14	19	17	Steel, galvanized	800	11 600	61	0.13
223-10187-1	TB.FITT.ST RED10/6-S CF	S	10	6	M18×1,5	42	17	22	17	Steel, galvanized	800	11 600	74	0.16
223-13054-4	TB.FITT.ST RED10/8-S CF	S	10	8	M18×1,5	42	17	22	19	Steel, galvanized	800	11 600	81	0.18
223-12287-8	TB.FITT.ST RED12/8-S CF	S	12	8	M20×1,5	44	17	24	19	Steel, galvanized	630	9 140	91	0.20
223-12288-2	TB.FITT.ST RED12/10-S CF	S	12	10	M20×1,5	46	19	24	22	Steel, galvanized	630	9 140	109	0.24
96-1633-0060	TB.FITT.ST RED14/10-S CF	S	14	10	M22×1,5	47	19	27	22	Steel, galvanized	630	9 140	125	0.28
96-1642-0060	TB.FITT.ST RED16/8-S CF	S	16	8	M24×1,5	47	22	30	19	Steel, galvanized	630	9 140	137	0.30
223-14293-1	TB.FITT.ST RED16/10-S CF	S	16	10	M24×1,5	48	22	30	22	Steel, galvanized	630	9 140	149	0.33
96-1644-0060	TB.FITT.ST RED16/12-S CF	S	16	12	M24×1,5	48	22	30	24	Steel, galvanized	630	9 140	156	0.34
223-12577-8	TB.FITT.ST RED20/6-S CF	S	20	6	M30×2	51	27	36	17	Steel, galvanized	420	6 090	191	0.42
96-1652-0060	TB.FITT.ST RED20/8-S CF	S	20	8	M30×2	51	27	36	19	Steel, galvanized	420	6 090	197	0.43
223-12577-2	TB.FITT.ST RED20/10-S CF	S	20	10	M30×2	52	27	36	22	Steel, galvanized	420	6 090	208	0.46
223-12580-2	TB.FITT.ST RED20/12-S CF	S	20	12	M30×2	52	27	36	24	Steel, galvanized	420	6 090	215	0.47
223-13759-7	TB.FITT.ST RED20/16-S CF	S	20	16	M30×2	55	27	36	30	Steel, galvanized	420	6 090	254	0.56

# Reducing connectors KOR with cylindrical thread

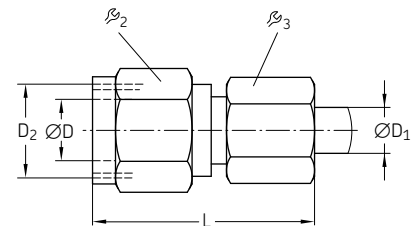

Order number	Designation	Series	Tube ØD	Tube ØD <sub>1</sub>	D <sub>2</sub>	L	ϕ <sub>2</sub>	ϕ <sub>3</sub>	Material	Operating pressure max.		Weight	
										bar	psi	g	lb
			mm	mm	mm	mm	mm	mm				mm	mm
96-1541-0060	TB.FITT.ST KOR18/6-L CF	L	18	6	M26×1,5	43,0	32	14	Steel, galvanized	400	5 800	121	0.27
96-1542-0060	TB.FITT.ST KOR18/8-L CF	L	18	8	M26×1,5	43,0	32	17	Steel, galvanized	400	5 800	128	0.28
96-1543-0060	TB.FITT.ST KOR18/10-L CF	L	18	10	M26×1,5	44,0	32	19	Steel, galvanized	400	5 800	131	0.29
96-1551-0060	TB.FITT.ST KOR22/6-L CF	L	22	6	M30×2	47,0	36	14	Steel, galvanized	250	3 625	170	0.37
96-1556-0060	TB.FITT.ST KOR22/18-L CF	L	22	18	M30×2	50,0	36	32	Steel, galvanized	250	3 625	235	0.52

## Double-edged cutting sleeve unions

## Connectors for pressure gauges MAV

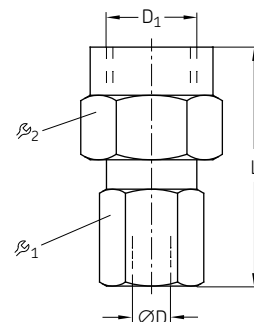

Order number	Designation	Series	Tube ØD	D <sub>1</sub>	L	ϕ <sub>1</sub>	ϕ <sub>2</sub>	Material	Operating pressure max.		Weight	
									bar	psi	g	lb
Steel, galvanized												
223-12481-4	TB.FITT.ST MAV 6-L G 1/4 CF	L	6	G 1/4	37	19	14	Steel, galvanized	315	4 570	49	0.11
223-12481-6	TB.FITT.ST MAV 8-L G 1/4 CF	L	8	G 1/4	37	19	17	Steel, galvanized	315	4 570	55	0.12
223-13028-2	TB.FITT.ST MAV10-L G 1/4 CF	L	10	G 1/4	38	19	19	Steel, galvanized	315	4 570	62	0.14
223-12481-8	TB.FITT.ST MAV12-L G 1/4 CF	L	12	G 1/4	38	19	22	Steel, galvanized	315	4 570	71	0.16
96-8906-0058	TB.FITT.ST MAV 6-S G 1/2 CF	S	6	G 1/2	42,5	27	17	Steel, galvanized	630	9 140	95	0.21
441-108-132	TB.FITT.ST MAV 8-S G 1/2 CF	S	8	G 1/2	46	27	19	Steel, galvanized	630	9 140	105	0.23
223-13028-4	TB.FITT.ST MAV10-S G 1/2 CF	S	10	G 1/2	47	27	22	Steel, galvanized	630	9 140	111	0.24
223-12286-8	TB.FITT.ST MAV12-S G 1/2 CF	S	12	G 1/2	47	27	24	Steel, galvanized	630	9 140	131	0.29
Stainless steel												
223-13685-1	TB.FITT.VA MAV10-S G 1/2	S	10	G 1/2	47	27	22	Stainless steel 1.4571	630	9 140	111	0.24

## Connectors for pressure gauges MAVE

(Swivel with O-ring)

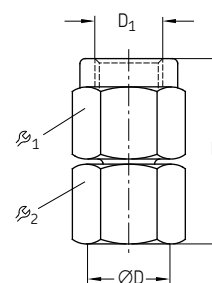

Order number	Designation	Series	Tube ØD	D <sub>1</sub>	L	ϕ <sub>1</sub>	ϕ <sub>2</sub>	Material	Operating pressure max.		Weight	
									bar	psi	g	lb
Steel, galvanized												
223-13655-1	TB.FITT.ST MAVE 6-L G 1/4 CF	L	6	G 1/4	35,5	19	14	Steel, galvanized	315	4 570	46	0.10
223-10889-2	TB.FITT.ST MAVE 8-L G 1/4 CF	L	8	G 1/4	35,5	19	17	Steel, galvanized	315	4 570	52	0.11
223-13655-7	TB.FITT.ST MAVE10-L G 1/4 CF	L	10	G 1/4	36,0	19	19	Steel, galvanized	315	4 570	59	0.13
223-14268-4	TB.FITT.ST MAVE12-L G 1/4 CF	L	12	G 1/4	36,0	19	22	Steel, galvanized	315	4 570	70	0.15
2230-00000116	TB.FITT.ST MAVE 6-S G 1/2 CF	S	6	G 1/2	42,5	27	17	Steel, galvanized	630	9 140	95	0.21
223-13655-2	TB.FITT.ST MAVE10-S G 1/2 CF	S	10	G 1/2	43,5	27	22	Steel, galvanized	630	9 140	109	0.24
223-13655-4	TB.FITT.ST MAVE12-S G 1/2 CF	S	12	G 1/2	45,0	27	24	Steel, galvanized	630	9 140	125	0.28
Stainless steel												
223-14268-7	TB.FITT.VA MAVE 6-L G 1/4	L	6	G 1/4	35,5	19	14	Stainless steel 1.4571	315	4 570	46	0.10

## Double-edged cutting sleeve unions

### L-connectors EL directionally adjustable

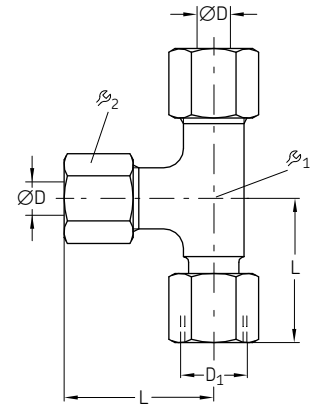

Order number	Designation	Series	Tube ØD	ØD <sub>1</sub>	L	β <sub>1</sub>	β <sub>2</sub>	Material	Operating pressure max.		Weight	
									bar	psi	g	lb
			mm	mm	mm	mm	mm					
Steel, galvanized												
223-14190-6	TB.STUD ST EL 6-L CF	L	6	M12×1,5	27	12	14	Steel, galvanized	500	7 250	68	0.15
223-14190-7	TB.STUD ST EL 8-L CF	L	8	M14×1,5	29	12	17	Steel, galvanized	500	7 250	87	0.19
223-13040-9	TB.STUD ST EL 10-L CF	L	10	M16×1,5	30	14	19	Steel, galvanized	500	7 250	110	0.24
223-13761-5	TB.STUD ST EL 12-L CF	L	12	M18×1,5	32	17	22	Steel, galvanized	400	5 800	151	0.33
223-14190-5	TB.STUD ST EL 15-L CF	L	15	M22×1,5	36	19	27	Steel, galvanized	400	5 800	245	0.54
443-418-181	TB.STUD ST EL 18-L CF	L	18	M26×1,5	40	24	32	Steel, galvanized	400	5 800	369	0.81
223-13040-3	TB.STUD ST EL 6-S CF	S	6	M14×1,5	31	12	17	Steel, galvanized	800	11 600	103	0.23
223-13040-7	TB.STUD ST EL 8-S CF	S	8	M16×1,5	32	14	19	Steel, galvanized	800	11 600	130	0.29
223-14190-2	TB.STUD ST EL 10-S CF	S	10	M18×1,5	34	17	22	Steel, galvanized	800	11 600	136	0.30
223-14190-4	TB.STUD ST EL 12-S CF	S	12	M20×1,5	38	17	24	Steel, galvanized	630	9 140	212	0.47
223-14190-1	TB.STUD ST EL 16-S CF	S	16	M24×1,5	43	24	30	Steel, galvanized	630	9 140	404	0.89
223-13761-7	TB.STUD ST EL 20-S CF	S	20	M30×2	48	27	36	Steel, galvanized	420	6 090	601	1.33
Stainless steel												
223-14244-8	TB.STUD VA EL 10-L	L	10	M16×1,5	30	14	19	Stainless steel 1.4571	315	4 570	110	0.24
223-14244-6	TB.STUD VA EL 20-S	S	20	M30×2	48	27	36	Stainless steel 1.4571	400	5 800	601	1.33

### L-connectors EVL directionally adjustable

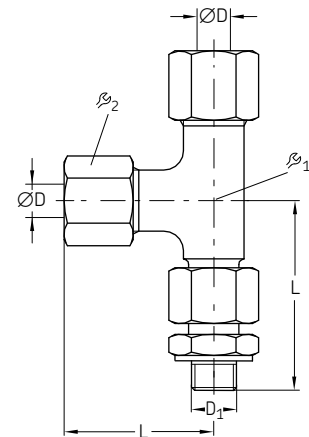

Order number	Designation	Series	Tube ØD	ØD <sub>1</sub>	L	β <sub>1</sub>	β <sub>2</sub>	Material	Operating pressure max.		Weight	
									bar	psi	g	lb
			mm	in	mm	mm	mm					
Steel, galvanized												
443-410-211	TB.FITT.ST EVL 10-S G3/8A CF	S	10	G 3/8	34	17	22	Steel, galvanized	630	9 140	226	0.50
443-410-161	TB.FITT.ST EVL 10-L G1/4A CF	L	10	G 1/4	30	14	19	Steel, galvanized	250	3 625	132	0.29

## Double-edged cutting sleeve unions

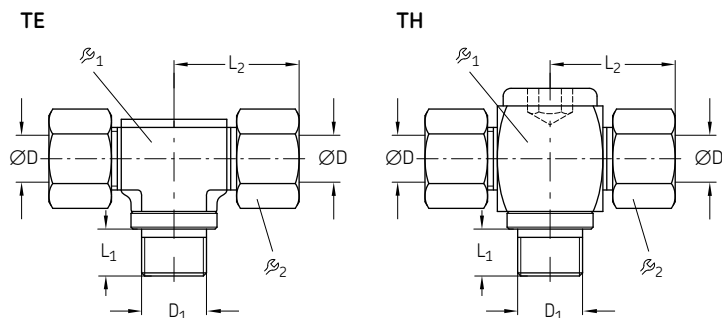
Screw-in T-connectors  
TE, TH with metrical  
pipe thread

Order number	Designation	Series	Tube ØD	D <sub>1</sub>	L <sub>1</sub>	L <sub>2</sub>	ϕ <sub>1</sub>	ϕ <sub>2</sub>	Material	Operating pressure max.		Weight	
										bar	psi	g	lb
				mm	mm	mm	mm	mm					
96-6404-0058	TB.FITT.ST TE 4-LL M 8x1,0K CF	LL	4	M8x1 tap.	8	21	9	10	Steel, galvanized	100	1 450	19	0.04
96-6406-0058	TB.FITT.ST TE 6-LL M10x1,0K CF	LL	6	M10x1 tap.	8	21	11	12	Steel, galvanized	100	1 450	40	0.09
96-6408-0058	TB.FITT.ST TE 8-LL M10x1,0K CF	LL	8	M10x1 tap.	8	23	12	14	Steel, galvanized	100	1 450	30	0.07
96-0906-0058	TB.FITT.ST TE 6-L M10x1,0xK CF	L	6	M10x1 tap.	8	27	12	14	Steel, galvanized	250	3 625	50	0.11
445-910-551	TB.FITT.ST TE10-L M14x1,5K CF	L	10	M14x1,5 tap.	12	30	14	19	Steel, galvanized	250	3 625	100	0.22
96-1806-0058	TB.FITT.ST TE 6-S M12x1,5K CF	S	6	M12x1,5 tap.	12	31	14	17	Steel, galvanized	400	5 800	67	0.15
96-1808-0058	TB.FITT.ST TE 8-S M14x1,5K CF	S	8	M14x1,5 tap.	12	32	14	19	Steel, galvanized	400	5 800	100	0.22
445-735-101	TB.FITT.ST TH10-L M14x1,5K CF	L	10	M14x1,5	12	30	19	19	Steel, galvanized	315	3 625	154	0.34
445-739-152	TB.FITT.ST TH15-L M18x1,5K CF	L	15	M18x1,5	14	37	30	32	Steel, galvanized	250	3 625	352	0.78

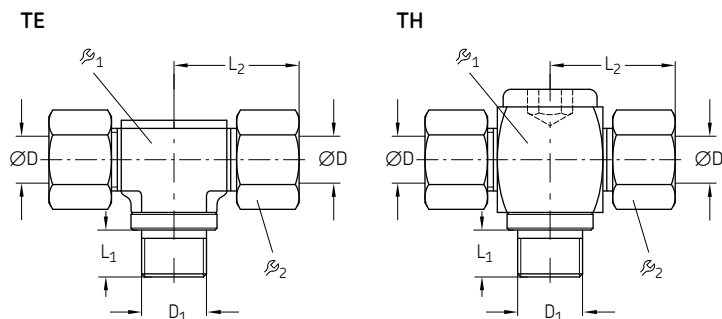
Screw-in T-connectors  
TE, TH with Whitworth  
pipe thread

Order number	Designation	Series	Tube ØD	D <sub>1</sub>	L <sub>1</sub>	L <sub>2</sub>	ϕ <sub>1</sub>	ϕ <sub>2</sub>	Material	Operating pressure max.		Weight	
										bar	psi	g	lb
				mm	in	mm	mm	mm					
96-6304-0058	TB.FITT.ST TE 4-LL R 1/8K CF	LL	4	R1/8	8	21	10	11	Steel, galvanized	100	1 450	14	0.03
96-6306-0058	TB.FITT.ST TE 6-LL R 1/8K CF	LL	6	R1/8	8	21	11	12	Steel, galvanized	100	1 450	26	0.06
96-6308-0058	TB.FITT.ST TE 8-LL R 1/8K CF	LL	8	R1/8	8	23	12	14	Steel, galvanized	100	1 450	32	0.07
96-0806-0058	TB.FITT.ST TE 6-L R 1/8K CF	L	6	R1/8	8	27	12	14	Steel, galvanized	250	3 625	38	0.08
96-0808-0058	TB.FITT.ST TE 8-L R 1/4K CF	L	8	R1/4	12	29	14	17	Steel, galvanized	250	3 625	75	0.17
96-0810-0058	TB.FITT.ST TE 10-L R 1/4K CF	L	10	R1/4	12	30	14	19	Steel, galvanized	250	3 625	100	0.22
96-0818-0058	TB.FITT.ST TE 18-L R 1/2K CF	L	18	R1/2	14	40	24	32	Steel, galvanized	250	3 625	149	0.33
96-1706-0058	TB.FITT.ST TE 6-S R 1/4K CF	S	6	R1/4	12	31	12	17	Steel, galvanized	400	5 800	100	0.22
445-721-121	TB.FITT.ST TH12-L G 3/8A CF	L	12	G 3/8A	12	33	24	22	Steel, galvanized	315	4 570	249	0.55
445-713-152	TB.FITT.ST TH 15-L G 1/2A CF	L	15	G 1/2A	14	37	30	27	Steel, galvanized	315	4 570	415	0.92
445-717-221	TB.FITT.ST TH 22-L G 3/4A CF	L	22	G 3/4A	16	44	36	36	Steel, galvanized	160	2 320	763	1.68

## Double-edged cutting sleeve unions

### Swivel nut branch ET

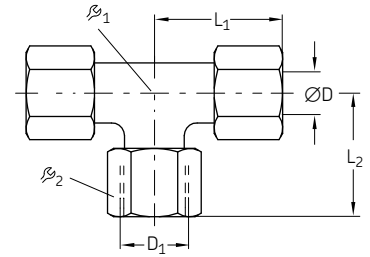

Order number	Designation	Series	Tube ØD	D <sub>1</sub>	L <sub>1</sub>	L <sub>2</sub>	β <sub>1</sub>	β <sub>2</sub>	Material	Operating pressure max.		Weight	
										bar	psi	g	lb
				mm	mm	mm	mm	mm					
223-14189-6	TB.STUD ST ET 6-L CF	L	6	M12×1,5	27	26	12	14	Steel, galvanized	500	7 250	68	0.15
223-13040-1	TB.STUD ST ET 8-L CF	L	8	M14×1,5	29	26,5	12	17	Steel, galvanized	500	7 250	87	0.19
223-14189-1	TB.STUD ST ET10-L CF	L	10	M16×1,5	30	29	14	19	Steel, galvanized	500	7 250	113	0.25
223-13785-8	TB.STUD ST ET12-L CF	L	12	M18×1,5	32	29,5	17	22	Steel, galvanized	400	5 800	153	0.34
223-14189-7	TB.STUD ST ET15-L CF	L	15	M22×1,5	36	32,5	19	27	Steel, galvanized	400	5 800	253	0.56
96-3118-0060	TB.STUD ST ET18-L CF	L	18	M26×1,5	40	35,5	24	32	Steel, galvanized	400	5 800	375	0.83
96-3122-0060	TB.STUD ST ET22-L CF	L	22	M30×1,5	44	38,5	27	36	Steel, galvanized	250	3 625	486	1.07
445-806-351	TB.STUD ST ET 6-S CF	S	6	M14×1,5	31	27	12	17	Steel, galvanized	800	11 600	101	0.22
223-10374-3	TB.STUD ST ET 8-S CF	S	8	M16×1,5	32	27,5	14	19	Steel, galvanized	800	11 600	135	0.30
223-14189-5	TB.STUD ST ET10-S CF	S	10	M18×1,5	34	30	17	22	Steel, galvanized	800	11 600	181	0.40
223-14189-9	TB.STUD ST ET12-S CF	S	12	M20×1,5	38	31	17	24	Steel, galvanized	630	9 140	212	0.47
223-14189-2	TB.STUD ST ET16-S CF	S	16	M24×1,5	43	36,5	24	30	Steel, galvanized	630	9 140	383	0.84
223-14189-3	TB.STUD ST ET20-S CF	S	20	M30×1,5	48	44,5	27	36	Steel, galvanized	420	6 090	614	1.35

### Swivel nut elbow EW

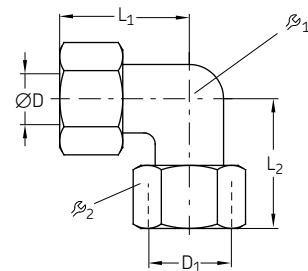

Order number	Designation	Series	Tube ØD	D <sub>1</sub>	L <sub>1</sub>	L <sub>2</sub>	β <sub>1</sub>	β <sub>2</sub>	Material	Operating pressure max.		Weight	
										bar	psi	g	lb
				mm	mm	mm	mm	mm					
223-14171-1	TB.STUD ST EW 6-L CF	L	6	M12×1,5	27	26	12	14	Steel, galvanized	500	7 250	46	0.10
223-14102-3	TB.STUD ST EW 8-L CF	L	8	M14×1,5	29	27,5	12	17	Steel, galvanized	500	7 250	59	0.13
443-306-343	TB.STUD ST EW 6-S CF	S	6	M14×1,5	31	27	12	17	Steel, galvanized	800	11 600	67	0.15
223-14171-8	TB.STUD ST EW10-S CF	S	10	M18×1,5	34	30	17	22	Steel, galvanized	800	11 600	126	0.28
223-14171-4	TB.STUD ST EW16-S CF	S	16	M24×1,5	43	36,5	24	30	Steel, galvanized	630	9 140	284	0.63
223-14171-5	TB.STUD ST EW20-S CF	S	20	M30×1,5	48	44,5	27	36	Steel, galvanized	420	6 090	422	0.93

## Double-edged cutting sleeve unions

## Swivels DVWE

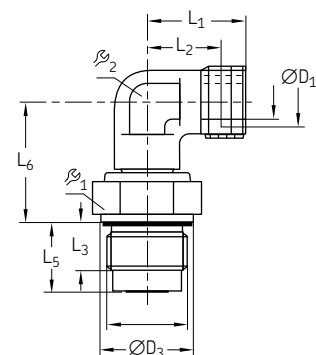

Order number	Designation	Tube Ø	Ø D <sub>1</sub>	Series	Speed max.	Operation pressure		Material	Weight	
						bar	psi		g	lb
		mm	in		min <sup>-1</sup>					
Steel galvanized										
223-13694-6	TB.FITT.ST DVWE10-L G 3/8A CF 10	10		G 3/8A L	21	40	580	Steel galvanized	83	0.18
223-13694-1	TB.FITT.ST DVWE10-S G 3/8A CF 10	10		G 3/8A S	9	100	1 450	Steel galvanized	103	0.23
Stainless steel										
223-13694-7	TB.FITT.VA DVWE10-L G 3/8A	10		G 3/8A L	21	40	580	Stainless steel 1.4571	83	0.18
223-13694-3	TB.FITT.VA DVWE10-S G 3/8A	10		G 3/8A S	9	100	1 450	Stainless steel 1.4404	103	0.23

## Swivels DG

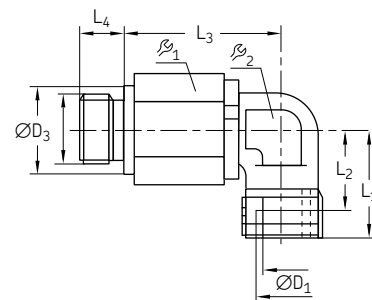

Order number	Designation	Tube Ø	Ø D <sub>1</sub>	Series	Speed max.	Operation pressure		Material	Weight	
						bar	psi		g	lb
		mm	in		min <sup>-1</sup>					
223-13665-7	TB.FITT.ST DG104/6-S G 1/4A CF 6	6		G 1/4A S	400	100	1 450	Steel galvanized	131	0.29
223-13665-8	TB.FITT.ST DG104/8-S G 1/4A CF 8	8		G 1/4A S	400	100	1 450	Steel galvanized	135	0.30
223-13665-9	TB.FITT.ST DG104/12-S G 3/8A CF 12	12		G 3/8A S	200	100	1 450	Steel galvanized	284	0.62



## Double-edged cutting sleeve unions

# Blanking plug for cones BUZ

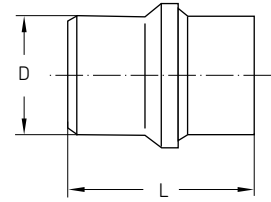

Order number	Designation	Series	D	L	Material	Operating pressure max.		Weight		
			mm	mm		bar	psi	g	lb	
Steel galvanized										
<b>223-13640-1</b>	PLUG ST BUZ 6-L/S CF	L/S	6	19,5	Steel, galvanized	315	4 570	5	0.01	
<b>223-13640-5</b>	PLUG ST BUZ 8-L/S CF	L/S	8	19,5	Steel, galvanized	315	4 570	8	0.02	
<b>223-13640-3</b>	PLUG ST BUZ10 -L/S CF	L/S	10	21,0	Steel, galvanized	315	4 570	13	0.03	
<b>223-13640-4</b>	PLUG ST BUZ12 -L/S CF	L/S	12	21,8	Steel, galvanized	315	4 570	20	0.04	
<b>223-13640-8</b>	PLUG ST BUZ16 -S CF	S	16	25,5	Steel, galvanized	400	5 800	39	0.09	
<b>223-13640-2</b>	PLUG ST BUZ20 -S CF	S	20	30,5	Steel, galvanized	400	5 800	73	0.16	
Stainless steel										
<b>223-14215-5</b>	PLUG VA BUZ 6-L/S	L/S	6	19,5	Stainless steel 1.4571	315	4 570	5	0.01	
<b>223-14215-3</b>	PLUG VA BUZ10 -L/S	L/S	10	21,0	Stainless steel 1.4571	315	4 570	13	0.03	
<b>223-14215-2</b>	PLUG VA BUZ12 -L/S	L/S	12	21,8	Stainless steel 1.4571	315	4 570	20	0.04	
<b>223-13640-9</b>	PLUG VA BUZ18 -L	L	18	24,0	Stainless steel 1.4571	315	4 570	45	0.10	
<b>223-14215-4</b>	PLUG VA BUZ20 -S	S	20	30,5	Stainless steel 1.4571	400	5 800	73	0.16	

## Soft-seal cutting sleeve union (SSCS)

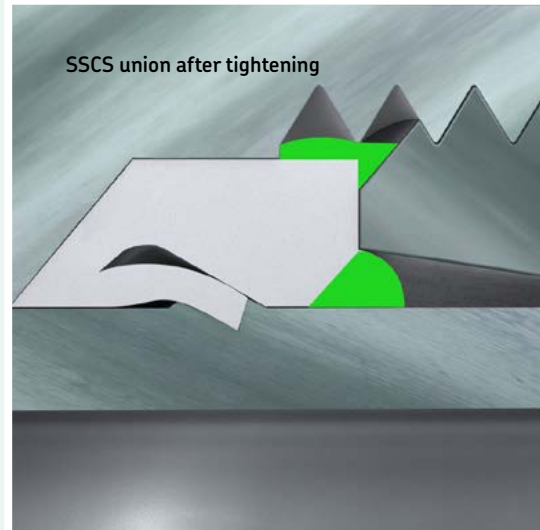
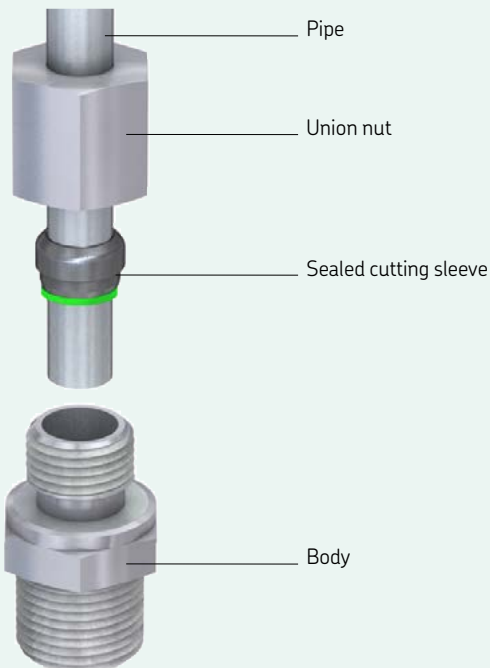

### Description

Soft-seal cutting sleeve unions (SSCS) consist of a union nut, a cutting sleeve, a support ring with soft seal, and a body with another soft seal. To mount the union, the union nut and the sealed cutting sleeve have to be put on the pipe end. All parts must be aligned as shown on the illustration above. Then the pipe end can be pushed into the body before tightening the union nut. During that process, the sealed cutting sleeve cuts into the pipe to seal the connection as shown in the illustration above. In addition, the union also is sealed by the soft seal.

### Features and benefits

- Compact installation dimensions
- Virtually leakage-free, high-pressure union
- Recommended for high-pressure oil and grease applications
- Common fitting system for high-pressure systems
- Higher nominal pressures than DECS unions (series "L" can often be used instead of "S")
- High sealing capacity, especially with low-viscosity media (e.g. no sweating with low-viscosity oils)
- Easy assembly by tightening the union nut to the stop (no risk of under- or over-assembly)
- Pipe vibration dampening resulting from pipe fixation during assembly (caused by SSCS union)
- Wide operating temperature range from -25 to 80 °C
- Tightening forces 25% lower than TECS unions

## Soft-seal cutting sleeve union

# Straight screw-in connectors GE

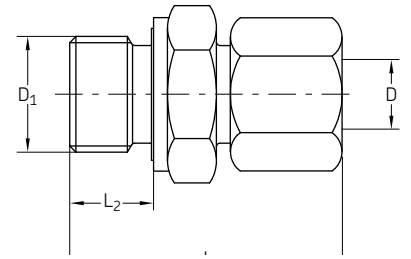

Order number	Designation	Series	Tube ØD	ØD <sub>1</sub>	L	L <sub>1</sub>	R <sub>1</sub>	R <sub>2</sub>	Material	Operating pressure max.		Weight	
										bar	psi	g	lb
				mm	mm	mm	mm	mm					
471-004-191	TB.FITT.ST GE 4-LL G 1/8A-ED CF	LL	4	G 1/8A	19	6,5	14	10	Steel galv.	100	1 450	15	0.03
471-004-311	TB.FITT.ST GE 4-LL M 10x1,0-ED CF	LL	4	M10x1	26	8	10	10	Steel galv.	100	1 450	15	0.03
471-006-192	TB.FITT.ST GE 6-L G 1/8A-ED CF	L	6	G 1/8A	23	8	14	14	Steel galv.	500	7 250	25	0.06
471-006-161	TB.FITT.ST GE 6-L G 1/4A-ED CF	L	6	G 1/4A	25	12	19	14	Steel galv.	500	7 250	40	0.09
471-006-311	TB.FITT.ST GE 6-L M 10x1,0-ED CF	L	6	M10x1	23	8	14	14	Steel galv.	500	7 250	25	0.06
471-006-351	TB.FITT.ST GE 6-L M 14x1,5-ED CF	L	6	M14x1,5	27	12	14	14	Steel galv.	400	5 800	44	0.10
471-008-130	TB.FITT.ST GE 8-L G 1/8A-ED CF	L	8	G 1/8A	24	8	14	17	Steel galv.	500	7 250	33	0.07
471-008-161	TB.FITT.ST GE 8-L G 1/4A-ED CF	L	8	G 1/4A	25	12	19	17	Steel galv.	500	7 250	44	0.10
471-008-131	TB.FITT.ST GE 8-L G 1/2A-ED CF	L	8	G 1/2A	27	14	27	17	Steel galv.	400	5 800	90	0.20
471-008-211	TB.FITT.ST GE 8-L G 3/8A-ED CF	L	8	G 3/8A	26	12	22	17	Steel galv.	400	5 800	60	0.13
471-008-314	TB.FITT.ST GE 8-L M 10x1,0-ED CF	L	8	M10x1	34	7	17	14	Steel galv.	45	650	40	0.09
471-008-345	TB.FITT.ST GE 8-L M 12x1,5-ED CF	L	8	M12x1,5	25	12	17	17	Steel galv.	500	7 250	37	0.08
471-008-391	TB.FITT.ST GE 8-L M 18x1,5-ED CF	L	8	M18x1,5	38	11	24	17	Steel galv.	400	5 800	70	0.15
471-010-161	TB.FITT.ST GE 10-L G 1/4A-ED CF	L	10	G 1/4A	26	12	19	19	Steel galv.	500	7 250	50	0.11
471-010-211	TB.FITT.ST GE 10-L G 3/8A-ED CF	L	10	G 3/8A	27	12	22	22	Steel galv.	400	5 800	60	0.13
471-010-312	TB.FITT.ST GE 10-L M 10x1,0-ED CF	L	10	M10x1	32	8	19	17	Steel galv.	500	7 250	43	0.09
471-010-351	TB.FITT.ST GE 10-L M 14x1,5-ED CF	L	10	M14x1,5	26	12	19	19	Steel galv.	500	7 250	50	0.11
471-010-391	TB.FITT.ST GE 10-L M 18x1,5-ED CF	L	10	M18x1,5	27	12	24	19	Steel galv.	400	5 800	75	0.17
471-012-161	TB.FITT.ST GE 12-L G 1/4A-ED CF	L	12	G 1/4A	27	12	19	22	Steel galv.	400	5 800	58	0.13
471-012-211	TB.FITT.ST GE 12-L G 3/8A-ED CF	L	12	G 3/8A	27	12	22	22	Steel galv.	400	5 800	73	0.16
471-012-391	TB.FITT.ST GE 12-L M 18x1,5-ED CF	L	12	M18x1,5	27	12	24	22	Steel galv.	400	5 800	120	0.26
471-008-351	TB.FITT.ST GE 8-S M 14x1,5-ED CF	S	8	M14x1,5	30	12	19	19	Steel galv.	400	5 800	50	0.11

## Cone plugs VKA

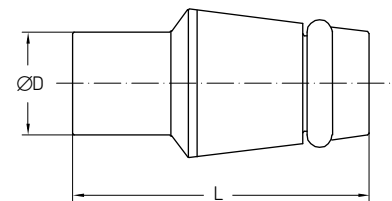

Order number	Designation	Series	Tube ØD	L	Material	Operating pressure max.		Weight		
						bar	psi	g	lb	
				mm	mm					
Steel galvanized										
223-10297-5	BLANKING PLUG ST VKA 6-L/S CF	L/S	6	18,5	Steel galvanized	800	11 600	6	0.01	
460-708-001	BLANKING PLUG ST VKA 8-L CF	L	8	18,5	Steel galvanized	500	7 250	9	0.02	
223-10297-6	BLANKING PLUG ST VKA10-L/S CF	L/S	10	15	Steel galvanized	800	11 600	15	0.03	
223-10297-7	BLANKING PLUG ST VKA20-S CF	S	20	28,5	Steel galvanized	420	6 090	78	0.17	
223-14241-2	BLANKING PLUG ST VKA30-S CF	S	30	30,5	Steel galvanized	420	6 090	180	0.40	
Stainless steel										
223-14241-9	BLANKING PLUG VA VKA10-L/S	L/S	10	15	Stainless steel 1.4571	630	9 140	15	0.03	
223-14241-5	BLANKING PLUG VA VKA30-S	S	30	30,5	Stainless steel 1.4571	400	5 800	180	0.40	

## Soft-seal cutting sleeve union

## Straight screw-in connectors with shortened thread and function nut GE (short)

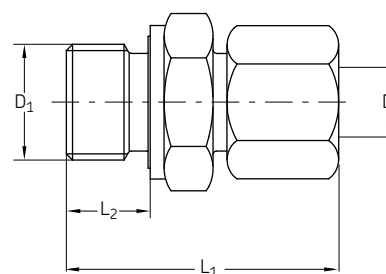

Order number	Designation	Series	Tube ØD	ØD <sub>1</sub>	L <sub>1</sub>	L <sub>2</sub>	R <sub>1</sub>	R <sub>2</sub>	Material	Operating pressure max.		Weight	
										bar	psi	g	lb
471-006-320	TB.FITT.ST GE 6-LL M10x1,0-ED CF SHORT	LL	6	M10x1	31	7	14	14	Steel galv.	100	1 450	27	0.06
471-006-319	TB.FITT.ST GE 6-LL M12x1,0-ED CF SHORT	LL	6	M12x1	31	7	14	19	Steel galv.	100	1 450	40	0.09
471-008-132	TB.FITT.ST GE 8-LL M10x1,0-ED CF SHORT	LL	8	M10x1	34	7	17	14	Steel galv.	100	1 450	35	0.08
471-008-318	TB.FITT.ST GE 8-LL M12x1,0-ED CF SHORT	LL	8	M12x1	32	7	17	19	Steel galv.	100	1 450	70	0.15
471-010-312	TB.FITT.ST GE10-LL M10x1,0-ED CF SHORT	LL	10	M10x1	32	7	19	17	Steel galv.	100	1 450	43	0.09
471-010-318	TB.FITT.ST GE10-LL M12x1,0-ED CF SHORT	LL	10	M12x1	34	7	19	19	Steel galv.	100	1 450	45	0.10
471-012-312	TB.FITT.ST GE12-LL M10x1,0-ED CF SHORT	LL	12	M10x1	36	7	22	22	Steel galv.	100	1 450	57	0.13

## Straight bulkhead connectors with function nut SVZ

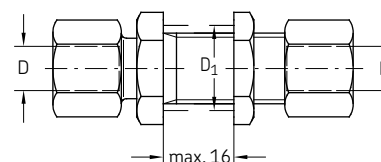

Order number	Designation	Series	Tube ØD	D <sub>1</sub>	L <sub>1</sub>	L <sub>2</sub>	R <sub>1</sub>	R <sub>2</sub>	R <sub>3</sub>	Material	Operating pressure max.		Weight	
											bar	psi	g	lb
474-606-331	TB.FITT.ST SV 6-L CF	L	6	12,5	22	42	17	17	14	Steel galv.	500	7 250	61	0.13
474-608-351	TB.FITT.ST SV 8-L CF	L	8	14,5	23	42	19	19	17	Steel galv.	500	7 250	83	0.18
474-610-351	TB.FITT.ST SV10-L CF	L	10	16,5	25	43	22	22	19	Steel galv.	500	7 250	100	0.22
474-612-391	TB.FITT.ST SV12-L CF	L	12	18,5	25	44	24	24	22	Steel galv.	400	5 800	134	0.30
474-615-431	TB.FITT.ST SV15-L CF	L	15	22,5	27	46	27	30	27	Steel galv.	400	5 800	224	0.49
474-618-441	TB.FITT.ST SV18-L CF	L	18	26,5	30	49	32	36	32	Steel galv.	400	5 800	344	0.76

## Soft-seal cutting sleeve union

### Straight connectors (tube to tube) with function nut GZ

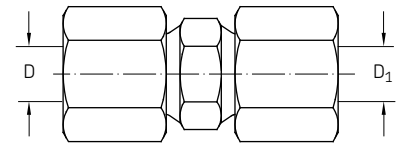

Order number	Designation	Series	Tube ØD	L	⌀	Material	Operating pressure max.		Weight	
							bar	psi	g	lb
<b>474-506-061</b>	TB.FITT.ST G 6Z-L CF	L	6	39	14	Steel galvanized	500	7 250	35	0.08
<b>474-508-081</b>	TB.FITT.ST G 8Z-L CF	L	8	40	17	Steel galvanized	500	7 250	50	0.11
<b>474-510-101</b>	TB.FITT.ST G10Z-L CF	L	10	42	19	Steel galvanized	500	7 250	64	0.14
<b>474-512-121</b>	TB.FITT.ST G12Z-L CF	L	12	43	22	Steel galvanized	400	5 800	87	0.19
<b>474-515-151</b>	TB.FITT.ST G15Z-L CF	L	15	46	27	Steel galvanized	400	5 800	144	0.32
<b>474-518-181</b>	TB.FITT.ST G18Z-L CF	L	18	48	32	Steel galvanized	400	5 800	200	0.44

### T-connectors with function nut TZ

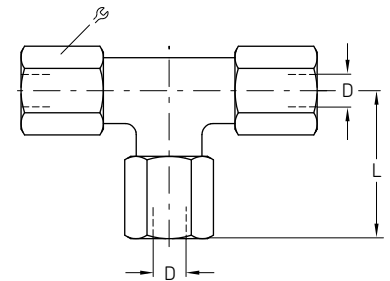

Order number	Designation	Series	Tube ØD	L	⌀	Material	Operating pressure max.		Weight	
							bar	psi	g	lb
<b>476-006-001</b>	TB.FITT.ST T 6Z-L CF	L	6	27	14	Steel galvanized	500	7 250	70	0.15
<b>476-008-001</b>	TB.FITT.ST T 8Z-L CF	L	8	29	17	Steel galvanized	500	7 250	90	0.20
<b>476-010-001</b>	TB.FITT.ST T10Z-L CF	L	10	30	19	Steel galvanized	500	7 250	114	0.25
<b>476-012-001</b>	TB.FITT.ST T12Z-L CF	L	12	32	22	Steel galvanized	400	5 800	153	0.34
<b>476-015-001</b>	TB.FITT.ST T15Z-L CF	L	15	36	27	Steel galvanized	400	5 800	241	0.53

## Adapters, plugs and washers



### Description

Adapter fittings are used where no standard fittings are available or may require too much space. In fact, adapter fittings are not an ideal solution due to the risk of an additional leakage point in the system. Therefore, the adapter fitting sealing, material, design and operation pressure must be considered during the selection process. SKF offers adapters for various applications with suitable operating pressures, fittings, seals and designs.

Adapter fittings, plugs and washers are available in various designs to serve different application requirements for system pressure:

- 45 bar designs
- 350 bar designs
- LL (very light, max. 100 bar)
- L (light, max. 500 bar)
- S (heavy, max. 800 bar)

### Features and benefits

- Fast and virtually leakage-free connection
- Designs for almost every application
- Space-saving small design



## Applications

- Food and beverage industry
- Renewable energy industry
- Construction machinery
- Material handling
- On-road vehicles
- Machine tools
- Etc.

## Adapter fittings

Reducing connectors with cylindrical thread for operating pressures up to 45 bar (sealed by flat washer acc. to DIN 7603)

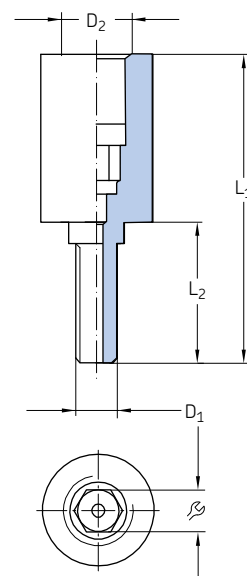

Order number	Designation	D <sub>1</sub>	D <sub>2</sub>	L <sub>1</sub>	L <sub>2</sub>	♀	Material	Weight	
								mm	mm
843-130-021	ADAPTER ST M 3Ax M 5I CF	M3	M5	22	10	3 <sup>1)</sup>	Steel, galvanized surface	4	0.01
843-130-022	ADAPTER ST M 4Ax M 5I CF	M4	M5	22	10	3 <sup>1)</sup>	Steel, galvanized surface	5	0.01
843-130-023	ADAPTER ST M 5Ax M 5I CF	M5	M5	22	10	3 <sup>1)</sup>	Steel, galvanized surface	11	0.02

<sup>1)</sup> Female thread

Reducing connectors with tapered thread for operating pressures up to 45 bar

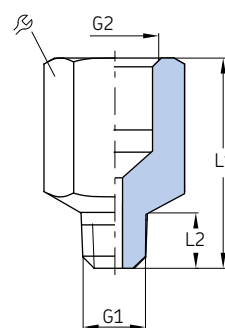

Order number	Designation	G <sub>1</sub>	G <sub>2</sub>	L <sub>1</sub>	L <sub>2</sub>	♀	Material	Weight	
								mm	in
406-044-S1	ADAPTER ST M10x1AKx R1/4I CF	M10x1 tap.	R 1/4	22,5	8	17	Steel, galvanized surface	20	0.04



## Adapter fittings

# Reducing connectors with cylindrical thread for operating pressures up to 45 bar (sealed by flat washer acc. to DIN 7603)

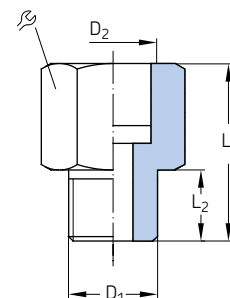

Order number	Designation	D <sub>1</sub>	D <sub>2</sub>	L <sub>1</sub>	L <sub>2</sub>	⌀	Material	Weight	
								g	lb
			in	mm	mm	mm			
Steel, galvanized surface									
401-013-161	ADAPTER ST G1/4Ax G1/2 CF	G 1/4 A	G 1/2	40	12	27	Steel, galvanized	114	0.25
401-011-132	ADAPTER ST G1/2Ax G1 CF	G 1/2 A	G 1	49	14	41	Steel, galvanized	222	0.49
401-013-171	ADAPTER ST G1/4Ax G1/2 CF	G 3/4 A	G 1/2	41	16	32	Steel, galvanized	140	0.31
P-78.01	ADAPTER ST M12x1Ax G1/4 CF	M12x1	G 1/4	27	8,5	19	Steel, galvanized	31	0.07
401-016-371	ADAPTER ST M16x1,5Ax G1/4 CF	M16x1,5	G 1/4	30	12	19	Steel, galvanized	39	0.09
243-001.10	ADAPTER ST M16x1,5Ax G1/2 CF	M16x1,5	G 1/2	31	9	27	Steel, galvanized	60	0.13
267-001.36	ADAPTER ST M18x1,5Ax G3/8 CF	M18x1,5	G 3/8	32	10	22	Steel, galvanized	50	0.11
243-001.20	ADAPTER ST M18x1,5Ax G1/2 CF	M18x1,5	G 1/2	32	10	27	Steel, galvanized	59	0.13
44-1755-2029	ADAPTER ST M20x1,5Ax G1/4 CF	M20x1,5	G 1/4	28	12	24	Steel, galvanized	59	0.13
Brass									
267-001.47	ADAPTER MS G3/8Ax G3/4	G 3/8 A	G 1/4	31	10	22	Brass	60	0.13
267-001.60	ADAPTER MS G3/8Ax G1/2	G 3/8 A	G 1/2	34	10	27	Brass	78	0.17
401-019-132	ADAPTER MS G1/2Ax G1/8	G 1/2 A	G 1/8	24	12	27	Brass	22	0.05
DZ333	ADAPTER MS G1/2Ax G1/4	G 1/2 A	G 1/4	24	12	27	Brass	64	0.14
401-013-131	ADAPTER MS G1/2Ax G1/2	G 1/2 A	G 1/2	40,5	12	27	Brass	107	0.24
DZ334	ADAPTER MS G1/2Ax G3/8	G 1/2 A	G 3/8	31	12	27	Brass	83	0.18
267-001.03	ADAPTER MS G1/2Ax G3/4	G 1/2 A	G 3/4	40	12	36	Brass	166	0.37
406-024	ADAPTER MS M10x1Ax G1/8	M10x1	G 1/8	20	8	14	Brass	15	0.03
401-016-312	ADAPTER MS M10x1Ax G1/4	M10x1	G 1/4	26,5	7,5	17	Brass	25	0.06
401-019-352	ADAPTER MS M14x1,5Ax G1/8	M14x1,5	G 1/8	20	9	17	Brass	24	0.05

# Adapter for pressure gauges for operating pressures up to 45 bar (sealed by flat washer acc. to DIN 7603)

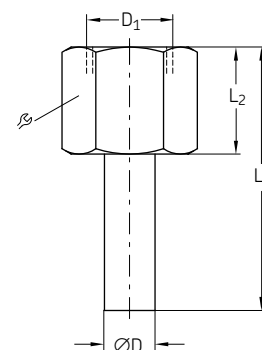

Order number	Designation	Series	Tube ØD	D <sub>1</sub>	L <sub>1</sub>	L <sub>2</sub>	⌀	Material	Operating pressure max.		Weight	
									bar	psi	g	lb
			mm	in	mm	mm	mm					
248-610.01	ADAPTER MS D 6AxG 1/4	L	6	G 1/4	46	22	17	Brass	45	650	30	0.07

## Adapter fittings

# Adapter for pressure gauges with cylindrical thread for operating pressures up to 45 bar

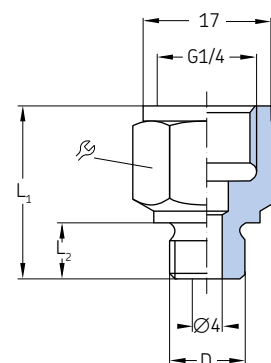

Order number	Designation	D	L <sub>1</sub>	L <sub>2</sub>	⌀	Material	Weight	
							mm	mm
301-134	CONNECTING PIECE ST - M10×1 ZN	M10×1	23	7,5	17	Steel, galvanized	20	0.044
301-034	CONNECTING PIECE ST - M14×1,5 ZN	M14×1,5	22	9	17	Steel, galvanized	20	0.044

# Reducing connectors with tapered thread for operating pressures up to 350 bar

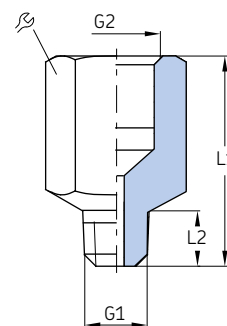

Order number	Designation	G <sub>1</sub>	G <sub>2</sub>	L <sub>1</sub>	L <sub>2</sub>	⌀	Material	Weight	
								mm	mm
304-19230-1	ADAPTER R1/8 AxM10x1,0   CF	R1/8	M10×1	18	6	13	Steel, galvanized	20	0.04
304-19787-1	ADAPTER M 8X1,0 IXM 6X1,0KA CF	M 6×1K	M 8×1	20	6	10	Steel, galvanized	6	0.01
304-19437-1	ADAPTER M 8x1,0KAxM 8x1,0   CF	M 8×1K	M 8×1	16	5	10	Steel, galvanized	5	0.01
304-19548-1	ADAPTER M 8x1,25KAxM 8x1,0   CF	M 8×1,25K	M 8×1	20	8	12	Steel, galvanized	10	0.02
304-19167-1	ADAPTER M 8x1,0KAxG1/8   CF	M 8×1K	G1/8	17	5	13	Steel, galvanized	10	0.02
304-19509-1	ADAPTER M10x1,0KAxM10x1,0   CF	M10×1K	M10×1	18	6,5	13	Steel, galvanized	9	0.02
304-16337-1	ADAPTER M10x1   xM12x1KA CF	M12×1K	M10×1	18	8	17	Steel, galvanized	15	0.03

## Adapter fittings

### Elbow reducing connectors 45° with tapered thread for operating pressures up to 350 bar

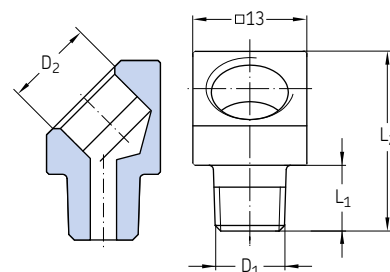

Order number	Designation	D <sub>1</sub>	D <sub>2</sub>	L <sub>1</sub>	L <sub>2</sub>	Material	Weight	
				mm	mm		g	lb
432-70673-1	ELBOW FITT.ST 45DEGREE R1/8A xG1/8 CF	R 1/8	G 1/8	6	20	Steel, galvanized	10	0.02
406-155K	ELBOW FITT.ST 45DEGREE R1/8AxM10x1I CF	R 1/8	M10x1	7,5	20,5	Steel, galvanized	13	0.03
406-165K	ELBOW FITT.ST 45DEGREE R1/8AxG1/8 CF	R 1/8	G 1/8	7,5	20,5	Steel, galvanized	13	0.03
432-24050-1	ELBOW FITT.ST 45DEGREE M8x1AKxM8x1I CF	M8x1 tap.	M8x1	5	20	Steel, galvanized	11	0.02
432-71483-1	ELBOW FITT.ST 45DEGREE M8x1AKxM10x1I CF	M8x1 tap.	M10x1	5	20	Steel, galvanized	11	0.02
406-145K	ELBOW FITT.ST 45DEGREE M8x1AKxM10x1I CF	M8x1 tap.	M10x1	7,5	21	Steel, galvanized	11	0.02
406-045K	ELBOW FITT.ST 45DEGREE M10x1AKxM10x1I CF	M10x1 tap.	M10x1	7,5	21	Steel, galvanized	12	0.03
432-24051-1	ELBOW FITT.ST 45DEGREE M10x1AKxM8x1I CF	M10x1 tap.	M8x1	5	20	Steel, galvanized	12	0.03

### Elbow reducing connectors 90° with tapered thread for operating pressures up to 350 bar

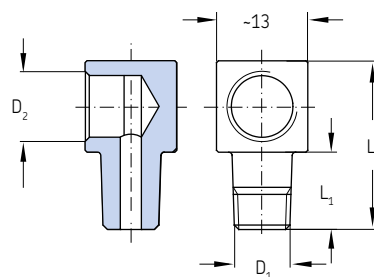

Order number	Designation	D <sub>1</sub>	D <sub>2</sub>	L <sub>1</sub>	L <sub>2</sub>	Material	Weight	
				mm	mm		g	lb
432-70674-1	ELBOW FITT.ST 90DEGREE G1/8xR1/8A CF	R 1/8	G 1/8	9	22.5	Steel, galvanized	16	0.04
406-091K	ELBOW FITT.ST 90DEGREE R1/8AxG1/8 CF	R 1/8	G 1/8	11	24	Steel, galvanized	20	0.04
406-093K	ELBOW FITT.ST 90DEGREE R1/8AxM10x1I CF	R 1/8	M10x1	11	24	Steel, galvanized	16	0.04
406-094K	ELBOW FITT.ST 90DE.M8x1,25AKxM8x1,25I CF	M8x1.25 tap.	M8x1.25	11	24	Steel, galvanized	11	0.02
406-089K	ELBOW FITT.ST 90DEGREE M8x1AKxM10x1I CF	M8x1 tap.	M10x1	11	24	Steel, galvanized	15	0.03
406-090K	ELBOW FITT.ST 90DEGREE M10x1AKxM10x1I CF	M10x1 tap.	M10x1	11	24	Steel, galvanized	16	0.04
406-092K	ELBOW FITT.ST 90DEGREE M10x1AKxM10x1I CF	M10x1 tap.	M10x1	17	30	Steel, galvanized	20	0.04
432-24043-1	ELBOW FITT.ST 90DEGREE M8x1AKxM8x1I CF	M8x1 tap.	M8x1	5	20	Steel, galvanized	12	0.03
432-24052-1	ELBOW FITT.ST 90DEGREE M10x1AKxM8x1I CF	M10x1 tap.	M8x1	5	20	Steel, galvanized	14	0.03

## Adapter fittings

# Reducing connectors RI with cylindrical thread for operating pressures up to 400 bar

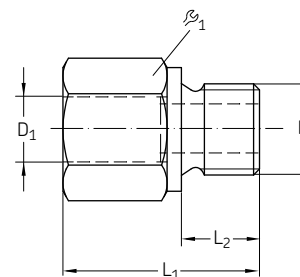

Order number	Designation	Tube ØD	ØD <sub>1</sub>	L <sub>1</sub>	L <sub>2</sub>	R	Material	Operating pressure max.		Weight	
								bar	psi	g	lb
		in	in	mm	mm	mm					
Steel galvanized											
222-12578-5	BUSHING ST RI G 1/8AxG 1/4 CF	G 1/8A	G 1/4	31	8	19	Steel galvanized	400	5 800	42	0.09
222-12521-5	BUSHING ST RI G 1/4AxG 1/8 CF	G 1/4A	G 1/8	28	12	19	Steel galvanized	400	5 800	38	0.08
222-12521-6	BUSHING ST RI G 1/4AxG 3/8 CF	G 1/4A	G 3/8	36	12	24	Steel galvanized	400	5 800	69	0.15
222-12521-4	BUSHING ST RI G 1/4AxG 1/2 CF	G 1/4A	G 1/2	40	12	30	Steel galvanized	400	5 800	116	0.26
222-13678-2	BUSHING ST RI G 3/8AxG 1/8 CF	G 3/8A	G 1/8	22.5	12	22	Steel galvanized	400	5 800	39	0.09
222-12578-4	BUSHING ST RI G 3/8AxG 1/4 CF	G 3/8A	G 1/4	36	12	22	Steel galvanized	400	5 800	68	0.15
222-12578-8	BUSHING ST RI G 3/8AxG 1/2 CF	G 3/8A	G 1/2	41	12	30	Steel galvanized	400	5 800	125	0.28
222-12578-3	BUSHING ST RI G 3/8AxG 3/4 CF	G 3/8A	G 3/4	44	12	36	Steel galvanized	315	4 570	183	0.40
222-12521-2	BUSHING ST RI G 1/2AxG 1/4 CF	G 1/2A	G 1/4	24	14	27	Steel galvanized	315	4 570	56	0.12
96-3102-0058	BUSHING ST RI G 1/2AxG 1/8 CF	G 1/2A	G 1/8	24	14	27	Steel galvanized	400	5 800	66	0.15
222-12599-2	BUSHING ST RI G 1/2AxG 3/8 CF	G 1/2A	G 3/8	36	14	27	Steel galvanized	315	4 570	94	0.21
222-12047-2	BUSHING ST RI G 1/2AxG 3/4 CF	G 1/2A	G 3/4	46	14	36	Steel galvanized	315	4 570	182	0.40
222-12599-3	BUSHING ST RI G 1/2AxG 1 CF	G 1/2A	G 1	49	14	41	Steel galvanized	315	4 570	221	0.49
222-13678-1	BUSHING ST RI G 3/4AxG 1/4 CF	G 3/4A	G 1/4	26	16	32	Steel galvanized	315	4 570	103	0.23
222-12578-9	BUSHING ST RI G 3/4AxG 3/8 CF	G 3/4A	G 3/8	26	16	32	Steel galvanized	315	4 570	87	0.19
222-12047-8	BUSHING ST RI G 3/4AxG 1/2 CF	G 3/4A	G 1/2	41	16	32	Steel galvanized	315	4 570	143	0.32
222-12047-4	BUSHING ST RI G 3/4AxG 1 CF	G 3/4A	G 1	51	16	41	Steel galvanized	315	4 570	235	0.52
96-3129-0058	BUSHING ST RI G 3/4AxG 1-1/4 CF	G 3/4A	G 1 1/4	55	16	55	Steel galvanized	160	2 320	481	1.06
222-12599-9	BUSHING ST RI G 1AxG 1/2 CF	G 1A	G 1/2	29	18	41	Steel galvanized	315	4 570	157	0.35
222-13678-4	BUSHING ST RI G 1AxG 3/8 CF	G 1A	G 3/8	29	18	41	Steel galvanized	315	4 570	179	0.39
96-3106-0058	BUSHING ST RI G 1AxG 1/4 CF	G 1A	G 1/4	29	18	41	Steel galvanized	315	4 570	195	0.43
222-12599-5	BUSHING ST RI G 1AxG 3/4 CF	G 1A	G 3/4	47	18	41	Steel galvanized	315	4 570	278	0.61
222-13670-1	BUSHING ST RI G 1AxG 1-1/4 CF	G 1A	G 1 1/4	57	18	55	Steel galvanized	160	2 320	530	1.17
96-3133-0058	BUSHING ST RI G 1AxG 1-1/2 CF	G 1A	G 1 1/2	59	18	60	Steel galvanized	160	2 320	585	1.29
222-13678-8	BUSHING ST RI G 1-1/4AxG 1/2 CF	G 1 1/4A	G 1/2	32	20	50	Steel galvanized	160	2 320	308	0.68
222-12521-8	BUSHING ST RI G 1-1/4AxG 3/4 CF	G 1 1/4A	G 3/4	32	20	50	Steel galvanized	160	2 320	267	0.59
222-12599-6	BUSHING ST RI G 1-1/4AxG 1 CF	G 1 1/4A	G 1	32	20	50	Steel galvanized	160	2 320	458	1.01
96-3112-0058	BUSHING ST RI G 1-1/2AxG 3/4 CF	G 1 1/2A	G 3/4	36	22	55	Steel galvanized	160	2 320	402	0.89
222-13678-3	BUSHING ST RI G 1-1/2AxG 1 CF	G 1 1/2A	G 1	36	22	55	Steel galvanized	160	2 320	337	0.74
96-3136-0058	BUSHING ST RI G 1-1/2AxG 1-1/4 CF	G 1 1/2A	G 1 1/4	58	22	55	Steel galvanized	160	2 320	542	1.20
96-3137-0058	BUSHING ST RI G 2AxG 1-1/2 CF	G 2A	G 1 1/2	62	24	70	Steel galvanized	160	2 320	990	2.18
Stainless steel											
222-13618-1	BUSHING VA RI G 1/8AxG 1/4	G 1/8A	G 1/4	31	8	19	Stainless steel 1.4571	400	5 800	42	0.09
222-10365-3	BUSHING VA RI G 1/4AxG 1/8	G 1/4A	G 1/8	28	12	19	Stainless steel 1.4571	400	5 800	38	0.08
222-13618-5	BUSHING VA RI G 1/4AxG 1/2	G 1/4A	G 1/2	40	12	30	Stainless steel 1.4571	400	5 800	116	0.26
222-14180-7	BUSHING VA RI G 3/8AxG 1/4	G 3/8A	G 1/4	36	12	22	Stainless steel 1.4571	400	5 800	68	0.15
222-13618-2	BUSHING VA RI G 3/8AxG 1/2	G 3/8A	G 1/2	41	12	30	Stainless steel 1.4571	400	5 800	125	0.28
222-14180-3	BUSHING VA RI G 1/2AxG 1/4	G 1/2A	G 1/4	24	14	27	Stainless steel 1.4571	315	4 570	56	0.12
222-14180-6	BUSHING VA RI G 1/2AxG 3/8	G 1/2A	G 3/8	36	14	27	Stainless steel 1.4571	315	4 570	94	0.21
222-14180-9	BUSHING VA RI G 3/4AxG 3/8	G 3/4A	G 3/8	26	16	32	Stainless steel 1.4571	315	4 570	87	0.19
222-13618-3	BUSHING VA RI G 3/4AxG 1/2	G 3/4A	G 1/2	41	16	32	Stainless steel 1.4571	315	4 570	143	0.32
222-14180-5	BUSHING VA RI G 1AxG 3/4	G 1A	G 3/4	47	18	41	Stainless steel 1.4571	315	4 570	278	0.61

## Adapter fittings

# Banjo fittings, rotatable

91308

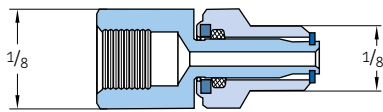

223-12567-1

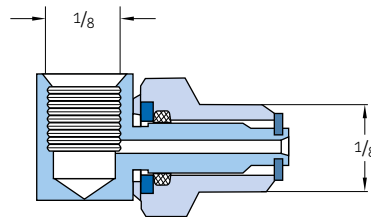

626-25702-1

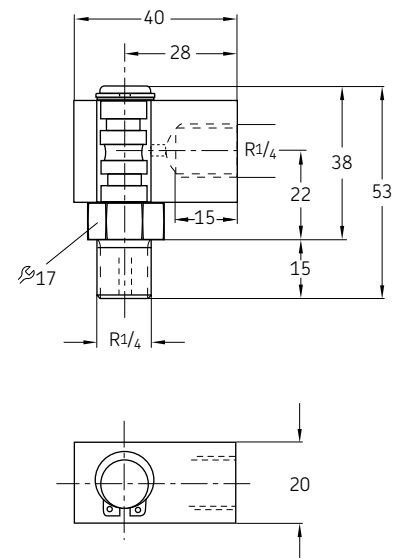

Order number	Designation	Tube Ø		Speed max.	Operation pressure max.		Material	Weight		
		Ø D <sub>1</sub>	Ø D <sub>2</sub>		min <sup>-1</sup>	bar		psi	g	lb
		mm	in							
091308	Straight swivel 1/8 NPT	–	1/8 NPT	1/8 NPT	1	50	725	Steel galvanized	20	0.04
223-12567-1	Swivel 90° 1/8 NPT	–	1/8 NPT	1/8 NPT	1	50	725	Steel galvanized	40	0.08
626-25702-1	Swivel R1/4XR1/4 MS	–	R1/4 male	R1/4 female	1	200	2 900	Brass	102	0.22

626-2...

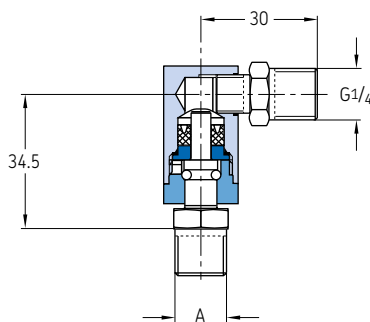

626-25720-2

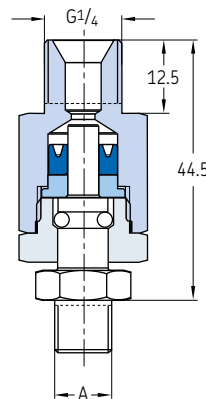

626-26696-2

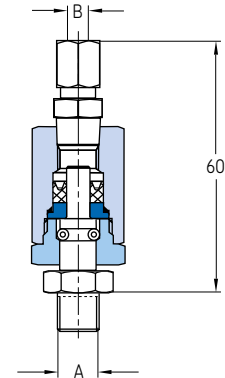

Order number	Designation	Tube Ø		Speed max.	Operation pressure max.		Material	Weight		
		Ø D <sub>1</sub>	Ø D <sub>2</sub>		min <sup>-1</sup>	bar		psi	g	lb
		mm	in							
626-25716-2	Swivel 90° G1/4AxG1/4A F	–	G1/4 male	G1/4 male	80	100	1 450	Steel galvanized	105	0.23
626-25540-2	Swivel 90° G1/4AxG1/8A F	–	G1/4 male	G1/8 male	80	100	1 450	Steel galvanized	105	0.23
626-26700-2	Swivel 90° G1/8AxD 4 F	4	–	G1/8 male	80	100	1 450	Steel galvanized	95	0.21
626-25438-2	Swivel 90° G1/8AxD 6 F	6	–	G1/8 male	80	100	1 450	Steel galvanized	100	0.22
626-26701-2	Swivel 90° G1/4AxD 4 F	4	–	G1/4 male	80	100	1 450	Steel galvanized	105	0.23
626-25717-2	Swivel 90° G1/4AxD 6 F	6	–	G1/4 male	80	100	1 450	Steel galvanized	102	0.22
626-26696-2	Swivel straight G1/8AXD 4 CF	4	–	G1/8	80	100	1 450	Steel galvanized	105	0.23

## Adapter fittings

## Banjo fittings, rotatable

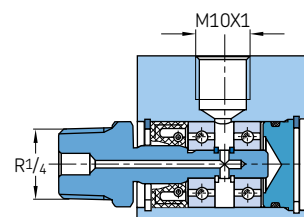

Order number	Designation	Tube ØD	Thread <sub>1</sub>	Thread <sub>2</sub>	Speed max.	Oil pressure max.		Air pressure max.		Material	Weight	
		mm	in	mm	min <sup>-1</sup>	bar	psi	bar	psi		g	lb
Brass												
<b>DLY930-2</b>	ROTATING JOINT MS 8 G1/4A	8	G 1/4 A	M14x1,5	1400	20	290	8	116	Brass	246	0.54
<b>DLY931</b>	ROTATING JOINT MS 8 R1/8K	8	R 1/8	M14x1,5	1400	20	290	8	116	Brass	244	0.54
Aluminum												
<b>DLY932</b>	ROTATING JOINT AL 8 R1/4K	6	R 1/4	M10x1	1400	5	72	–	–	Aluminum	65	0.14

## Plugs

### Vent plugs with profile seal acc. to ISO 9974-2

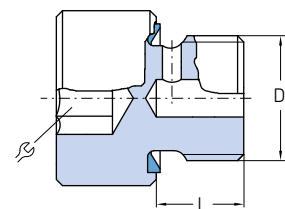

Order number	Designation	D <sub>1</sub>	L	ϕ	Material	Weight	
			mm			mm	g
466-431-006	VENTILATING SCREW,HEX. ST M10x1	M10x1	7	10	Steel, galvanized	10	0.02
466-431-005	VENTILATING SCREW,6-SOCK ST M10x1	M10x1	7	5	Steel, galvanized	10	0.02
466-431-009	VENTILATING SCREW,6-SOCK ST G 1/8A	G 1/8A	7	5	Steel, galvanized	11	0.02

### Vent plugs sealed by flat washer acc. to DIN 7603

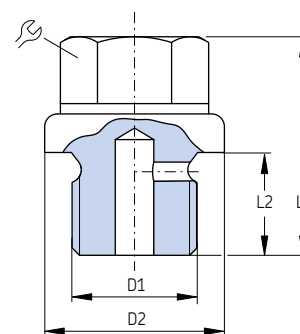

Order number	Designation	D <sub>1</sub>	D <sub>2</sub>	L <sub>1</sub>	L <sub>2</sub>	ϕ	Material	Operating pressure max.		Weight	
				mm	mm			mm	mm	bar	psi
833-020-022	VENTILATING SCREW ST M 8x1	M8x1	12	13,5	7,5	11	Steel, galvanized	45	650	7	0.015
833-330-016	VENTILATING SCREW ST M10x1	M10x1	14	17	8	11	Steel, galvanized	45	650	11	0.024
833-330-021	VENTILATING SCREW ST G 1/8A	G 1/8 A	14	17	8	11	Steel, galvanized	45	650	10	0.022
833-340-034	VENTILATING SCREW ST G 1/4A	G 1/4 A	18	17	8	11	Steel, galvanized	45	650	22	0.049

## Plugs

## Screw plugs VSTI

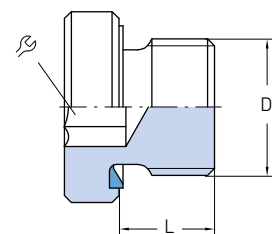

Order number	Designation	Tube ØD	D <sub>1</sub>	L	ϕ	Material	Operating pressure max.		Weight	
							bar	psi	g	lb
			mm	mm	mm					
Steel galvanized										
466-419-001	PLUG,CLOS.6-SOCK VSTI G 1/8A-ED CF	G 1/8A	14	8	5	Steel, galvanized	400	5 800	8	0.02
223-13702-1	PLUG 6-SOCK ST VSTI G 1/4A-ED CF	G 1/4A	19	12	6	Steel, galvanized	400	5 800	20	0.04
223-13702-7	PLUG 6-SOCK ST VSTI G 1/2A-ED CF	G 1/2A	27	14	10	Steel, galvanized	400	5 800	51	0.11
223-13702-6	PLUG 6-SOCK ST VSTI G 3/4A -ED CF	G 3/4A	32	16	12	Steel, galvanized	400	5 800	79	0.17
223-10530-4	PLUG 6-SOCK ST VSTI G1A -ED CF	G 1A	39,9	16	17	Steel, galvanized	400	5 800	130	0.29
466-429-001	PLUG,CLOS.6-SOCK VSTI M 8x1-ED CF	M8x1 mm	12	8	4	Steel, galvanized	400	5 800	7	0.02
466-431-001	PLUG,CLOS.6-SOCK VSTI M10x1-ED CF	M10x1 mm	14	8	5	Steel, galvanized	400	5 800	8	0.02
466-439-001	PLUG,CLOS.6-SOCK VSTI M18x1,5-ED CF	M18x1,5 mm	23,9	14	8	Steel, galvanized	400	5 800	32	0.07
Stainless steel										
223-13702-5	PLUG 6-SOCK VA VSTI G1/4A -ED	G 1/4A	19	12	6	Stainless steel 1.4571	400	5 800	20	0.04
223-13702-9	PLUG 6-SOCK VA VSTI G1/2A -ED	G 1/2A	27	14	10	Stainless steel 1.4571	400	5 800	51	0.11

## Screw plugs sealed by flat washer acc. to DIN 7603

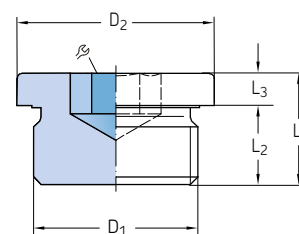

Order number	Designation	D <sub>1</sub>	D <sub>2</sub>	L <sub>1</sub>	L <sub>2</sub>	L <sub>3</sub>	ϕ	Material	Weight	
									g	lb
			mm	mm	mm	mm	mm			
DIN910-R1-8-5.8	PLUG,CLOSURE-HEX. 5.8 G 1/8AZN	G 1/8 A	14	17	8	3	11	Steel, galvanized	11	0.02
DIN910-R1-4x8-5.8	PLUG,CLOSURE-HEX. 5.8 G 1/4AZN	G 1/4 A	18	17	8	3	14	Steel, galvanized	19	0.04
DIN910-R3-8-5.8	PLUG,CLOSURE-HEX. 5.8 G 3/8AZN	G 3/8 A	22	21	12	3	17	Steel, galvanized	38	0.08
DIN910-R1-2-5.8	PLUG,CLOSURE-HEX. 5.8 G 1/2AZN	G 1/2 A	26	26	14	4	19	Steel, galvanized	68	0.15
DIN910-R3-4-5.8	PLUG,CLOSURE-HEX. 5.8 G 3/4AZN	G 3/4 A	32	30	16	4	24	Steel, galvanized	125	0.28
DIN910-R1-5.8	PLUG,CLOSURE-HEX. 5.8 G1 AZN	G 1 A	39	32	16	5	27	Steel, galvanized	199	0.44
402-011	PLUG,CLOSURE-HEX. ST M 6x0,75A SW10	M6x0.75	-	9	5	-	10	Steel, galvanized	4	0.01
404-011	PLUG,CLOSURE-HEX. ST M 8x1,0A SW11	M8x1	-	9,5	5,5	-	11	Steel, galvanized	5	0.01
406-011	PLUG,CLOSURE-HEX. ST M10x1,0A SW12	M10x1	-	12	7	-	12	Steel, galvanized	8	0.02
408-211	PLUG,CLOSURE-HEX. ST M12x1,0A SW17	M12x1	-	12	7	-	17	Steel, galvanized	14	0.03
408-011	PLUG,CLOSURE-HEX. ST M14x1,5A SW17	M14x1.5	-	12	7	-	17	Steel, galvanized	17	0.04
410-011	PLUG,CLOSURE-HEX. ST M16x1,5A SW19	M16x1.5	-	14	8	-	19	Steel, galvanized	25	0.06
412-011	PLUG,CLOSURE-HEX. ST M18x1,5A SW22	M18x1.5	-	15	10	-	22	Steel, galvanized	33	0.07
DIN908-M10x1-5.8	PLUG,CLOS6-SOCK 5.8 M10x1,5 ZN	M10x1	14	11	8	3	5 <sup>1)</sup>	Steel, galvanized	7	0.02
DIN908-M12x1.5-5.8	PLUG,CLOS6-SOCK 5.8 M12x1,0 ZN	M12x1.5	17	15	12	3	6 <sup>1)</sup>	Steel, galvanized	12	0.03
DIN908-M14x1.5-5.8	PLUG,CLOS6-SOCK 5.8 M14x1,5 ZN	M14x1.5	19	15	12	3	6 <sup>1)</sup>	Steel, galvanized	16	0.04
DIN908-G1-8A-5.8	PLUG,CLOS6-SOCK 5.8 G 1/8AZN	G 1/8 A	14	11	8	3	5 <sup>1)</sup>	Steel, galvanized	5	0.01
DIN908-G3-8A-5.8	PLUG,CLOS6-SOCK 5.8 G 3/8AZN	G 3/8 A	22	15	12	3	8 <sup>1)</sup>	Steel, galvanized	10	0.02



## Washers

### Flat washers

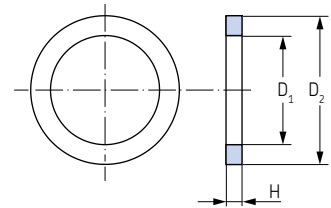

Order number	Designation		D <sub>1</sub>	D <sub>2</sub>	H	For thread		Material	Weight (100 pcs)	
			mm	mm		mm	mm		in	g
<b>Aluminum</b>										
<b>504-019-AL</b>	SEALING RING AL	10,2x13,9x1,1	10,2	13,9	1,1	M10	G 1/8	Aluminum	100	0.22
<b>Copper</b>										
<b>DIN7603-A6x10-CU</b>	SEALING RING CU	6,2x 9,9x1,0	6,2	9,9	1	M6	–	Copper	100	0.22
<b>DIN7603-A8x11.5-CU</b>	SEALING RING CU	8,2x 11,4x1,0	8,2	11,4	1	M8	–	Copper	100	0.22
<b>504-019</b>	SEALING RING CU	10,2x 13,9x1,1	10,2	13,9	1,1	M10	G 1/8	Copper	100	0.22
<b>508-215-CU</b>	SEALING RING CU	12,2x 15,9x1,4	12,2	15,9	1,4	M12	–	Copper	100	0.22
<b>508-320-CU</b>	SEALING RING CU	12,2x 15,9x 2,0	12,2	15,9	2	M12	–	Copper	100	0.22
<b>DIN7603-A12x18-CU</b>	SEALING RING CU	12,2x 14,9x 1,0	12,2	14,9	1	M12	–	Copper	100	0.22
<b>508-108</b>	SEALING RING CU	13,3x 17,9x 1,5	13,3	17,9	1,5	–	G 1/4	Copper	100	0.22
<b>DIN7603-A14x18-CU</b>	SEALING RING CU	14,2x 17,9x 1,5	14,2	17,9	1,5	M14	–	Copper	200	0.44
<b>DIN7603-A16x20-CU</b>	SEALING RING CU	16,2x 19,9x 1,5	16,2	19,9	1,5	M16	–	Copper	200	0.44
<b>DIN7603-A17x21-CU</b>	SEALING RING CU	17,2x 20,9x 1,5	17,2	20,9	1,5	–	G 3/8	Copper	200	0.44
<b>DIN7603-A18x22-CU</b>	SEALING RING CU	18,2x 21,9x 1,5	18,2	21,9	1,5	M18	–	Copper	200	0.44
<b>DIN7603-A20x24-CU</b>	SEALING RING CU	20,2x 23,9x 1,5	20,2	23,9	1,5	M20	–	Copper	200	0.44
<b>DIN7603-A21x26-CU</b>	SEALING RING CU	21,2x 25,9x 1,5	21,2	25,9	1,5	–	G 1/2	Copper	200	0.44
<b>DIN7603-A22x27-CU</b>	SEALING RING CU	22,2x 26,9x 1,5	22,2	26,9	1,5	M22	–	Copper	300	0.66
<b>DIN7603-A27x32-CU</b>	SEALING RING CU	27,3x 31,9x 2,0	27,3	31,9	2	M27	–	Copper	400	0.88
<b>DIN7603-A30x36-CU</b>	SEALING RING CU	30,3x 35,9x 2,0	30,3	35,9	2	M30	–	Copper	500	1.10
<b>DIN7603-A33x39-CU</b>	SEALING RING CU	33,3x 38,9x 2,0	33,3	38,9	2	M33	–	Copper	500	1.10

## Quick connectors



### Description

SKF quick connectors are the faster alternative when it comes to connecting pipes. Push-in type connectors are available for fast establishment of secure connections. Simply plug the end of the line into the pre-installed connector – all done! No wrench is required. Connections can be made more easily and quickly, especially in difficult-to-access areas. Push-in type fittings can be used to connect the entire system of lines from the pump to the metering devices, pressure switches, etc. – all the way to the lubrication points. The fittings feature internal claws to hold the tubing tight, even at 350 bar (5076 psi). They are equally suitable for plastic and steel tubing. Two versions of quick connectors are offered by SKF:

- Single-seal quick connectors (350 bar, 5076 psi) suitable for grease lubrication systems
- Triple-seal quick connectors (300 bar, 4350 psi) suitable for oil and grease lubrication systems

### Features and benefits

- Fast and virtually leakage-free connection
- No wrench tightening required
- Time savings due to easy and quick system assembly
- Connections in systems (without system pressure) can be easily opened and reclosed again
- Protection against penetrating dirt



## Applications

- Food and beverage industry
- Renewable energy industry
- Construction machinery
- Asphalt mixing plants
- Agricultural machines
- Material handling
- On-road vehicles
- Etc.

## Quick connectors

## Single-seal quick connectors (350 bar)

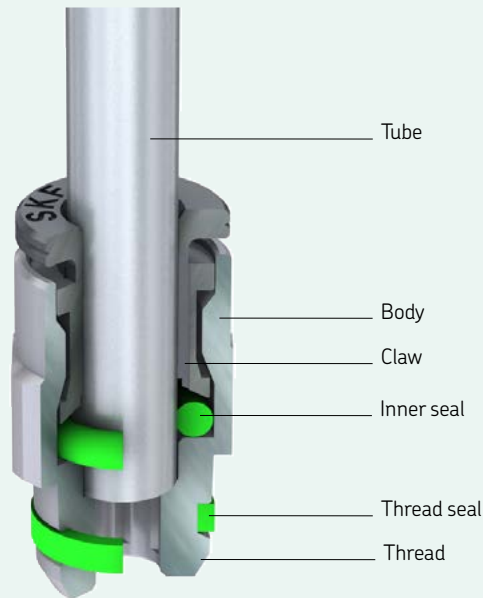

## Description

SKF single-seal quick connectors have one O-ring. They are suitable for grease lubrication systems with system pressures up to 350 bar.

## Features and benefits

- Suitable for grease
- Smaller
- Protection caps needed under harsh conditions
- Max. operating pressure 350 bar
- For tube  $\varnothing 6$  mm
- Marking of the collet: with groove
- Surface: nickel-plated C5M (sea water proof)
- Pipe sealing, expansion ring for collet chuck
- Plastic pipes can be used without claw groove
- Thread sealing via spring ring

## Single-seal quick connectors

### Straight screw-in connectors

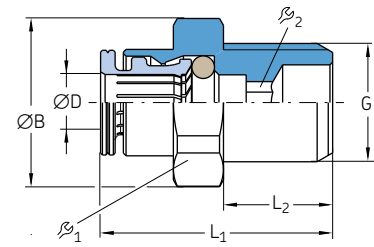

Order number	Designation	Tube ØD	G	ØB	L <sub>1</sub>	L <sub>2</sub>	β <sub>1</sub>	β <sub>2</sub>	Seal	Material	Operating pressure max.		Weight (100 pcs)	
											bar	psi	g	lb
226-14139-1	PUSH-IN FITT.GEZM 6-1/4	6	G 1/4B	18,5	12	25,5	17	4	NBR	Brass, nickel-plated	350	5 080	2 000	4.41

### Straight screw-in connectors with FKM threaded seal

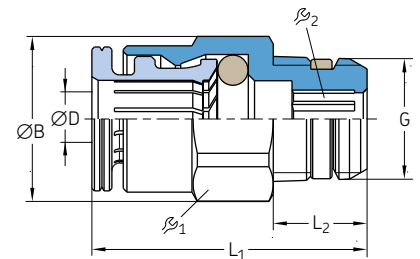

Order number	Designation	Tube ØD	G	ØB	L <sub>1</sub>	L <sub>2</sub>	β <sub>1</sub>	β <sub>2</sub>	Seal	Material	Operating pressure max.		Weight (100 pcs)	
											bar	psi	g	lb
226-14111-1	PUSH-IN FITT.GEKM S 6-1/8	6	R 1/8	13,2	7.5	22	12	4	FKM	Brass, nickel-plated	350	5 080	1 000	2.21
226-10205-5	PUSH-IN FITT.GEZM S 6-1/4	6	G 1/4B	15,2	7	21,5	14	4	FKM	Brass, nickel-plated	350	5 080	1 400	3.09

## Single-seal quick connectors

## Adapters with tapered thread

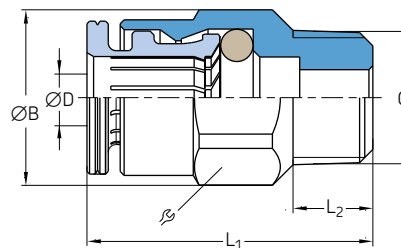

Order number	Designation	Tube ØD G	ØB	L <sub>1</sub>	L <sub>2</sub>	R	Seal	Material	Operating pressure max.		Weight (100 pcs)	
									bar	psi	g	lb
226-14111-4	PUSH-IN FITT. GEKM 6-M6×1	6 M6×1 tap.	13,2	24	6	12	NBR	Brass, nickel-plated	350	5 080	900	1,98
226-14111-2	PUSH-IN FITT. GEKM 6-M8×1	6 M8×1 tap.	13,2	23	6	12	NBR	Brass, nickel-plated	350	5 080	1 000	2,21
226-14111-3	PUSH-IN FITT. GEKM 6-M10×1	6 M10×1 tap.	13,2	21,5	6	12	NBR	Brass, nickel-plated	350	5 080	1 000	2,21
226-10622-8	PUSH-IN FITT. GEKM 6-1/8	6 R 1/8	13,2	22	7,5	12	NBR	Brass, nickel-plated	350	5 080	1 000	2,21

## Banjo fittings with tapered thread

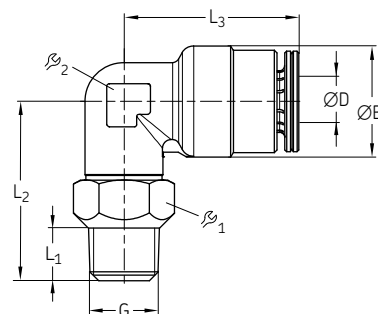

Order number	Designation	Tube ØD G	ØB	L <sub>1</sub>	L <sub>2</sub>	L <sub>3</sub>	R <sub>1</sub>	R <sub>2</sub>	Seal	Material	Operating pressure max.		Weight (100 pcs)	
											bar	psi	g	lb
226-14157-3	PUSH-IN FITT. WEDKM 6-M 6×1	6 M6×1 tap.	12,7	6	20,5	20	10	9	NBR	Brass, nickel-plated	350	5 080	1 600	3,53
226-14157-1	PUSH-IN FITT. WEDKM 6-M 8×1	6 M8×1 tap.	12,7	6	20,5	20	10	9	NBR	Brass, nickel-plated	350	5 080	1 600	3,53
226-14157-2	PUSH-IN FITT. WEDKM 6-M10×1	6 M10×1 tap.	12,7	6	20,5	20	12	9	NBR	Brass, nickel-plated	350	5 080	2 000	4,41
226-13756-9	PUSH-IN FITT. WEDKM 6-1/8	6 R 1/8	12,7	7,5	21	20	12	9	NBR	Brass, nickel-plated	350	5 080	1 900	4,19

## Single-seal quick connectors

### Elbows with tapered thread

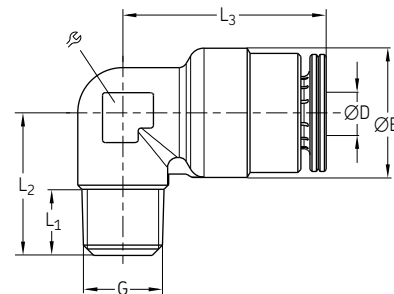

Order number	Designation	Tube ØD	G	ØB	L <sub>1</sub>	L <sub>2</sub>	L <sub>3</sub>	⌀	Seal	Material	Operating pressure max.		Weight (100 pcs) max.	
											bar	psi	g	lb
226-14123-4	PUSH-IN FITT. WEKM 6-M 6×1	6	M6×1 tap.	12,7	6	15	20	9	NBR	Brass, nickel-plated	350	5 080	1 400	3.09
226-14123-2	PUSH-IN FITT. WEKM 6-M 8×1	6	M8×1 tap.	12,7	6,5	14	20	9	NBR	Brass, nickel-plated	350	5 080	1 300	2.87
226-14123-3	PUSH-IN FITT. WEKM 6-M10×1	6	M10×1 tap.	12,7	6	14	20	9	NBR	Brass, nickel-plated	350	5 080	1 500	3.31
226-14123-5	PUSH-IN FITT. WEKM 6-1/8	6	R 1/8	12,7	7,5	15,5	20	9	NBR	Brass, nickel-plated	350	5 080	1 400	3.09
226-13753-9	1) PUSH-IN FITT. WEKM S 6-1/8	6	R 1/8	12,7	7,5	15,5	20	9	NBR	Brass, nickel-plated	350	5 080	1 400	3.09

1) with FKM threaded seal

### Banjo fittings with O-ring threaded seal

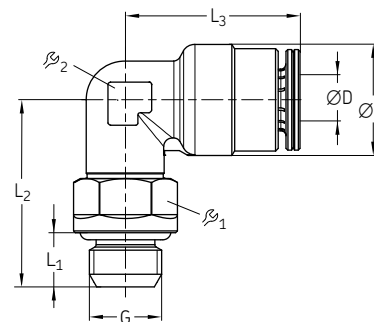

Order number	Designation	Tube ØD	G	ØB	L <sub>1</sub>	L <sub>2</sub>	L <sub>3</sub>	⌀ <sub>1</sub>	⌀ <sub>2</sub>	Seal	Material	Operating pressure max.		Weight (100 pcs) max.	
												bar	psi	g	lb
226-11313-8	PUSH-IN FITT. WEDZM 6-1/4B	6	G 1/4B	12,7	7	23	20	15	9	NBR	Brass, nickel-plated	350	5 080	2 500	5.51
226-11313-9	PUSH-IN FITT. WEDZM 6-1/8B	6	G 1/8B	12,7	6	21	20	12	9	NBR	Brass, nickel-plated	350	5 080	2 300	5.07
226-11315-1	PUSH-IN FITT. WEDZM 6-M 6	6	M6×1	12,7	7	21	20	10	9	NBR	Brass, nickel-plated	350	5 080	2 300	5.07
226-11315-2	PUSH-IN FITT. WEDZM 6-M 8×1	6	M8×1	12,7	7	22	20	10	9	NBR	Brass, nickel-plated	350	5 080	2 400	5.29

## Single-seal quick connectors

### Banjo fittings with FKM threaded seal

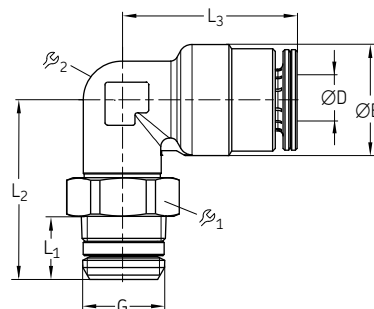

Order number	Designation	Tube		ØB	L <sub>1</sub>	L <sub>2</sub>	L <sub>3</sub>	ϕ <sub>1</sub>	ϕ <sub>2</sub>	Seal	Material	Operating pressure max.		Weight (100 pcs)	
		ØD	G									mm	in	mm	mm
226-14157-4	PUSH-IN FITT. WEDKM S 6-1/4	6	R1/4	12,7	11	24,5	20,1	14	9	NBR	Brass, nickel-plated	350	5 080	2 000	4.41
226-14157-5	PUSH-IN FITT. WEDKM S 6-1/8	6	R1/8	12,7	7,5	21	20	12	9	NBR	Brass, nickel-plated	350	5 080	1 900	4.19

### Banjo fittings with hexagon socket and O-ring threaded seal

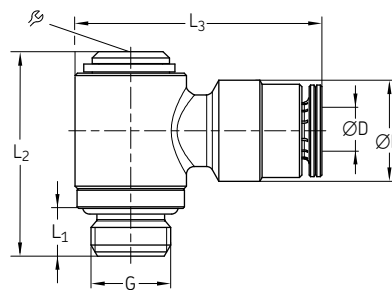

Order number	Designation	Tube		ØB	L <sub>1</sub>	L <sub>2</sub>	L <sub>3</sub>	ϕ	Seal	Material	Operating pressure max.		Weight (100 pcs)	
		ØD	G								mm	mm	mm	mm
226-10223-2	PUSH-IN FITT. WEDZM 6-1/8	6	G1/8B	12,7	6	25,7	24,1	5	NBR	Brass, nickel-plated	350	5 080	2 700	5.95
226-10223-4	PUSH-IN FITT. WEDZM 6-M 8x1	6	M 8x1	12,7	6	26	24	5	NBR	Brass, nickel-plated	350	5 080	2 500	5.51
226-10223-6	PUSH-IN FITT. WEDZM 6-M10x1	6	M10x1	12,7	6	25,7	24,1	5	NBR	Brass, nickel-plated	350	5 080	2 600	5.73



## Single-seal quick connectors

# Screw-in T-connectors

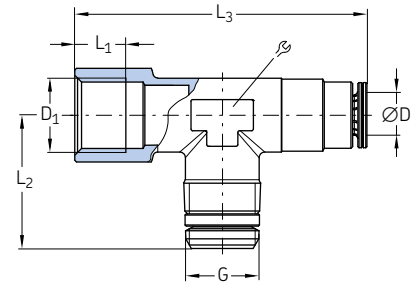

Order number	Designation	Tube		D <sub>1</sub>	L <sub>1</sub>	L <sub>2</sub>	L <sub>3</sub>	ϕ	Seal	Material	Operating pressure max.		Weight	
		ØD	G								bar	psi	g	lb
		mm		mm	mm	mm	mm	mm						
226-14097-5	PUSH-IN FITT. TSM S 6-1/4	6	G 1/4	G 1/4	9	23,5	51,5	14	NBR	Brass, nickel-plated	350	5 080	50	0.11

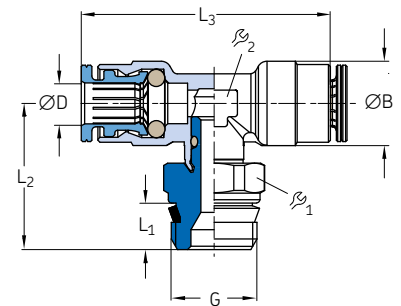

Order number	Designation	Tube		ØB	L <sub>1</sub>	L <sub>2</sub>	L <sub>3</sub>	ϕ <sub>1</sub>	ϕ <sub>2</sub>	Seal	Material	Operating pressure max.		Weight	
		ØD	G									bar	psi	g	lb
		mm		mm	mm	mm	mm	mm	mm						
226-10159-1	PUSH-IN FITT. TEDZM S 6-1/8	6	G 1/8B	12,7	5,5	20,3	40,2	9	9	NBR	Brass, nickel-plated	350	5 080	27	0.06
226-10159-9	PUSH-IN FITT. TEDZM S 6-1/4	6	G 1/4B	12,7	7	22	40	14	9	NBR	Brass, nickel-plated	350	5 080	35	0.08

## Single-seal quick connectors

### T-connectors

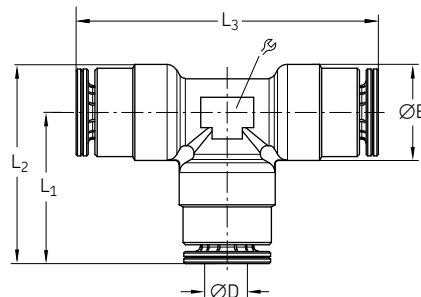

Order number	Designation	Tube ØD	ØB	L <sub>1</sub>	L <sub>2</sub>	L <sub>3</sub>	⌀	Seal	Material	Operating pressure max.		Weight	
										bar	psi	g	lb
226-14097-4	PUSH-IN FITT. TSM 6	6	12,7	20	26	40	6	NBR	Brass, nickel-plated	350	5 080	20	0.04

### Straight bulkhead connectors

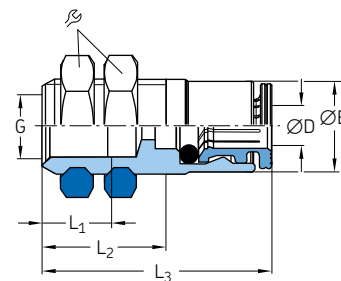

Order number	Designation	Tube ØD	G	ØB	L <sub>1</sub>	L <sub>2</sub>	L <sub>3</sub>	⌀	Seal	Material	Operating pressure max.		Weight	
											bar	psi	g	lb
226-10214-4	PUSH-IN FITT. SVM 6-G 1/8	6	G 1/8	12,5	9	17	31,6	17	NBR	Brass, nickel-plated	350	5 080	26	0.06
226-10214-7	PUSH-IN FITT. SVM 6-M 8x1	6	M 8x1	12,5	9	17	31,5	17	NBR	Brass, nickel-plated	350	5 080	27	0.06

## Single-seal quick connectors

### Tube-to-tube connector

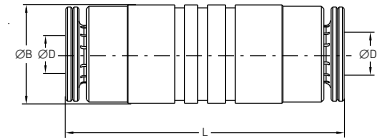

Order number	Designation	Tube	ØB	L	Seal	Material	Operating pressure max.		Weight	
		ØD	mm	mm			bar	psi	g	lb
226-13773-4	CONNECTOR GSM 6	6	12	34	NBR	Brass, nickel-plated	350	5 080	18	0.04

## Triple-seal quick connectors

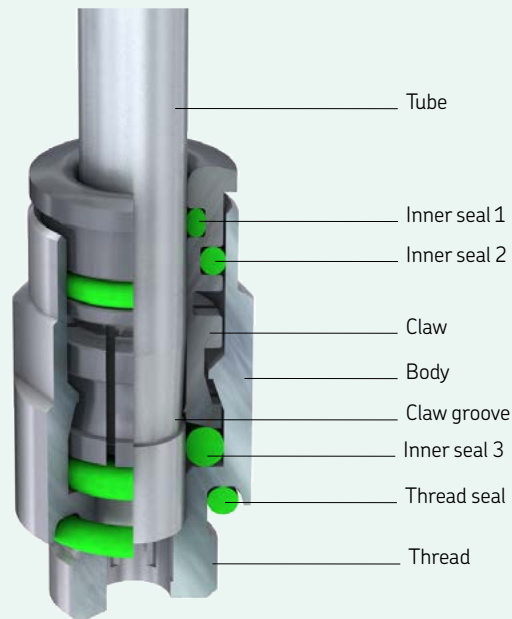

### Claw grooves

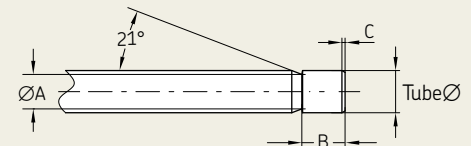

### Description

SKF triple-seal quick connectors have three O-rings. They are suitable for oil lubrication systems with system pressures up to 300 bar. For a good union, steel pipes or fittings used as hose end fittings must be prepared with a claw groove. Plastic pipes can be connected directly without an additional claw groove.

### For metal pipes, a claw groove is required at the end of the pipe

Tube Ø	A +0,3	B ±0,2	C
4	3,1	5	0,3 ... 0,7
6	4,9	6,2	0,4 ... 0,9
8	6,9	6,2	0,5 ... 0,9

Tool for the production of pipe ends (cutting and groove-forming) available in the chapter on tools.

### Features and benefits

- Suitable for oil and fluid grease
- Better sealing by three O-rings (leakage-free)
- Max. operating pressure 300 bar
- For tube Ø4, 6 and 8 mm
- Marking of the collet: plain
- Surface: collet nickel-plated C4
- Insertion depth for plastic and steel tubing
  - Ø4 mm: 19 mm
  - Ø6 mm: 22 mm
  - Ø8 mm: 24 mm
- Reduction of bending forces
- Sealing for the pipe, expansion ring for collet chuck
- Sealing thread O-ring

## Triple-seal quick connectors

# Straight screw-in connectors with cylindrical thread

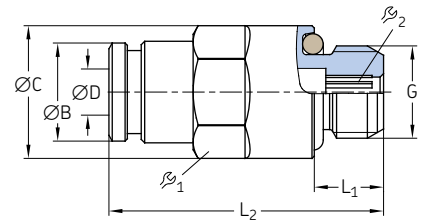

Order number	Designation	Tube G ØD	ØB	ØC	L <sub>1</sub>	L <sub>2</sub>	r <sub>1</sub>	r <sub>2</sub>	Seal	Material	Operating pressure max.	Weight (100 pcs)
		mm	mm	mm	mm	mm	mm	mm			bar psi	g lb
451-004-260-VS	PUSH-IN FITT.GEZ 4-M6 NBR	4	M6	8,8	11,5	4,5	25	10	2,5	NBR	Brass	300 4 350 1 000 2.21
404-073-VS	PUSH-IN FITT.GEZ 4-M6x0,75 NBR	4	M6x0,75	8,8	11,5	4,5	25,3	10	2,5	NBR	Brass	300 4 350 1 000 2.21
404-063-VS	PUSH-IN FITT.GEZ 4-M8 NBR	4	M8	8,8	11,5	6	23,8	10	2,5	NBR	Brass	300 4 350 900 1.98
404-003-VS	PUSH-IN FITT.GEZ 4-M8x1 NBR	4	M8x1	8,8	11,5	6	23,8	10	2,5	NBR	Brass	300 4 350 900 1.98
404-003-S8-VS	PUSH-IN FITT.GEZ 4-M8x1 FPM	4	M8x1	8,8	11,5	6	23,8	10	2,5	FPM	Brass	300 4 350 1 000 2.21
404-006-VS	PUSH-IN FITT.GEZ 4-M10x1 NBR	4	M10x1	8,8	13,5	6	23,8	12	2,5	NBR	Brass	300 4 350 1 400 3.09
404-006-S8-VS	PUSH-IN FITT.GEZ 4-M10x1 FPM	4	M10x1	8,8	13,5	6	23,8	12	2,5	FPM	Brass	300 4 350 1 400 3.09
404-040-VS	PUSH-IN FITT.GEZ 4-G1/8 NBR	4	G 1/8	8,8	13,5	6	23,8	12	2,5	NBR	Brass	300 4 350 1 400 3.09
406-158-VS	PUSH-IN FITT. GEZ 6-M8x1 NBR	6	M8x1	11,7	13,2	6	30,5	12	3	NBR	Brass	300 4 350 1 500 3.31
406-004-VS	PUSH-IN FITT. GEZ 6-M10x1 NBR	6	M10x1	11,7	13,5	6	27	12	4	NBR	Brass	300 4 350 1 500 3.31
406-004-S8-VS	PUSH-IN FITT. GEZ 6-M10x1 FPM	6	M10x1	11,7	13,5	6	27	12	4	FPM	Brass	300 4 350 1 400 3.09
456-004-VS	PUSH-IN FITT. GEZ 6-G1/8 NBR	6	G 1/8	11,7	13,5	6	27	12	4	NBR	Brass	300 4 350 1 400 3.09
456-004-S8-VS	PUSH-IN FITT. GEZ 6-G1/8 FPM	6	G 1/8	11,7	13,5	6	27	12	4	FPM	Brass	300 4 350 1 400 3.09
406-054-VS	PUSH-IN FITT. GEZ 6-G1/4 NBR	6	G 1/4	11,7	16,4	7	28	12	4	NBR	Brass	300 4 350 1 900 4.19
406-162-VS	PUSH-IN FITT. GEZ 6-M12x1 NBR	6	M12x1	11,7	15,4	7	28	14	4	NBR	Brass	300 4 350 2 200 4.85
406-162-S8-VS	PUSH-IN FITT. GEZ 6-M12x1 FPM	6	M12x1	11,7	15,4	7	28	14	4	FPM	Brass	300 4 350 2 400 5.29
408-004-VS	PUSH-IN FITT. GEZ 8-M10x1 NBR	8	M10x1	13,9	15,2	6	32,3	14	5	NBR	Brass	300 4 350 2 000 4.41
408-004-S8-VS	PUSH-IN FITT. GEZ 8-M10x1 FPM	8	M10x1	13,9	15,2	6	32,3	14	5	FPM	Brass	300 4 350 2 000 4.41
408-162-VS	PUSH-IN FITT. GEZ 8-M12x1 NBR	8	M12x1	13,9	15,2	7	32,8	14	6	NBR	Brass	300 4 350 2 300 5.07
408-162-S8-VS	PUSH-IN FITT. GEZ 8-M12x1 FPM	8	M12x1	13,9	15,2	7	32,8	14	6	FPM	Brass	300 4 350 2 000 4.41
408-054-VS	PUSH-IN FITT. GEZ 8-G1/4 NBR	8	G 1/4	13,9	16,4	7	30,8	15	6	NBR	Brass	300 4 350 3 000 6.62

# Straight screw-in connectors with tapered thread

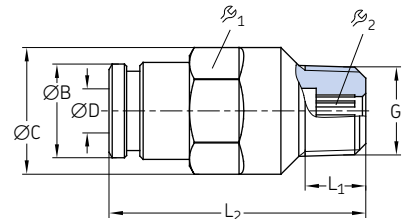

Order number	Designation	Tube G ØD	ØB	ØC	L <sub>1</sub>	L <sub>2</sub>	r <sub>1</sub>	r <sub>2</sub>	Seal	Material	Operating pressure max.	Weight (100 pcs)
		mm	mm	mm	mm	mm	mm	mm			bar psi	g lb
451-004-462-VS	PUSH-IN FITT. GEK 4-M6K NBR	4	M6 tap.	8,8	11,5	5,5	25,8	10	2,5	NBR	Brass	300 4 350 900 1.98
451-004-471-VS	PUSH-IN FITT. GEK 4-M6x0,75K NBR	4	M6x0,75 tap.	8,8	11,5	5,5	25,8	10	2,5	NBR	Brass	300 4 350 900 1.98
451-004-498-VS	PUSH-IN FITT. GEK 4-M8x1K NBR	4	M8x1 tap.	8,8	11,5	5,5	23,3	10	2,5	NBR	Brass	300 4 350 900 1.98
451-004-518-VS	PUSH-IN FITT. GEK 4-M10x1K NBR	4	M10x1 tap.	8,8	11,5	5,5	22,8	10	2,5	NBR	Brass	300 4 350 1 100 2.43
404-673K-V1-VS	PUSH-IN FITT. GEK 4-1/4-28 SAE LT NBR	4	1/4-28 SAE LT	8,8	11,5	5,1	26,3	10	2,5	NBR	Brass	300 4 350 1 000 2.21
404-040K-V1-VS	PUSH-IN FITT. GEK 4-1/8 NPTF NBR	4	1/8 NPTF	8,8	11,5	8	24,8	10	2,5	NBR	Brass	300 4 350 1 200 2.65
451-006-468-VS	PUSH-IN FITT. GEK 6-M6K NBR	6	M6 tap.	11,7	13,5	5,5	30	12	2,5	NBR	Brass	300 4 350 1 400 3.09
451-006-498-VS	PUSH-IN FITT. GEK 6-M8x1K NBR	6	M8x1 tap.	11,7	13,5	5,5	29,5	12	4	NBR	Brass	300 4 350 1 400 3.09
451-006-518-VS	PUSH-IN FITT. GEK 6-M10x1K NBR	6	M10x1 tap.	11,7	13,5	5,5	27	12	4	NBR	Brass	300 4 350 1 500 3.31
406-423W-VS	PUSH-IN FITT. GEK 6-R1/8K NBR	6	R 1/8	11,7	13,5	6,5	28,5	12	4	NBR	Brass	300 4 350 1 500 3.31
406-423N-VS	PUSH-IN FITT. GEK 6-1/8 NPT NBR	6	1/8 NPT	11,7	13,5	7,5	28,5	12	4	NBR	Brass	300 4 350 1 600 3.53

## Triple-seal quick connectors

## Tube-to-tube connectors

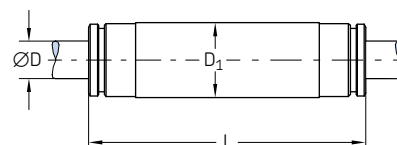

Order number	Designation	Tube ØD	D <sub>1</sub>	L	Material	Operating pressure max.		Weight (100 pcs)	
						bar	psi	g	lb
454-504-041-VS	CONNECTOR GS 4 NBR	4	10	38,5	Brass	300	4 350	1 500	3.31
406-426-VS	CONNECTOR GS 6 NBR	6	12	44,5	Brass	300	4 350	2 000	4.41

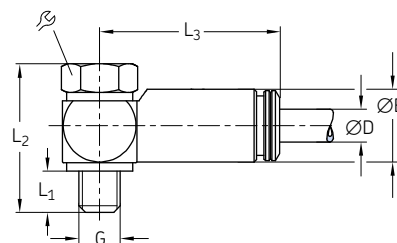
Banjo fittings with banjo bolt  
and cylindrical thread

Order number	Designation	Tube ØD	G	ØB	L <sub>1</sub>	L <sub>2</sub>	L <sub>3</sub>	Seal	Material	Operating pressure max.		Weight (100 pcs)		
										bar	psi	g	lb	
504-161-VS	BANJO FITTING SWVZ-4-M6 NBR	4	M6	8,8	5	19,5	22,3	9	NBR	Brass	300	4 350	1300	2.87
504-401-S1-VS	BANJO FITTING SWVZ-4-M5 NBR	4	M5	8,8	5	18	21,8	8	NBR	Brass	300	4 350	1100	2.43
504-411-VS	BANJO FITTING SWVZ-4-M8 NBR	4	M8	8,8	7	20	23,8	12	NBR	Brass	300	4 350	1700	3.75
504-401-VS	BANJO FITTING SWVZ-4-M8x1 NBR	4	M8x1	8,8	7	20	23,8	12	NBR	Brass	300	4 350	1800	3.97
504-103-VS	BANJO FITTING SWVZ-4-M10x1 NBR	4	M10x1	8,8	7	22,5	24,8	14	NBR	Brass	300	4 350	2 400	5.29
445-519-041-VS	BANJO FITTING SWVZ-4-G1/8A NBR	4	G 1/8A	8,8	7	22,5	24,8	14	NBR	Brass	300	4 350	2 400	5.29

## Triple-seal quick connectors

### Elbows with tapered thread

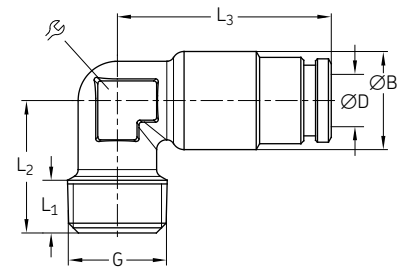

Order number	Designation	Tube ØD	G	D <sub>1</sub>	L <sub>1</sub>	L <sub>2</sub>	L <sub>3</sub>	⌀	Seal	Material	Operating pressure max.	Weight (100 pcs) max.	
		mm		mm	mm	mm	mm	mm			bar psi	g lb	
453-004-471-VS	PUSH-IN FITT. WEK 4-M6K NBR	4	M6 tap.	10	6	14	21,89		NBR	Brass	300 4 350	1 100	2.43
453-004-471-S8-VS	PUSH-IN FITT. WEK 4-M6K FPM	4	M6 tap.	10	6	14	21,89		FPM	Brass	300 4 350	1 200	2.65
504-201-VS	PUSH-IN FITT. WEK 4-M8x1K NBR	4	M8x1 tap.	10	6	13,5	21,89		NBR	Brass	300 4 350	1 100	2.43
504-201-S8-VS	PUSH-IN FITT. WEK 4-M8x1K FPM	4	M8x1 tap.	10	6	13,5	21,89		FPM	Brass	300 4 350	1 200	2.65
504-202-VS	PUSH-IN FITT. WEK 4-M10x1K NBR	4	M10x1 tap.	10	6	13,5	21,89		NBR	Brass	300 4 350	1 100	2.43
504-202-S8-VS	PUSH-IN FITT. WEK 4-M10x1K FPM	4	M10x1 tap.	10	6	13,5	21,89		FPM	Brass	300 4 350	1 300	2.87
514-018-VS	PUSH-IN FITT. WEK 4-R1/8K NBR	4	R 1/8	10	7,5	15	21,89		NBR	Brass	300 4 350	1 200	2.65
514-018-S8-VS	PUSH-IN FITT. WEK 4-R1/8K FPM	4	R 1/8	10	7,5	15	21,89		FPM	Brass	300 4 350	1 300	2.87
504-200K-V1-VS	PUSH-IN FITT. WEK 4-1/4-28SAE LT NBR	4	1/4-28SAE LT	10	5,1	15,5	21,89		NBR	Brass	300 4 350	1 200	2.65
514-018K-V1-VS	PUSH-IN FITT. WEK 4-1/8NPT NBR	4	1/8 NPT	10	7	15	21,89		NBR	Brass	300 4 350	1 300	2.87
453-006-468-VS	PUSH-IN FITT. WEK 6-M6K NBR	6	M6 tap.	12,5	6	15	26	10	NBR	Brass	300 4 350	2 000	4.41
453-006-468-S8-VS	PUSH-IN FITT. WEK 6-M6K FPM	6	M6 tap.	12,5	6	15	26	10	FPM	Brass	300 4 350	1 800	3.97
506-508-VS	PUSH-IN FITT. WEK 6-M8x1K NBR	6	M8x1 tap.	12,5	6,5	14	26	10	NBR	Brass	300 4 350	1 600	3.53
506-508-S8-VS	PUSH-IN FITT. WEK 6-M8x1K FPM	6	M8x1 tap.	12,5	6,5	14	26	10	FPM	Brass	300 4 350	1 800	3.97
506-510-VS	PUSH-IN FITT. WEK 6-M10x1K NBR	6	M10x1 tap.	12,5	6	14	26	10	NBR	Brass	300 4 350	1 600	3.53
506-510-S8-VS	PUSH-IN FITT. WEK 6-M10x1K FPM	6	M10x1 tap.	12,5	6	14	26	10	FPM	Brass	300 4 350	1 700	3.75
506-511-VS	PUSH-IN FITT. WEK 6-R1/8K NBR	6	R 1/8	12,5	8,5	16,5	26	10	NBR	Brass	300 4 350	1 700	3.75
506-511-S8-VS	PUSH-IN FITT. WEK 6-R1/8K FPM	6	R 1/8	12,5	8,5	16,5	26	10	FPM	Brass	300 4 350	1 800	3.97
506-511K-V1-VS	PUSH-IN FITT. WEK 6-1/8NPT NBR	6	1/8 NPT	12,5	8,5	16,5	26	10	NBR	Brass	300 4 350	1 900	4.19
455-565-068-VS	PUSH-IN FITT. WEK 6-R1/4K NBR	6	R 1/4	12,5	11,5	19,5	26	10	NBR	Brass	300 4 350	1 900	4.19

## Triple-seal quick connectors

## Banjo fittings with cylindrical thread

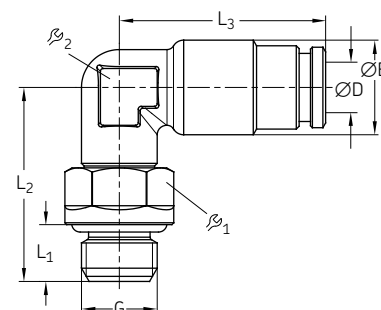

Order number	Designation	Tube G ØD	ØB	L <sub>1</sub>	L <sub>2</sub>	L <sub>3</sub>	β <sub>1</sub>	β <sub>2</sub>	Seal	Material	Operating pressure max.		Weight (100 pcs)		
											bar	psi	g	lb	
504-100-VS	PUSH-IN FITT. WEDZ 4-M6x1 NBR	4	M6x1	10	4,5	17,5	21,8	9	9	NBR	Brass	300	4 350	1 200	2.65
504-101-VS	PUSH-IN FITT. WEDZ 4-M8x1 NBR	4	M8x1	10	6	20,5	21,8	10	9	NBR	Brass	300	4 350	1 500	3.31
504-101-S8-VS	PUSH-IN FITT. WEDZ 4-M8x1 FPM	4	M8x1	10	6	20,5	21,8	10	9	FPM	Brass	300	4 350	1 500	3.31
504-102-VS	PUSH-IN FITT. WEDZ 4-M10x1 NBR	4	M10x1	10	6	20,5	21,8	12	9	NBR	Brass	300	4 350	2 000	4.41
504-102-S8-VS	PUSH-IN FITT. WEDZ 4-M10x1 FPM	4	M10x1	10	6	20,5	21,8	12	9	FPM	Brass	300	4 350	2 000	4.41
504-108-VS	PUSH-IN FITT. WEDZ 4-G1/8A NBR	4	G 1/8A	10	6	20,5	21,8	12	9	NBR	Brass	300	4 350	1 800	3.97
504-108-S8-VS	PUSH-IN FITT. WEDZ 4-G1/8A FPM	4	G 1/8A	10	6	20,5	21,8	12	9	FPM	Brass	300	4 350	1 900	4.19
506-139-VS	PUSH-IN FITT. WEDZ 6-M8x1 NBR	6	M8x1	12,5	6	21	26	10	10	NBR	Brass	300	4 350	1 900	4.19
506-139-S8-VS	PUSH-IN FITT. WEDZ 6-M8x1 FPM	6	M8x1	12,5	6	21	26	10	10	FPM	Brass	300	4 350	2 000	4.41
506-140-VS	PUSH-IN FITT. WEDZ 6-M10x1 NBR	6	M10x1	12,5	6	21	26	12	10	NBR	Brass	300	4 350	2 200	4.85
506-140-S8-VS	PUSH-IN FITT. WEDZ 6-M10x1 FPM	6	M10x1	12,5	6	21	26	12	10	FPM	Brass	300	4 350	2 200	4.85
506-108-VS	PUSH-IN FITT. WEDZ 6-G1/8A NBR	6	G 1/8A	12,5	6	21	26	12	10	NBR	Brass	300	4 350	2 200	4.85
506-108-S8-VS	PUSH-IN FITT. WEDZ 6-G1/8A FPM	6	G 1/8A	12,5	6	21	26	12	10	FPM	Brass	300	4 350	2 300	5.07
506-142-VS	PUSH-IN FITT. WEDZ 6-M12x1 NBR	6	M12x1	12,5	7	23	26	14	10	NBR	Brass	300	4 350	2 700	5.95
506-142-S8-VS	PUSH-IN FITT. WEDZ 6-M12x1 FPM	6	M12x1	12,5	7	23	26	14	10	FPM	Brass	300	4 350	2 700	5.95
506-143-VS	PUSH-IN FITT. WEDZ 6-G1/4A NBR	6	G 1/4A	12,5	7	23	26	15	10	NBR	Brass	300	4 350	2 900	6.39
508-142-VS	PUSH-IN FITT. WEDZ 8-M12x1 NBR	8	M12x1	14,5	7	23	28,8	14	12	NBR	Brass	300	4 350	3 200	7.06
508-142-S8-VS	PUSH-IN FITT. WEDZ 8-M12x1 FPM	8	M12x1	14,5	7	23	28,8	14	12	FPM	Brass	300	4 350	3 200	7.06



## Triple-seal quick connectors

# Banjo fittings with tapered thread

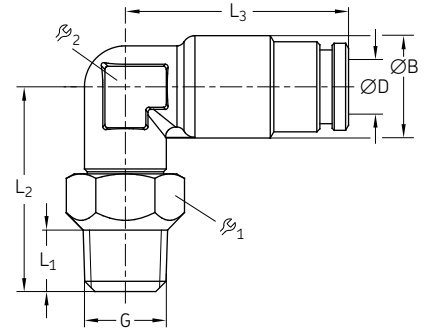

Order number	Designation	Tube ØD	G	ØB	L <sub>1</sub>	L <sub>2</sub>	L <sub>3</sub>	ϕ <sub>1</sub>	ϕ <sub>2</sub>	Seal	Material	Operating pressure max.		Weight (100 pcs)	
												bar	psi	g	lb
455-546-048-VS	PUSH-IN FITT. WEDK 4-M6K NBR	4	M6 tap.	10	6	20	21,8	10	9	NBR	Brass	300	4 350	1 400	3.09
455-546-048-S8-VS	PUSH-IN FITT. WEDK 4-M6K FPM	4	M6 tap.	10	6	20	21,8	10	9	FPM	Brass	300	4 350	1 500	3.31
455-529-048-VS	PUSH-IN FITT. WEDK 4-M8x1K NBR	4	M8x1 tap.	10	6	20	21,8	10	9	NBR	Brass	300	4 350	1 600	3.53
455-529-048-S8-VS	PUSH-IN FITT. WEDK 4-M8x1K FPM	4	M8x1 tap.	10	6	20	21,8	10	9	FPM	Brass	300	4 350	1 600	3.53
455-531-048-VS	PUSH-IN FITT. WEDK 4-M10x1K NBR	4	M10x1 tap.	10	6	20	21,8	12	9	NBR	Brass	300	4 350	1 800	3.97
455-531-048-S8-VS	PUSH-IN FITT. WEDK 4-M10x1K FPM	4	M10x1 tap.	10	6	20	21,8	12	9	FPM	Brass	300	4 350	1 800	3.97
455-569-048-VS	PUSH-IN FITT. WEDK 4-R1/8K NBR	4	R 1/8	10	7,5	20,5	21,8	12	9	NBR	Brass	300	4 350	2 000	4.41
455-529-068-VS	PUSH-IN FITT. WEDK 6-M8x1K NBR	6	M8x1 tap.	12,5	6	20,5	26	10	10	NBR	Brass	300	4 350	2 000	4.41
455-529-068-S8-VS	PUSH-IN FITT. WEDK 6-M8x1K FPM	6	M8x1 tap.	12,5	6	20,5	26	10	10	FPM	Brass	300	4 350	2 000	4.41
455-531-068-VS	PUSH-IN FITT. WEDK 6-M10x1K NBR	6	M10x1 tap.	12,5	6	20,5	26	12	10	NBR	Brass	300	4 350	2 300	5.07
455-531-068-S8-VS	PUSH-IN FITT. WEDK 6-M10x1K FPM	6	M10x1 tap.	12,5	6	20,5	26	12	10	FPM	Brass	300	4 350	2 300	5.07
455-546-068-VS	PUSH-IN FITT. WEDK 6-M6x1K NBR	6	M6x1 tap.	12,5	6	20,5	26	10	10	NBR	Brass	300	4 350	2 000	4.41
455-565-068-VS	PUSH-IN FITT. WEDK 6-R1/4K FPM	6	R 1/4	12,5	11	24,5	26	14	10	NBR	Brass	300	4 350	2 900	6.39

## Locking pin

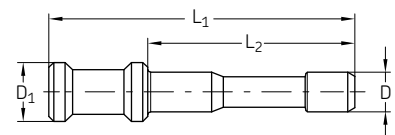

Order number	Designation	Tube Ø	D <sub>1</sub>	L <sub>1</sub>	L <sub>2</sub>	Material	Operating pressure max.		Weight (100 pcs)	
							bar	psi	g	lb
450-204-002	CLOSURE PLUG D4 MS FOR PUSH-IN FITT.	4	6	31	21	Brass	300	4 350	300	0.66
450-206-002	CLOSURE PLUG D6 MS FOR PUSH-IN FITT.	6	8	37	25	Brass	300	4 350	800	1.76

## Manifolds



### Description

Manifolds are designed for the installation of one or several metering devices, restrictors or lubrication point lines and enable direct main line connection. They are often used with the 341, 351 and 361 series single-line metering devices or VD screw-in flow restrictors. Manifolds are available for various main-line connections, such as M8×1, M10×1 and M14×1.5 threads. The number of outlet ports varies from 1 to 10 (on request up to 20) with threads of M8×1 and M10×1. The seal is made via an O-ring or sealing washer (copper).

### Features and benefits

- Wide selection of connection options and variants
- Available in aluminum; galvanized steel available on request
- Easy and quick system extension/reduction

### Applications

- Automotive Industry
- General industry
- Machine tools
- Etc.

# Metering device manifolds

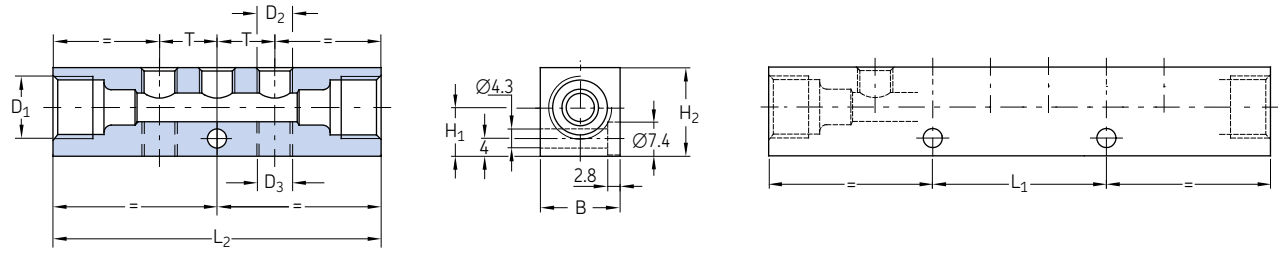

Order number	Designation	Main $D_1$		$D_2$ above	$D_3$ below	$L_1$	$L_2$	$H_1$	$H_2$	$B$	$T$	Material	Weight		
		mm	mm										mm	mm	mm
VL-01EAM3	MET.DEV.BAR,AL M10x1 1x M10x1	6	M10x1	1x	M10x1 -	-	41	11	20	18	-	Aluminum alloy	40	0.09	
VL-02EAM3	MET.DEV.BAR,AL M10x1 2x M10x1	6	M10x1	2x	M10x1 -	-	58	11	20	18	17	Aluminum alloy	50	0.11	
VL-03EAM3	MET.DEV.BAR,AL M10x1 3x M10x1	6	M10x1	3x	M10x1 -	-	75	11	20	18	17	Aluminum alloy	60	0.13	
VL-04EAM3	MET.DEV.BAR,AL M10x1, 4x M10x1	6	M10x1	4x	M10x1 -	34	92	11	20	18	17	Aluminum alloy	78	0.17	
VL-05EAM3	MET.DEV.BAR,AL M10x1 5x M10x1	6	M10x1	5x	M10x1 -	51	109	11	20	18	17	Aluminum alloy	90	0.20	
VL-06EAM3	MET.DEV.BAR,AL M10x1 6x M10x1	6	M10x1	6x	M10x1 -	68	126	11	20	18	17	Aluminum alloy	100	0.22	
VL-08EAM3	MET.DEV.BAR,AL M10x1 8x M10x1	6	M10x1	8x	M10x1 -	52	160	11	20	18	17	Aluminum alloy	135	0.30	
VL-10EAM3	MET.DEV.BAR,AL M10x1 10x M10x1	6	M10x1	10x	M10x1 -	136	194	11	20	18	17	Aluminum alloy	162	0.36	
322-861	MET.DEV.BAR,AL M10x1 2x1x M10x1	6	M10x1	1x	M10x1 1x	M10x1	-	41	11	20	18	-	Aluminum alloy	30	0.07
324-861	MET.DEV.BAR,AL M10x1 2x2x M10x1	6	M10x1	2x	M10x1 2x	M10x1	-	58	11	20	18	18	Aluminum alloy	50	0.11
326-663	MET.DEV.BAR,AL M10x1 2x3x M10x1	6	M10x1	3x	M10x1 3x	M10x1	52	77	11	17	18	18	Aluminum alloy	60	0.13
328-861	MET.DEV.BAR,AL M10x1 2x4x M10x1	6	M10x1	4x	M10x1 4x	M10x1	34	92	11	20	18	18	Aluminum alloy	70	0.15
330-861	MET.DEV.BAR,AL M10x1 2x5x M10x1	6	M10x1	5x	M10x1 5x	M10x1	51	109	11	20	18	18	Aluminum alloy	80	0.18
332-861	MET.DEV.BAR,AL M10x1 2x6x M10x1	6	M10x1	6x	M10x1 6x	M10x1	68	126	11	20	18	18	Aluminum alloy	96	0.21
334-861	MET.DEV.BAR,AL M10x1 2x7x M10x1	6	M10x1	7x	M10x1 7x	M10x1	85	143	11	20	18	18	Aluminum alloy	108	0.24
336-861	MET.DEV.BAR,AL M10x1 2x8x M10x1	6	M10x1	8x	M10x1 8x	M10x1	102	160	11	20	18	18	Aluminum alloy	128	0.28
338-861	MET.DEV.BAR,AL M10x1 2x9x M10x1	6	M10x1	9x	M10x1 9x	M10x1	119	177	11	20	18	18	Aluminum alloy	137	0.30
340-861	MET.DEV.BAR,AL M10x1 2x10x M10x1	6	M10x1	10x	M10x1 10x	M10x1	136	194	11	20	18	18	Aluminum alloy	140	0.31
VL-01DAM3	MET.DEV.BAR,AL M10x1 1x M8x1	6	M10x1	1x	M8x1 -	-	39	10,5	17	13	-	Aluminum alloy	20	0.04	
VL-02DAM3	MET.DEV.BAR,AL M10x1 2x M8x1	6	M10x1	2x	M8x1 -	-	52	10,5	17	13	13	Aluminum alloy	30	0.07	
VL-03DAM3	MET.DEV.BAR,AL M10x1 1x M8x1	6	M10x1	3x	M8x1 -	-	65	10,5	17	13	13	Aluminum alloy	30	0.07	
VL-04DAM3	MET.DEV.BAR,AL M10x1 3x M8x1	6	M10x1	4x	M8x1 -	-	78	10,5	17	13	13	Aluminum alloy	38	0.08	
VL-05DAM3	MET.DEV.BAR,AL M10x1 4x M8x1	6	M10x1	5x	M8x1 -	-	91	10,5	17	13	13	Aluminum alloy	40	0.09	
VL-06DAM3	MET.DEV.BAR,AL M10x1 6x M8x1	6	M10x1	6x	M8x1 -	52	104	11	20	18	13	Aluminum alloy	50	0.11	
VL-08DAM3	MET.DEV.BAR,AL M10x1 8x M8x1	6	M10x1	8x	M8x1 -	52	130	10,5	17	13	13	Aluminum alloy	65	0.14	
VL-10DAM3	MET.DEV.BAR,AL M10x1 10x M8x1	6	M10x1	10x	M8x1 -	78	156	10,5	17	13	13	Aluminum alloy	80	0.18	
321-581	MET.DEV.BAR,AL M14x1,5 1x M8x1	8	M14x1,5	1x	M8x1 -	-	48	-	20	18	-	Aluminum alloy	40	0.09	
322-581	MET.DEV.BAR,AL M14x1,5 2x M8x1	8	M14x1,5	2x	M8x1 -	-	61	11	20	18	13	Aluminum alloy	47	0.10	
323-581	MET.DEV.BAR,AL M14x1,5 3x M8x1	8	M14x1,5	3x	M8x1 -	-	74	11	20	18	13	Aluminum alloy	50	0.11	
324-581	MET.DEV.BAR,AL M14x1,5 4x M8x1	8	M14x1,5	4x	M8x1 -	-	87	11	20	18	13	Aluminum alloy	55	0.12	
325-581	MET.DEV.BAR,AL M14x1,5 5x M8x1	8	M14x1,5	5x	M8x1 -	-	74	11	20	18	13	Aluminum alloy	70	0.15	
326-581	MET.DEV.BAR,AL M14x1,5 6x M8x1	8	M14x1,5	6x	M8x1 -	39	113	11	20	18	13	Aluminum alloy	90	0.20	
328-581	MET.DEV.BAR,AL M14x1,5 8x M8x1	8	M14x1,5	8x	M8x1 -	65	139	11	20	18	13	Aluminum alloy	110	0.24	
330-581	MET.DEV.BAR,AL M14x1,5 10x M8x1	8	M14x1,5	10x	M8x1 -	91	165	11	20	18	13	Aluminum alloy	135	0.30	

## Tubes and hoses



### Description

Pipe and hose lines are an important connecting element in all lubrication systems. The lubricant is transported by them from the pump via the metering device to the lubrication points.

The following chapter lists the suitable pipe and hose material for all SKF lubrication systems.

This criteria must be considered when selecting:

- Pipe dimension (inside diameter and wall thickness): Selection according to the occurring pressures and pressure drops
- Material or surface protection of the steel pipes

Material for steel pipes: precision hydraulic pipe seamless to EN 10305-4 in galvanized Cr-6-free or stainless steel material 1.4571 for aggressive conditions (sea water, cleaning agents, paper machines).

Material for plastic pipes Polyamide: PA12H (natural, semi-rigid), PA12HL (black, semi-rigid), PA12PH (natural, flexible), PA12PHL (black, flexible).

### Features and benefits

- Reliable and long-term lubricant transfer solutions for low-, medium- and high-pressure lubrication systems
- Quick installation as pipes/hoses are pre-filled with lubricant
- Wide range of available versions

### Applications

- Paper and packaging industry
- Food and beverage industry
- Construction machines
- Agriculture machines
- Oil and gas industry
- Renewable energy
- Material handling
- On-road trucks
- Etc.

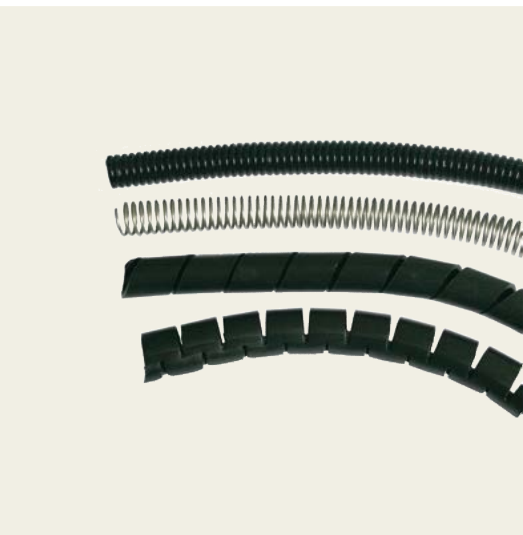

## Fixing material

SKF offers a wide range of tube-fixing material, such as fixing clips, pipe brackets, cable straps, mounting bases and fixing bolts, which are suitable for tubes typically used in lubrication systems. For more details, please see the chapter on fixing material.

## Tools

SKF has a variety of tools that help assemble tubes and hoses in all kinds of systems, such as:

- Tube bending device (for the bending of metal tubes)
- Pipe cutter (for cutting metal tubes and producing a claw groove for quick connection fittings)

For more information, please see the chapter on tools.

## Tube protections

SKF offers a range of solutions for tube protection including coils, protective helixes or corrugated hoses. For more details, please see page 103.

## Tubes and hoses

# Plastic tubing

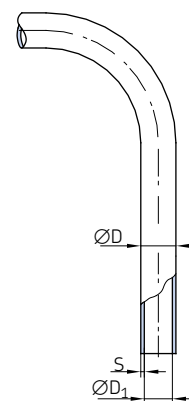

Order number	Designation	Tube outside ØD	Wall thickness S	Min. bending radius <sup>1)</sup> R	Burst pressure <sup>2)</sup>		Material	Weight (100 m)	
					bar	psi		kg	lb
Plastic tubing semirigid (without plasticizer)									
WVN715-R02.5X0.5	TUBE,PA12H 2,5x0,5 NATUR	2,5	0,5	25	198	2 872	PA12H	0,33	0.73
WVN715-R04X0.85	TUBE,PA12H 4,0x0,85 NATUR	4	0,85	38	216	3 132	PA12H	0,88	1.94
WVN715R04X0.85+A89	TUBE,PA12HL 4,0x0,85 BLACK	4	0,85	38	216	3 132	PA12HL	0,88	1.94
112-35127-7	TUBE, PA12HL 4,0x1,0 BLACK	4	1	30	267	3 872	PA12HL	0,9	1.98
112-35127-5	TUBE,PA12HL 4,0x1,0 NATUR	4	1	30	267	3 872	PA12HL	0,9	1.98
WVN715-R06X1	TUBE,PA12H 6,0x1,0 NATUR	6	1	63	159	2 306	PA12H	1,61	3.55
WVN715-R06X1.25	TUBE,PA12H 6,0x1,25 NATUR	6	1,25	63	210	3 045	PA12H	1,92	4.23
WVN715R06X1.25+A89	TUBE,PA12HL 6,0x1,25 BLACK	6	1,25	63	210	3 045	PA12HL	2,16	4.76
112-35127-2	TUBE,PA12HL 6,0x1,5 BLACK	6	1,5	40	267	3 872	PA12HL	2,29	5.05
WVN715-R08x1.25	TUBE,PA12H 8,0x1,25 NATUR	8	1,25	76	147	2 132	PA12H	2,73	6.02
WVN715-R010X1.5	TUBE,PA12H 10,0x1,5 NATUR	10	1,5	89	141	2 045	PA12H	4,12	9.08
WVN715R010X1.5+A89	TUBE,PA12HL 10,0x1,5 BLACK	10	1,5	89	141	2 045	PA12HL	4,12	9.08
Plastic tubing flexible (containing plasticizer)									
WVN716-R04X0.85	TUBE,PA12PH 4,0x0,85 NATUR	4	0,85	38	108	1 566	PA12PH	0,53	1.17
WVN716R04X0.85+A89	TUBE,PA12PHL 4,0x0,85 BLACK	4	0,85	38	108	1 566	PA12PHL	0,53	1.17
112-35225-4	TUBE,PA12PHL 4,0x1,0 BLACK	4	1	27	132	1 924	PA12PHL	0,63	1.39
WVN716-R06X1.25	TUBE,PA12PH 6,0x1,25 NATUR	6	1,25	63	105	1 522	PA12PH	2	4.41
WVN716R06X1.25+A89	TUBE,PA12PHL 6,0x1,25 BLACK	6	1,25	63	105	1 522	PA12PHL	2	4.41
WVN716-R08X1.25	TUBE,PA12PH 8,0x1,25 NATUR	8	1,25	80	75	1 087	PA12PH	2,8	6.17

<sup>1)</sup> without bending device  
<sup>2)</sup> the permissible burst pressure is lower at higher temperatures (→ pressure utilization factor table).

### Pressure utilization factor

Temperature up to °C	Pressure efficiency %
23	100
30	83
40	72
50	64
60	57
70	52
80	47

The pressure utilization factor indicates the percentage utilization of effective stress available in the specified temperature ranges, based on 23 °C.

### Technical Data

Material	PA 12 H polyamide 12, semirigid, unplasticized as per DIN 73378, stabilized against heat and aging.	PA 12 HL (black tubing) polyamide 12, semirigid, unplasticized as per DIN 73378, stabilized against light, heat and aging.
	PA 12 PH polyamide 12, flexible, containing plasticizer as per DIN 73378, stabilized against heat and aging.	PA 12 PHL (black tubing) polyamide 12, flexible, containing plasticizer as per DIN 73378, stabilized against light, heat, and aging.
Temperature range	-60 to +80 °C	-60 to +80 °C

# Tube and hose protections



Order number	Designation	Ø	Material	Weight		
				g	lb	
per linear meter				mm		
<b>Corrugated tube</b>						
<b>982-760-120</b>	TUBE,CORRUGATED PA6 NW8	BLACK	8,4	Polyamide 6, black colour	20	0.04
<b>982-760-130</b>	TUBE,CORRUGATED PA6 NW10	BLACK	10	Polyamide 6, black colour	26	0.06
<b>982-760-160</b>	TUBE,CORRUGATED PA6 NW12	BLACK	12,3	Polyamide 6, black colour	34	0.07
<b>Spring coil</b>						
<b>982-760-122</b>	SPRING COIL DI6,1xD1,2 1.4310		6,1	Stainless steel 1.4310	64	0.14
<b>982-760-132</b>	SPRING COIL DI10,6xD1,2 1.4310		10,6	Stainless steel 1.4310	64	0.14
<b>982-760-142</b>	SPRING COIL DI13,5xD1,5 1.4310		12,5	Stainless steel 1.4310	64	0.14
<b>111-35306-5</b>	SPRING COIL DI17XD1,8 1.4310		17	Stainless steel 1.4310	290	0.64
<b>Plastic helix</b>						
<b>113-35075-2</b>	PLASTIC HELIX GR. 6 BLACK		5-20	Polyethylene, black colour	13	0.03
<b>113-35075-3</b>	PLASTIC HELIX GR.12 BLACK		9-30	Polyethylene, black colour	48	0.11
<b>Spiral hose slotted</b>						
<b>982-760-102</b>	SPIRAL HOSE PP NW8 SLOTTED		6-9	Polypropylene	25	0.06
<b>982-760-172</b>	SPIRAL HOSE PP NW15 SLOTTED		10-16	Polypropylene	100	0.22

Tubes and hoses

# Steel tubing

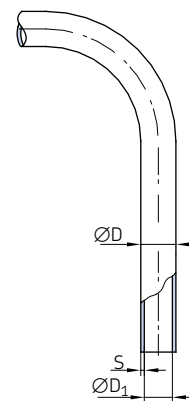

Order number	Designation	ØD	D <sub>1</sub>	Material	Operating pressure max.		Weight	
					bar	psi	kg/m	lb/m
		mm	mm					
982-120-041	TUBE, E235+N D 4,0x 0,7 CF	4	2,6	Steel tubing, galvanized surface (Cr-6 free)	368	5 340	0,063	0.14
982-120-040	TUBE, E235+N D 4,0x 1,0 CF	4	2	Steel tubing, galvanized surface (Cr-6 free)	500	7 250	0,074	0.16
982-120-061	TUBE, E235+N D 6,0x 0,7 CF	6	4,6	Steel tubing, galvanized surface (Cr-6 free)	333	4 830	0,12	0.26
105-35251-1	TUBE, E235+N D 6,0x 1,0 CF	6	4	Steel tubing, galvanized surface (Cr-6 free)	372	5 390	0,123	0.27
105-35251-3	TUBE, E235+N D 8,0x 1,0 CF	8	6	Steel tubing, galvanized surface (Cr-6 free)	333	4 830	0,173	0.38
982-120-100	TUBE, E235+N D 10,0x 1,0 CF	10	8	Steel tubing, galvanized surface (Cr-6 free)	282	4 090	0,222	0.49
105-35025-5	TUBE, E235+N D 10,0x 1,5 CF	10	7	Steel tubing, galvanized surface (Cr-6 free)	373	5 410	0,314	0.69
105-35134-3	TUBE, E235+N D 12,0x 1,5 CF	12	9	Steel tubing, galvanized surface (Cr-6 free)	353	5 120	0,388	0.86
105-35134-9	TUBE, E235+N D 15,0x 1,5 CF	15	12	Steel tubing, galvanized surface (Cr-6 free)	282	4 090	0,499	1.1
105-35183-3	TUBE, E235+N D 16,0x 2,0 CF	16	12	Steel tubing, galvanized surface (Cr-6 free)	353	5 120	0,691	1.52
982-120-180	TUBE, E235+N D 18,0x 1,0 CF	18	15	Steel tubing, galvanized surface (Cr-6 free)	157	2 280	0,61	1.35
105-35134-1	TUBE, E235+N D 20,0x 2,0 CF	20	16	Steel tubing, galvanized surface (Cr-6 free)	282	4 090	0,888	1.96
105-35308-1	TUBE, E235+N D 28,0x 2,0 CF	28	24	Steel tubing, galvanized surface (Cr-6 free)	201	2 910	1,282	2.83
105-35134-4	TUBE, E235+N D 30,0x 3,0 CF	30	24	Steel tubing, galvanized surface (Cr-6 free)	282	4 090	1,998	4.41



## Tubes and hoses

# Stainless steel tubing

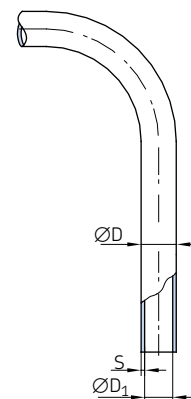

Order number	Designation	ØD	D <sub>1</sub>	Material	Operating pressure max.		Weight		
					bar	psi	kg/m	lb/m	
		mm	mm						
<b>D1127R02.5x0.5+A46</b>	TUBE, NIRO 1.4301 D 2,5x0,5	2,5	1,5	Stainless steel (material 1.4301/1.4306)	386	5 600	0,042	0,09	
<b>DIN2462-R04x1+A46</b>	TUBE, NIRO 1.4301 D 4,0x1,0	4	2	Stainless steel (material 1.4301/1.4306)	466	6 760	0,075	0,17	
<b>106-35203-4</b>	TUBE, NIRO 1.4571 D 6,0x1,0	6	4	Stainless steel 1.4571	426	6 180	0,125	0,28	
<b>106-35203-3</b>	TUBE, NIRO 1.4571 D 8,0x1,0	8	6	Stainless steel 1.4571	368	5 340	0,169	0,37	
<b>DIN2462-R010x1+A46</b>	TUBE, NIRO 1.4301 D 10,0x1,0	10	8	Stainless steel (material 1.4301/1.4306)	231	3 350	0,225	0,5	
<b>106-35203-2</b>	TUBE, NIRO 1.4571 D 10,0x1,5	10	7	Stainless steel 1.4571	389	5 640	0,319	0,7	
<b>106-35203-1</b>	TUBE, NIRO 1.4571 D 20,0x2,0	20	16	Stainless steel 1.4571	294	4 260	0,901	1,99	
<b>106-35292-2</b>	TUBE, NIRO 1.4571 D 22,0x2,0	22	18	Stainless steel 1.4571	267	3 870	1,002	2,21	
<b>106-35292-1</b>	TUBE, NIRO 1.4571 D 28,0x2,0	28	24	Stainless steel 1.4571	210	3 050	1,302	2,87	
<b>106-35203-7</b>	TUBE, NIRO 1.4571 D 30,0x3,0	30	24	Stainless steel 1.4571	294	4 260	2,028	4,47	
<b>106-35231-1</b>	TUBE, NIRO 1.4301 D 6,0x1,0	6	4	Stainless steel 1.4301	400	5 800	0,123	0,27	
<b>106-35231-2</b>	TUBE, NIRO 1.4301 D 8,0x1,0	8	6	Stainless steel 1.4301	310	4 500	0,17	0,37	
<b>106-35231-3</b>	TUBE, NIRO 1.4301 D 10,0x1,5	10	7	Stainless steel 1.4301	365	5 290	0,315	0,69	
<b>106-35231-6</b>	TUBE, NIRO 1.4301 D 20,0x2,0	20	16	Stainless steel 1.4301	253	3 670	0,888	1,96	
<b>106-35267-4</b>	TUBE, NIRO 1.4301 D 22,0x2,0	22	18	Stainless steel 1.4301	232	3 360	0,986	2,17	

## Tubes and hoses

# Low-pressure hoses for main lines max. 45 bar with pipe stud on both ends

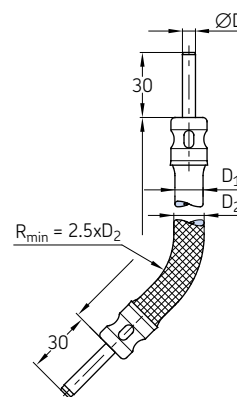

Order number	Designation <sup>1)</sup>	Tube ØD	Length	Rubber ØD <sub>1</sub>	Metal braided D <sub>2</sub>	Max. increase in volume at 80 bar	Weight	
		mm	mm	mm	mm	cm <sup>3</sup> /m	g	lb
Low-pressure hoses with pipe stud Ø4 mm								
<b>714-180</b>	HOSE,CR 45 DN 3x 180,STU 4	4	180	11	–	2,5	39	0.09
<b>714-220</b>	HOSE,CR 45 DN 3x 220,STU 4	4	220	11	–	2,5	43	0.09
<b>714-260</b>	HOSE,CR 45 DN 3x 260,STU 4	4	260	11	–	2,5	48	0.11
<b>714-300</b>	HOSE,CR 45 DN 3x 300,STU 4	4	300	11	–	2,5	57	0.13
<b>714-380</b>	HOSE,CR 45 DN 3x 380,STU 4	4	380	11	–	2,5	61	0.13
<b>714-420</b>	HOSE,CR 45 DN 3x 420,STU 4	4	420	11	–	2,5	70	0.15
<b>714-450</b>	HOSE,CR 45 DN 3x 450,STU 4	4	450	11	–	2,5	74	0.16
<b>714-500</b>	HOSE,CR 45 DN 3x 500,STU 4	4	500	11	–	2,5	84	0.19
<b>714-580</b>	HOSE,CR 45 DN 3x 580,STU 4	4	580	11	–	2,5	92	0.20
Low-pressure hoses with pipe stud Ø4 mm and metal braid								
<b>714-180-M</b>	HOSE,CR 45 DN 3x 180,STU 4 MET.BRAID.	4	180	11	12	2,5	56	0.12
<b>714-260-M</b>	HOSE,CR 45 DN 3x 260,STU 4 MET.BRAID.	4	260	11	12	2,5	69	0.15
<b>714-300-M</b>	HOSE,CR 45 DN 3x 300,STU 4 MET.BRAID.	4	300	11	12	2,5	75	0.17
<b>714-400-M</b>	HOSE,CR 45 DN 3x 400,STU 4 MET.BRAID.	4	400	11	12	2,5	97	0.21
<b>714-500-M</b>	HOSE,CR 45 DN 3x 500,STU 4 MET.BRAID.	4	500	11	12	2,5	119	0.26
<b>714-580-M</b>	HOSE,CR 45 DN 3x 580,STU 4 MET.BRAID.	4	580	11	12	2,5	167	0.37
Low-pressure hoses with pipe stud Ø6 mm								
<b>716-220</b>	HOSE,CR 45 DN 4,5x 220,STU 6	6	220	13	–	3,6	64	0.14
<b>716-300</b>	HOSE,CR 45 DN 4,5x 300,STU 6	6	300	13	–	3,6	72	0.16
<b>716-340</b>	HOSE,CR 45 DN 4,5x 340,STU 6	6	340	13	–	3,6	79	0.17
<b>716-380</b>	HOSE,CR 45 DN 4,5x 380,STU 6	6	380	13	–	3,6	86	0.19
<b>716-420</b>	HOSE,CR 45 DN 4,5x 420,STU 6	6	420	13	–	3,6	90	0.20
<b>716-500</b>	HOSE,CR 45 DN 4,5x 500,STU 6	6	500	13	–	3,6	101	0.22
<b>716-580</b>	HOSE,CR 45 DN 4,5x 580,STU 6	6	580	13	–	3,6	128	0.28
Low-pressure hoses with pipe stud Ø6 mm and metal braid								
<b>716-300-M</b>	HOSE,CR 45 DN 4,5x 300,STU6 MET.BRAID.	6	300	13	14	3,6	108	0.24
<b>716-400-M</b>	HOSE,CR 45 DN 4,5x 400,STU6 MET.BRAID.	6	400	13	14	3,6	140	0.31
<b>716-500-M</b>	HOSE,CR 45 DN 4,5x 500,STU6 MET.BRAID.	6	500	13	14	3,6	165	0.36
Low-pressure hoses with pipe stud Ø8 mm								
<b>718-340</b>	HOSE,CR 45 DN 6,5x 340,STU 8	8	340	15	–	4,4	117	0.26
<b>718-450</b>	HOSE,CR 45 DN 6,5x 450,STU 8	8	450	15	–	4,4	133	0.29
<b>718-580</b>	HOSE,CR 45 DN 6,5x 580,STU 8	8	580	15	–	4,4	141	0.31
Low-pressure hoses with pipe stud Ø8 mm and metal braid								
<b>718-400-M</b>	HOSE,CR 45 DN 6,5x 400,STU 8 MET.BRAID.	8	400	15	16	4,4	136	0.30
<b>718-500-M</b>	HOSE,CR 45 DN 6,5x 500,STU 8 MET.BRAID.	8	500	15	16	4,4	174	0.38

<sup>1)</sup> Material hose: mineral oil resistant CR rubber inside; 2 layers of braided rayon, outside rubber conditionally oil resistant, resistant to light cracks and ozone.  
Material metal braid: galvanized steel wire; tube ends: galvanized steel pipe.

# Low-pressure hoses for main lines max. 45 bar with tapered sleeve and socket union on both ends

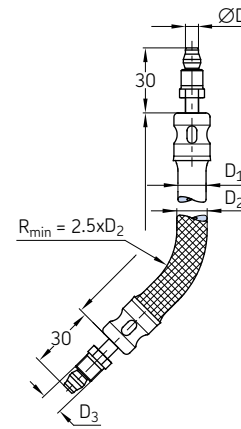

Order number	Designation <sup>1)</sup>	Tube ØD	Length	Rubber ØD <sub>1</sub>	Metal braided D <sub>2</sub>	Thread D <sub>3</sub>	Max. increase in volume at 80 bar	Weight	
		mm	mm	mm	mm	mm	cm <sup>3</sup> /m	g	lb
Low-pressure hoses with tapered sleeve socket union									
714-180-K	HOSE,CR 45 DN 3x 180,M8x1	4	180	11	–	M8x1	2,5	45	0.10
714-220-K	HOSE,CR 45 DN 3x 220,M8x1	4	220	11	–	M8x1	2,5	49	0.11
714-260-K	HOSE,CR 45 DN 3x 260,M8x1	4	260	11	–	M8x1	2,5	53	0.12
714-300-K	HOSE,CR 45 DN 3x 300,M8x1	4	300	11	–	M8x1	2,5	59	0.13
714-380-K	HOSE,CR 45 DN 3x 380,M8x1	4	380	11	–	M8x1	2,5	68	0.15
714-420-K	HOSE,CR 45 DN 3x 420,M8x1	4	420	11	–	M8x1	2,5	76	0.17
714-450-K	HOSE,CR 45 DN 3x 450,M8x1	4	450	11	–	M8x1	2,5	84	0.19
714-500-K	HOSE,CR 45 DN 3x 500,M8x1	4	500	11	–	M8x1	2,5	90	0.20
714-580-K	HOSE,CR 45 DN 3x 580,M8x1	4	580	11	–	M8x1	2,5	100	0.22
Low-pressure hoses with tapered sleeve socket union and metal braid									
714-180-MK	HOSE,CR 45 DN 3x 180,M8x1 MET.BRAID.	4	180	11	12	M8x1	2,5	63	0.14
714-260-MK	HOSE,CR 45 DN 3x 260,M8x1 MET.BRAID.	4	260	11	12	M8x1	2,5	80	0.18
714-300-MK	HOSE,CR 45 DN 3x 300,M8x1 MET.BRAID.	4	300	11	12	M8x1	2,5	85	0.19
714-400-MK	HOSE,CR 45 DN 3x 400,M8x1 MET.BRAID.	4	400	11	12	M8x1	2,5	110	0.24
714-500-MK	HOSE,CR 45 DN 3x 500,M8x1 MET.BRAID.	4	500	11	12	M8x1	2,5	120	0.26
714-580-MK	HOSE,CR 45 DN 3x 580,M8x1 MET.BRAID.	4	580	11	12	M8x1	2,5	140	0.31
Low-pressure hoses with tapered sleeve socket union									
716-220-K	HOSE,CR 45 DN 4,5x 220,M10x1	6	220	13	–	M10x1	3,6	68	0.15
716-300-K	HOSE,CR 45 DN 4,5x 300,M10x1	6	300	13	–	M10x1	3,6	80	0.18
716-340-K	HOSE,CR 45 DN 4,5x 340,M10x1	6	340	13	–	M10x1	3,6	85	0.19
716-380-K	HOSE,CR 45 DN 4,5x 380,M10x1	6	380	13	–	M10x1	3,6	92	0.20
716-420-K	HOSE,CR 45 DN 4,5x 420,M10x1	6	420	13	–	M10x1	3,6	98	0.22
716-500-K	HOSE,CR 45 DN 4,5x 500,M10x1	6	500	13	–	M10x1	3,6	113	0.25
716-580-K	HOSE,CR 45 DN 4,5x 580,M10x1	6	580	13	–	M10x1	3,6	127	0.28
Low-pressure hoses with tapered sleeve socket union and metal braid									
716-300-MK	HOSE,CR 45 DN 4,5x 300,M10x1 MET.BRAID.	6	300	13	14	M10x1	3,6	110	0.24
716-400-MK	HOSE,CR 45 DN 4,5x 400,M10x1 MET.BRAID.	6	400	13	14	M10x1	3,6	140	0.31
716-450-MK	HOSE,CR 45 DN 4,5x 450,M10x1 MET.BRAID.	6	450	13	14	M10x1	3,6	160	0.35
716-500-MK	HOSE,CR 45 DN 4,5x 500,M10x1 MET.BRAID.	6	500	13	14	M10x1	3,6	180	0.40
Low-pressure hoses with tapered sleeve socket union									
718-400-K	HOSE,CR 45 DN 6,5x 400,M14x1,5	8	340	15	–	M14x1,5	4,4	116	0.26
718-450-K	HOSE,CR 45 DN 6,5x 450,M14x1,5	8	450	15	–	M14x1,5	4,4	147	0.32
718-500-K	HOSE,CR 45 DN 6,5x 500,M14x1,5	8	580	15	–	M14x1,5	4,4	164	0.36
Low-pressure hoses with tapered sleeve socket union and metal braid									
718-400-MK	HOSE,CR 45 DN6,5x 400,M14x1,5 MET.BRAID.	8	400	15	16	M14x1,5	4,4	160	0.35
718-450-MK	HOSE,CR 45 DN6,5x 450,M14x1,5 MET.BRAID.	8	450	15	16	M14x1,5	4,4	195	0.43
718-500-MK	HOSE,CR 45 DN6,5x 500,M14x1,5 MET.BRAID.	8	500	15	16	M14x1,5	4,4	221	0.49

<sup>1)</sup> Material hose: mineral oil resistant CR rubber inside; 2 layers of braided rayon, outside rubber conditionally oil resistant, resistant to light cracks and ozone.  
Material metal braid: galvanized steel wire; tube ends: galvanized steel tubing.

## Tubes and hoses

Low-pressure hoses for main lines max. 45 bar with pipe stud on both ends and with claw groove for quick connectors

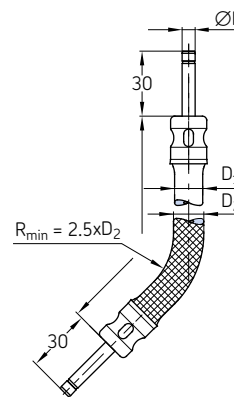

Order number	Designation <sup>1)</sup>	Tube ØD	Length	Rubber ØD <sub>1</sub>	Metal braided D <sub>2</sub>	Max. increase in volume at 80 bar	Weight	
		mm	mm	mm	mm	cm <sup>3</sup> /m	g	lb
Low-pressure hoses with pipe stud Ø4 mm with claw groove for quick connectors								
714-180-VS	HOSE,CR 45 DN 3x 180,VS	4	180	11	–	2,5	39	0.09
714-220-VS	HOSE,CR 45 DN 3x 220,VS	4	220	11	–	2,5	43	0.09
714-260-VS	HOSE,CR 45 DN 3x 260,VS	4	260	11	–	2,5	48	0.11
714-300-VS	HOSE,CR 45 DN 3x 300,VS	4	300	11	–	2,5	57	0.13
714-380-VS	HOSE,CR 45 DN 3x 380,VS	4	380	11	–	2,5	61	0.13
714-420-VS	HOSE,CR 45 DN 3x 420,VS	4	420	11	–	2,5	70	0.15
714-450-VS	HOSE,CR 45 DN3x 450,VS	4	450	11	–	2,5	74	0.16
714-500-VS	HOSE,CR 45 DN 3x 500,VS	4	500	11	–	2,5	84	0.19
714-580-VS	HOSE,CR 45 DN 3x 580,VS	4	580	11	–	2,5	92	0.20
Low-pressure hoses with pipe stud Ø4 mm with claw groove for quick connectors and metal braid								
714-180-M-VS	HOSE,CR 45 DN 3x 180,VS MET.BRAID.	4	180	11	12	2,5	56	0.12
714-260-M-VS	HOSE,CR 45 DN 3x 260,VS MET.BRAID.	4	260	11	12	2,5	69	0.15
714-300-M-VS	HOSE,CR 45 DN 3x 300,VS MET.BRAID.	4	300	11	12	2,5	75	0.17
714-400-M-VS	HOSE,CR 45 DN 3x 400,VS MET.BRAID.	4	400	11	12	2,5	97	0.21
714-500-M-VS	HOSE,CR 45 DN 3x 500,VS MET.BRAID.	4	500	11	12	2,5	119	0.26
714-580-M-VS	HOSE,CR 45 DN 3x 580,VS MET.BRAID.	4	580	11	12	2,5	167	0.37
Low-pressure hoses with pipe stud Ø6 mm with claw groove for quick connectors								
716-220-VS	HOSE,CR 45 DN 4,5x 220,VS	6	220	13	–	3,6	64	0.14
716-300-VS	HOSE,CR 45 DN 4,5x 300,VS	6	300	13	–	3,6	72	0.16
716-380-VS	HOSE,CR 45 DN 4,5x 380,VS	6	380	13	–	3,6	86	0.19
716-420-VS	HOSE,CR 45 DN 4,5x 420,VS	6	420	13	–	3,6	90	0.20
716-500-VS	HOSE,CR 45 DN 4,5x 500,VS	6	500	13	–	3,6	101	0.22
716-580-VS	HOSE,CR 45 DN 4,5x 580,VS	6	580	13	–	3,6	128	0.28
Low-pressure hoses with pipe stud Ø6 mm with claw groove for quick connectors and metal braid								
716-300-M-VS	HOSE,CR 45 DN 4,5x 300,VS MET.BRAID.	6	300	13	14	3,6	108	0.24
716-400-M-VS	HOSE,CR 45 DN 4,5x 400,VS MET.BRAID.	6	400	13	14	3,6	140	0.31
716-450-M-VS	HOSE,CR 45 DN 4,5x 450,VS MET.BRAID.	6	450	13	14	3,6	155	0.34
716-500-M-VS	HOSE,CR 45 DN 4,5x 500,VS MET.BRAID.	6	500	13	14	3,6	165	0.36
Low-pressure hoses with pipe stud Ø8 mm with claw groove for quick connectors								
718-340-VS	HOSE,CR 45 DN 6,5x 340,VS	8	340	15	–	4,4	117	0.26
718-450-VS	HOSE,CR 45 DN 6,5x 450,VS	8	450	15	–	4,4	133	0.29
718-580-VS	HOSE,CR 45 DN 6,5x 580,VS	8	580	15	–	4,4	141	0.31
Low-pressure hoses with pipe stud Ø8 mm with claw groove for quick connectors and metal braid								
718-400-M-VS	HOSE,CR 45 DN 6,5x 400,VS MET.BRAID.	8	400	15	16	4,4	136	0.30
718-450-M-VS	HOSE,CR 45 DN 6,5x 450,VS MET.BRAID.	8	450	15	16	4,4	157	0.35
718-500-M-VS	HOSE,CR 45 DN 6,5x 500,VS MET.BRAID.	8	500	15	16	4,4	174	0.38

<sup>1)</sup> Material hose: mineral oil resistant CR rubber inside; 2 layers of braided rayon, outside rubber conditionally oil resistant, resistant to light cracks and ozone.  
Material metal braid: galvanized steel wire; tube ends: galvanized steel pipe.

## Low-pressure hoses for secondary lines max. 15 bar with pipe stud on both ends

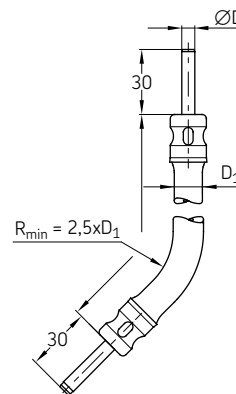

Order number	Designation <sup>1)</sup>	Tube	Length	Rubber	Weight	
		ØD	mm	ØD <sub>1</sub>	g	lb
734-180	HOSE,CR 15 DN 3x 180,STU 4	4	180	8,8	30	0,07
734-220	HOSE,CR 15 DN 3x 220,STU 4	4	220	8,8	33	0,07
734-260	HOSE,CR 15 DN 3x 260,STU 4	4	260	8,8	37	0,08
734-300	HOSE,CR 15 DN 3x 300,STU 4	4	300	8,8	40	0,09
734-380	HOSE,CR 15 DN 3x 380,STU 4	4	380	8,8	45	0,10
734-420	HOSE,CR 15 DN 3x 420,STU 4	4	420	8,8	47	0,10
734-450	HOSE,CR 15 DN 3x 450,STU 4	4	450	8,8	48	0,11
734-500	HOSE,CR 15 DN 3x 500,STU 4	4	500	8,8	58	0,13
734-580	HOSE,CR 15 DN 3x 580,STU 4	4	580	8,8	61	0,13

<sup>1)</sup> Material hose: mineral oil resistant CR rubber inside; 2 layers of braided rayon, outside rubber conditionally oil resistant, resistant to light cracks and ozone.  
Material metal braid: galvanized steel wire; tube ends: galvanized steel pipe.

## Low-pressure hoses for secondary lines max. 15 bar with tapered sleeve and socket union on both ends

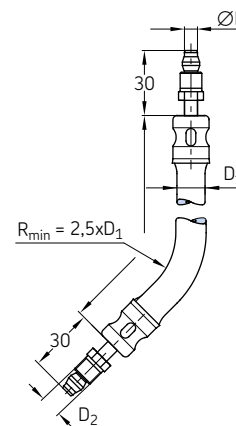

Order number	Designation <sup>1)</sup>	Tube	Length	Rubber	Thread	Weight	
		ØD	mm	ØD <sub>1</sub>	ØD <sub>2</sub>	g	lb
734-180-K	HOSE,CR 15 DN 3x 180,M8x1	4	180	8,8	M8x1	36	0,08
734-220-K	HOSE,CR 15 DN 3x 220,M8x1	4	220	8,8	M8x1	41	0,09
734-260-K	HOSE,CR 15 DN 3x 260,M8x1	4	260	8,8	M8x1	44	0,10
734-300-K	HOSE,CR 15 DN 3x 300,M8x1	4	300	8,8	M8x1	46	0,10
734-380-K	HOSE,CR 15 DN 3x 380,M8x1	4	380	8,8	M8x1	51	0,11
734-420-K	HOSE,CR 15 DN 3x 420,M8x1	4	420	8,8	M8x1	53	0,12
734-450-K	HOSE,CR 15 DN 3x 450,M8x1	4	450	8,8	M8x1	56	0,12
734-500-K	HOSE,CR 15 DN 3x 500,M8x1	4	500	8,8	M8x1	60	0,13
734-580-K	HOSE,CR 15 DN 3x 580,M8x1	4	580	8,8	M8x1	68	0,15

<sup>1)</sup> Material hose: mineral oil resistant CR rubber inside; 2 layers of braided rayon, outside rubber conditionally oil resistant, resistant to light cracks and ozone.  
Material metal braid: galvanized steel wire; tube ends: galvanized steel pipe.

## Tubes and hoses

Low-pressure hoses for secondary lines max. 15 bar with pipe stud on both ends and claw groove for quick connectors

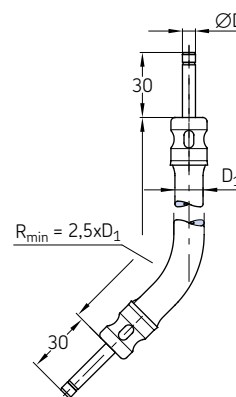

Order number	Designation <sup>1)</sup>	Tube ØD	Length	Rubber ØD <sub>1</sub>	Weight	
		mm	mm	mm	g	lb
734-180-VS	HOSE,CR 15 DN 3x 180,VS	4	180	8,8	30	0.07
734-220-VS	HOSE,CR 15 DN 3x 220,VS	4	220	8,8	33	0.07
734-260-VS	HOSE,CR 15 DN 3x 260,VS	4	260	8,8	37	0.08
734-300-VS	HOSE,CR 15 DN 3x 300,VS	4	300	8,8	40	0.09
734-380-VS	HOSE,CR 15 DN 3x 380,VS	4	380	8,8	45	0.10
734-420-VS	HOSE,CR 15 DN 3x 420,VS	4	420	8,8	47	0.10
734-450-VS	HOSE,CR 15 DN 3x 450,VS	4	450	8,8	48	0.11
734-500-VS	HOSE,CR 15 DN 3x 500,VS	4	500	8,8	58	0.13
734-580-VS	HOSE,CR 15 DN 3x 580,VS	4	580	8,8	61	0.13

<sup>1)</sup> Material hose: mineral oil resistant CR rubber inside; 2 layers of braided rayon, outside rubber conditionally oil resistant, resistant to light cracks and ozone.  
Material metal braid: galvanized steel wire; tube ends: galvanized steel pipe.

## Tubes and hoses

# Low-pressure hoses suitable for self-installation max. 45 bar

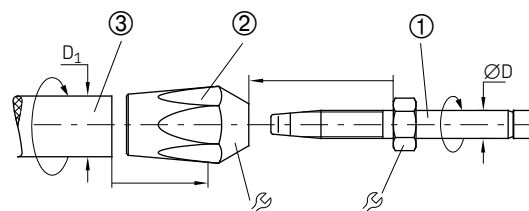

Order number	Designation	Tube ØD	D <sub>1</sub>	⌀	Material	Max. increase in volume ~ 40 bar	Weight	
		mm	mm	mm		cm <sup>3</sup> /m	g	lb
<b>① Hose coupling</b>								
406-704-001	HOSE COUPLING STRAIGHT D4 BEL	-	-	8	Steel, galvanized	1	7	0.01
406-706-001	HOSE COUPLING STRAIGHT D6 BEL	-	-	10	Steel, galvanized	1,4	11	0.02
406-708-001	HOSE COUPLING STRAIGHT D8 BEL	-	-	13	Steel, galvanized	1,4	21	0.04
406-704-001-VS	<sup>1)</sup> HOSE COUPLING STRAIGHT D4 VS	-	-	8	Steel, galvanized	1	7	0.01
406-706-001-VS	<sup>1)</sup> HOSE COUPLING STRAIGHT D6 VS	-	-	10	Steel, galvanized	1,4	11	0.02
406-708-001-VS	<sup>1)</sup> HOSE COUPLING STRAIGHT D8 VS	-	-	13	Steel, galvanized	1,4	21	0.04
<b>② Threaded sleeve</b>								
406-804-001	THREADED SLEEVE F.HOSE STUD D4	-	-	14	Brass	1	20	0.04
406-806-001	THREADED SLEEVE F.HOSE STUD D6	-	-	17	Brass	1,4	31	0.07
406-808-001	THREADED SLEEVE F.HOSE STUD D8	-	-	19	Brass	1,4	36	0.08
<b>③ Hose</b>								
WVN701-4	<sup>2)</sup> HOSE, CR 45 DN 3	4	11	-	Perbunan, braided rayon	1	117	0.26
WVN701-6	<sup>2)</sup> HOSE, CR 45 DN 4,5	6	13	-	Perbunan, braided rayon	1,4	153	0.34
WVN701-8	<sup>2)</sup> HOSE, CR 45 DN 6,5	8	15	-	Perbunan, braided rayon	1,4	190	0.42
<sup>1)</sup> VS = version with claw groove on tube ends for quick connectors <sup>2)</sup> Please quote length when ordering. Max. length available 20 m <sup>3)</sup> Perbunan, resistant to mineral oils, with two layers of braided rayon								
Permissible operating pressure: -40 to +100 °C / -40 to +212 °F								

### Low-pressure hose assignment guide (products in one and the same line below are combinable)

Hose coupling	Coupling type	ØD	Threaded sleeve	High-pressure hose	Operating pressure	
					bar	psi
mm						
406-704-001	straight	4	406-804-001	WVN701-4	45	653
406-704-001-VS	straight	4	406-804-001	WVN701-4	45	653
406-706-001	straight	6	406-806-001	WVN701-6	45	653
406-706-001-VS	straight	6	406-806-001	WVN701-6	45	653
406-708-001	straight	8	406-808-001	WVN701-8	45	653
406-708-001-VS	straight	8	406-808-001	WVN701-8	45	653

### ! Important note

To avoid damage, screw all parts only up to the stop. Do not tighten!

### Installation notes

- 1 Apply thin film of oil to inner hose end, inner threaded sleeve and outer hose coupling end.
- 2 Screw threaded sleeve onto hose end up to the stop.
- 3 Clamp threaded sleeve in vise and screw in hose coupling turning it to the left up to the stop.

## Tubes and hoses

# High-pressure hoses for self-installation

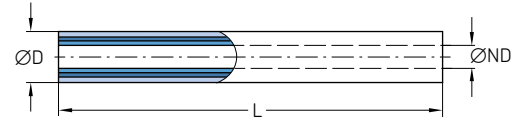

Order number <sup>1)</sup>	Designation	Tube ØD	Nominal diameter ND	Length m	Material hose	Burst pressure		Weight	
						bar	psi	g	lb
<b>111-35114-1</b>	HOSE PL300 NW4,0 HIGHFLEXIBLE	8,6	4	1	Polyamide, polyurethane <sup>2)</sup>	840	12 183	48	0.106
<b>1110-00000002</b>	HP HOSE 8,6/4,1-PA6/PUR-BK COIL50M	8,6	4	50	Polyamide, polyurethane <sup>2)</sup>	840	12 183	2 400	5.291
<b>982-750-111</b>	HOSE, PL400 NW6,0 HIGHFLEXIBLE	11,2	6	1	Polyamide, polyurethane <sup>2)</sup>	840	12 183	70	0.154
<b>1110-00000001</b>	HP HOSE 11,3/6,4-PA6/PUR-BK COIL50M	11,2	6	50	Polyamide, polyurethane <sup>2)</sup>	840	12 183	3 500	7.716
<b>WVN711-10</b>	HOSE, 3TE,NW8,0 HIGHFLEXIBLE	16,5	8	1	Synthetic rubber <sup>2)</sup>	520	7 542	198	0.432

<sup>1)</sup> Hoses can be delivered prefilled with lubricant on request.  
<sup>2)</sup> Inner hose = polyamide, soft; pressure reinforcement = polyamide high strength; sheathing = polyurethane

### Scheme - High-pressure hose self-mounting components

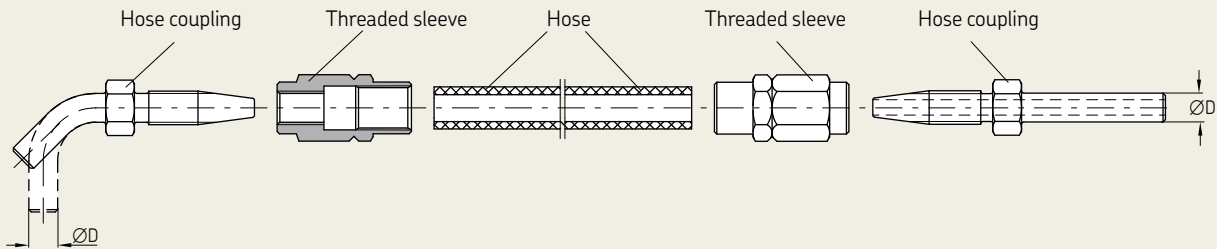

### High-pressure hoses and threaded joints assignment guide (products in one and the same line below are combinable)

Hose coupling <sup>1)</sup>	Coupling type	ØD mm	Threaded sleeve	High-pressure hose	Burst pressure	
					bar	psi
<b>853-380-006-VS</b>	straight	4	<b>853-540-010</b>	<b>111-35114-1</b>	840	12 183
<b>853-370-002(-VS)</b>	straight	6	<b>853-540-010</b>	<b>111-35114-1</b>	840	12 183
<b>853-380-002(-VS)</b>	straight	6	<b>853-540-010</b>	<b>111-35114-1</b>	840	12 183
<b>853-390-002(-VS)</b>	straight	6	<b>853-540-010</b>	<b>111-35114-1</b>	840	12 183
<b>853-380-003(-VS)</b>	90°	6	<b>853-540-010</b>	<b>111-35114-1</b>	840	12 183
<b>853-390-003(-VS)</b>	90°	6	<b>853-540-010</b>	<b>111-35114-1</b>	840	12 183
<b>853-380-004(-VS)</b>	45°	6	<b>853-540-010</b>	<b>111-35114-1</b>	840	12 183
<b>853-380-005-VS</b>	straight	6	<b>853-540-010</b>	<b>111-35114-1</b>	840	12 183
<b>853-390-005</b>	straight	6	<b>853-540-010</b>	<b>111-35114-1</b>	840	12 183
<b>853-380-007-VS</b>	45°	6	<b>853-540-010</b>	<b>111-35114-1</b>	840	12 183
<b>456-706-001</b>	straight	6	<b>853-540-010</b>	<b>111-35114-1</b>	840	12 183
<b>855-380-002</b>	straight	6	<b>853-540-010</b>	<b>111-35114-1</b>	840	12 183
<b>406-708-005(-VS)</b>	straight	8	<b>406-808-005</b>	<b>982-750-111</b>	840	12 183
<b>406-710-002</b>	straight	10	<b>406-810-002</b>	<b>WVN711-10</b>	520	7 542

<sup>1)</sup> 000-000-000(-VS) means both versions 000-000-000 and 000-000-000-VS.  
 To identify hose coupling design details, please see table on page 113.

**! Important note**  
 To avoid damage, screw all parts only up to the stop. Do not tighten!

### Installation notes

- 1 Apply thin film of oil to inner hose end, inner threaded sleeve and outer hose coupling end.
- 2 Screw threaded sleeve onto hose end up to the stop.
- 3 Clamp threaded sleeve in vise and screw in hose coupling turning it to the left up to the stop.



# Threaded joints for high-pressure hoses

Threaded sleeve

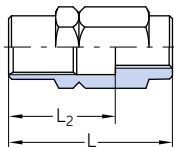

Hose coupling straight

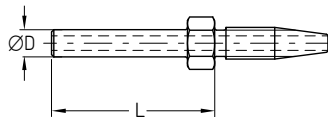

Hose coupling bent

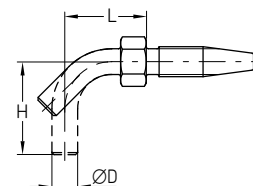

Order number	Designation	ØD	L	L <sub>2</sub>	H	Material	Weight	
							mm	mm
<b>Threaded sleeves</b>								
853-540-010	THREADED SLEEVE F.HOSE STUD D 6	6	28	17	17	Zinc-nickel, Cr-6-free	12	0.26
432-23031-1	THREADED SLEEVE F.HOSE STUD D 6	6	28	19	-	Zinc-nickel, Cr-6-free	19	0.04
406-808-005	THREADED SLEEVE F.HOSE STUD D 8	8	35	23	23	Zinc-nickel, Cr-6-free	34	0.07
406-810-002	THREADED SLEEVE F.HOSE STUD D10	10	41	32	32	Zinc-nickel, Cr-6-free	47	0.10
432-23676-1	THREADED SLEEVE F.HOSE STUD D6 VA	6	28	17	17	Stainless steel 1.4305	12	0.26
406-808-005-S3	THREADED SLEEVE F.HOSE STUD D 8 VA	8	35	23	23	Stainless steel 1.4571	34	0.07
<b>Hose studs with claw grooves for quick connectors</b>								
853-380-006-VS	HOSE STUD STRAIGHT D4/NW2 VS	4	39	-	-	Zinc-nickel, Cr-6-free	12	0.26
853-370-002-VS	HOSE STUD STRAIGHT D6/NW4 VS	6	32	-	-	Zinc-nickel, Cr-6-free	12	0.26
853-380-002-VS	HOSE STUD STRAIGHT D6/NW4 VS	6	39	-	-	Zinc-nickel, Cr-6-free	12	0.26
853-380-005-VS	HOSE STUD STRAIGHT D6/NW4 VS	6	49	-	-	Zinc-nickel, Cr-6-free	14	0.03
853-390-002-VS	HOSE STUD 45DEGREE D6/NW4 VS	6	75	-	-	Zinc-nickel, Cr-6-free	18	0.03
853-390-006-VS	HOSE STUD 10DEGREE D6/NW4 VS	6	70	-	10	Zinc-nickel, Cr-6-free	18	0.03
853-390-005-VS	HOSE STUD 30DEGREE D6/NW4 VS	6	70	-	17	Zinc-nickel, Cr-6-free	19	0.04
853-380-004-VS	HOSE STUD 45DEGREE D6/NW4 VS	6	40	-	23	Zinc-nickel, Cr-6-free	14	0.03
853-380-007-VS	HOSE STUD STRAIGHT D6/NW4 VS	6	65	-	18	Zinc-nickel, Cr-6-free	19	0.04
853-390-004-VS	HOSE STUD 45DEGREE D6/NW4 VS	6	65	-	24	Zinc-nickel, Cr-6-free	19	0.04
853-380-003-VS	HOSE STUD 90DEGREE D6/NW4 VS	6	19	-	35	Zinc-nickel, Cr-6-free	14	0.03
853-390-003-VS	HOSE STUD 90DEGREE D6/NW4 VS	6	30	-	50	Zinc-nickel, Cr-6-free	19	0.04
406-708-005-VS	HOSE STUD STRAIGHT D8/NW6 VS	8	39	-	-	Zinc-nickel, Cr-6-free	21	0.05
855-380-002-VS	HOSE STUD VA STRAIGHT D6/NW4 VS	6	39	-	-	Stainless steel 1.4305	12	0.26
855-380-003-VS	HOSE STUD VA 90DEGREE D6/NW4 VS	6	19	-	35	Stainless steel 1.4305	13	0.03
<b>Hose studs</b>								
432-24162-1	HOSE STUD D6/NW 4 SHORT	6	25	-	-	Zinc-nickel, Cr-6-free	10	0.02
532-30739-1	HOSE STUD 90DEGREE SHORT	6	29,5	-	-	Zinc-nickel, Cr-6-free	12	0.02
853-370-002	HOSE STUD STRAIGHT D6/NW4 BEL	6	26	-	-	Zinc-nickel, Cr-6-free	10	0.02
853-380-002	HOSE STUD STRAIGHT D6/NW4 BEL	6	30	-	-	Zinc-nickel, Cr-6-free	12	0.02
853-390-002	HOSE STUD STRAIGHT D6/NW4 BEL	6	75	-	-	Zinc-nickel, Cr-6-free	20	0.04
853-390-005	HOSE STUD STRAIGHT D6/NW4 BEL	6	64	-	-	Zinc-nickel, Cr-6-free	20	0.04
853-380-004	HOSE STUD 45DEGREE D6/NW4 BEL	6	29	-	11	Zinc-nickel, Cr-6-free	20	0.04
853-380-003	HOSE STUD 90DEGREE D6/NW4 BEL	6	19	-	21	Zinc-nickel, Cr-6-free	10	0.02
853-390-003	HOSE STUD 90DEGREE D6/NW4 BEL	6	30	-	50	Zinc-nickel, Cr-6-free	20	0.04
853-390-004	HOSE STUD 90DEGREE D6/NW4 BEL	6	24	-	36	Zinc-nickel, Cr-6-free	16	0.03
406-708-005	HOSE STUD STRAIGHT D8/NW6 BEL	8	26	-	-	Zinc-nickel, Cr-6-free	19	0.04
406-708-006	HOSE STUD STRAIGHT D8/NW6 BEL	8	32	-	-	Zinc-nickel, Cr-6-free	20	0.04
406-708-007	HOSE STUD STRAIGHT D8/NW6 BEL	8	53	-	-	Zinc-nickel, Cr-6-free	24	0.05
406-708-009	HOSE STUD 45DEGREE D6/NW4 BEL	8	43	-	26	Zinc-nickel, Cr-6-free	20	0.04
406-708-008	HOSE STUD 90DEGREE D8/NW6 BEL	8	25	-	34	Zinc-nickel, Cr-6-free	20	0.04
406-710-002	HOSE STUD STRAIGHT D10/NW8 BEL	10	35	-	-	Zinc-nickel, Cr-6-free	32	0.07
855-380-002	HOSE STUD VA STRAIGHT D6/NW4 BEL	6	36	-	-	Stainless steel 1.4305	12	0.02
855-380-003	HOSE STUD VA 90DEGREE D6/NW4 BEL	6	19	-	21	Stainless steel 1.4305	13	0.02
406-708-005-S3	HOSE STUD STRAIGHT D8/NW6 BEL	8	22	-	-	Stainless steel 1.4571	20	0.04

## Tubes and hoses

# Plastic tube T

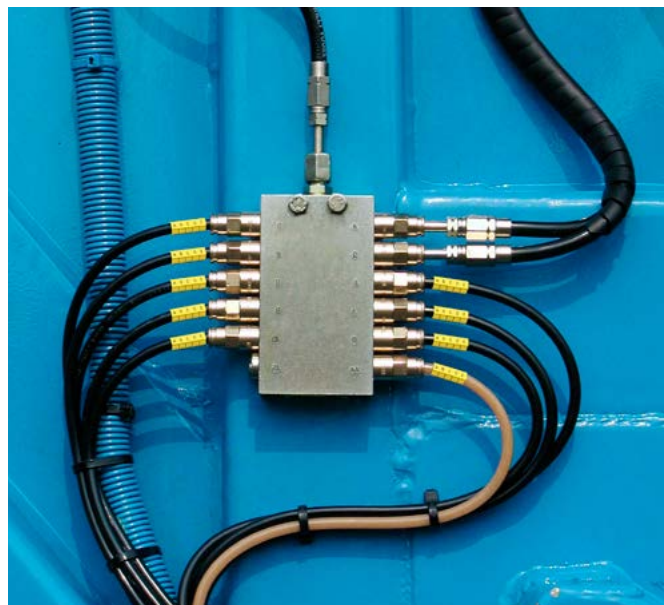

### Description

Tailored SKF plastic tubes are configurable tubes in custom lengths optionally available prefilled with standard greases for quick and easy mounting. They come in nominal diameters from 2 to 10 mm and optionally also with hose protection and customer-specific markings as hose label, printing or with clips. Configuration takes place via SKF online tube configurator or via SKF parts library app.

### Features and benefits

- Custom tube lengths for quick and easy installation
- Easy online configuration with automatically created order numbers and CAD data download
- Prefilled with SKF or special grease
- Customized tube end markings
- Optionally with tube protection
- Imprints for easy identification

### Applications

- Metal and plastic forming machinery
- Construction machinery
- Agriculture machinery
- Renewable energy
- Machine tools
- Printing
- Marine

### Technical data

Function	plastic tubes
Operating temperature	-60 to +80 °C; -76 to 175 °F
Nominal diameters	2, 4, 6, 8, 10 mm
Lengths	100–50 000 mm; 3.9–1 968 in
Lubricants	oil, fluid grease and grease up to NLGI 3
Optional markings	label, printing or clips
Materials	Polyamide PA 6.12 or Polyamide PA 12 acc. to DIN 73378
Material options	L = black, stabilized against light PH = flexible, containing plasticizer, stabilized against heat and aging H = semirigid, unplasticized, stabilized against heat and aging

### Online tube configurator

3D CAD data, technical drawings and data sheets of plastic tubes are now available in native format in the online parts library. In addition to enjoying easy CAD downloads, you can configure tubes with custom lengths and integrate them into your design process.



<https://skf-lubrication.partcommunity.com>

# High-pressure hose H



## Description

Tailored high-pressure hoses are configurable hoses in custom lengths and fittings for quick and easy mounting. They are available prefilled with standard greases and come with nominal diameters of 6, 8 and 10 mm. In case of demanding operating environments of the lubrication system consider using hose protections. To simplify installation of more complex systems with many lubrication lines SKF offers customer-specific markings, for example with a hose label, printing or with clips. Configuration of tailored hoses takes place via SKF online configurator or via SKF parts library app.

## Features and benefits

- Individual hose lengths and customized fittings for quick and easy installation
- Easy online configuration with automatically created order numbers and CAD data download
- Prefilled with standard or individual grease
- Customized hose end markings
- Imprints for easy identification
- Optional hose protection

## Applications

- Construction machinery
- Agriculture machinery
- Renewable energy
- Railways
- Marine

## Technical data

Function	high-pressure hoses
Operating temperature	ND6, ND8 = -40 to +70 °C, -40 to 158 °F ND10 = -40 to +100 °C, -40 to 212 °F
Material	polyamide (soft), polyester (high strength), polyurethane, synthetic rubber
Nominal diameter	6, 8 or 10 mm
Lengths	50–50 000 mm; 1.9–1 968 in
Lubricants	oil, fluid grease and grease up to NLGI 3
Optional markings	label, printing or clips
Operating pressure	max. 130–840 bar; 1 885–12 183 psi depending on model/size/length

## Online hose configurator

3D CAD data, technical drawings and data sheets of high-pressure hoses are now available in native format in the online parts library. In addition to enjoying easy CAD downloads, you can combine and configure hoses with the fittings of your choice and integrate them into your design process.



<https://skf-lubrication.partcommunity.com>

## Fixing material



### Description

The following chapter includes the screws and bolts for fixing the individual components of lubrication systems, as well as cable straps, mounting bases and a large selection of pipe clamps for fixing the pipes.

Clamps for pipes with a diameter of 8 mm and 10 mm are available in two versions: One according to DIN 72573 and another reinforced design version with a thicker and wider metal sheet than DIN 72573.

For use in corrosive areas, various mounting parts are also available in stainless steel (material 1.4571).

### Features and benefits

- Wide product range with many different dimensions
- Recommended and reliable fixing material for lubrication system components such as pipes and tubes
- Suitable for all types of automatic lubrication systems

### Applications

- Metal forming machines
- On- and off-road vehicles
- Construction and mining
- Agriculture machinery
- Packaging machines
- General industry
- Etc.

# Fixing material

## Fixing clips

602-001 – 612-001, 226-xxxx-1

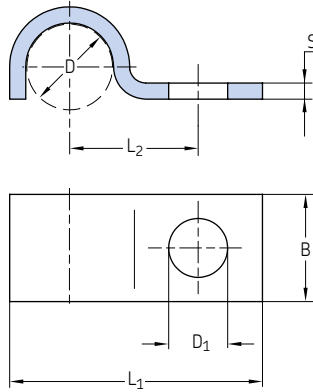

608-003

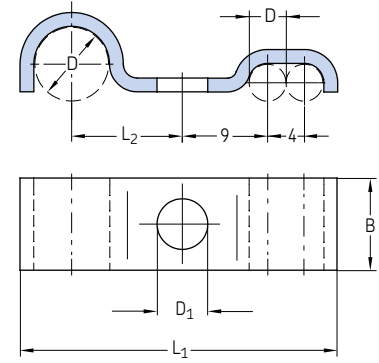

Order number	Designation	Tube ØD	B	D <sub>1</sub>	L <sub>1</sub>	L <sub>2</sub>	S	Material	Weight (100 pcs)	
									g	lb
Zinc-plated steel										
602-001	TUBE CLAMP ST-Z D 2,5(1x)	2,5 mm	10	3,5	11,25	5	1,5	Zinc-plated steel	200	0.44
604-001	TUBE CLAMP ST-Z D 4(1x)	4 mm	10	5,5	18,5	9	1,5	Zinc-plated steel	200	0.44
606-010	TUBE CLAMP ST-Z D 6(1x)	6 mm	10	5,5	20,5	10	1,5	Zinc-plated steel	300	0.66
608-001	TUBE CLAMP ST-Z D 8(1x)	8 mm	10	5,5	23,5	12	1,5	Zinc-plated steel	300	0.66
608-003	TUBE CLAMP ST-Z D 8(1x)D4(2x)	8 mm / 4 mm	10	5,5	34	12	1,5	Zinc-plated steel	300	0.66
610-001	TUBE CLAMP ST-Z D10(1x)	10 mm or 1/8	10	5,5	25,5	13	1,5	Zinc-plated steel	400	0.88
612-001	TUBE CLAMP ST-Z D12(1x)	12 mm	20	6,8	35	18	2	Zinc-plated steel	500	1.1
226-12335-7										
226-12335-7	TUBE CLAMP ST-Z D 6(1X)ZG	6 mm	10	4,8	20,5	10	1	Zinc-plated steel	200	0.44
226-12337-1	TUBE CLAMP ST-Z D 8(1X)ZG	8 mm	15	7	28	15,5	2	Zinc-plated steel	700	1.54
226-12338-1	TUBE CLAMP ST-Z D10(1X)ZG	10 mm	15	7	30	15	2	Zinc-plated steel	800	1.76
Stainless steel										
226-13716-1	TUBE CLAMP 1.4571 D 6(1X)	6 mm	10	4,8	20	10	1	Stainless steel 1.4571	200	0.44
226-13717-1	TUBE CLAMP 1.4571 D 8(1X)	8 mm	15	7	28	15,5	2	Stainless steel 1.4571	700	1.54
226-13673-1	TUBE CLAMP 1.4571 D10(1X)	10 mm	15	7	30	15	2	Stainless steel 1.4571	800	1.76

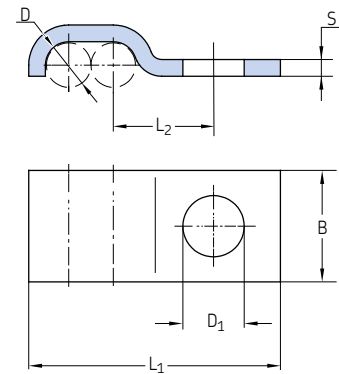

Order number	Designation	Tube ØD	Number of tubes	B	D <sub>1</sub>	L <sub>1</sub>	L <sub>2</sub>	S	Material	Weight (100 pcs)	
										g	lb
602-002	TUBE CLAMP ST-Z D 2,5(2x)	2,5	2	10	3,5	13,8	5	1,5	Zinc-plated steel	200	0.44
604-002	TUBE CLAMP ST-Z D 4(2x)	4	2	10	5,5	22,6	9	1,5	Zinc-plated steel	200	0.44
604-003	TUBE CLAMP ST-Z D 4(3x)	4	3	10	5,5	26,6	9	1,5	Zinc-plated steel	300	0.66

## Fixing clips

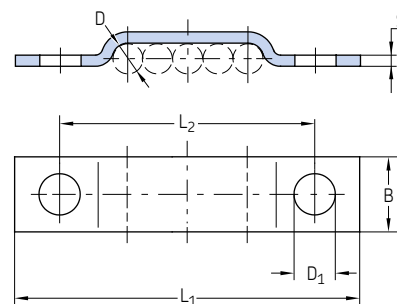

Order number	Designation	Tube ØD	Number of tubes	B	D <sub>1</sub>	L <sub>1</sub>	L <sub>2</sub>	S	Material	Weight (100 pcs)	
		mm	mm	mm	mm	mm	mm	mm		g	lb
<b>Zinc-plated steel</b>											
604-014	TUBE CLAMP ST-Z D 4(4x)	4	4	10	5,5	42	30	1,5	Zinc-plated steel	400	0,88
604-015	TUBE CLAMP ST-Z D 4(5x)	4	5	10	5,5	46	34	1,5	Zinc-plated steel	400	0,88
604-016	TUBE CLAMP ST-Z D 4(6x)	4	6	10	5,5	50	38	1,5	Zinc-plated steel	500	1,1
604-018	TUBE CLAMP ST-Z D 4(8x)	4	8	10	5,5	58	46	1,5	Zinc-plated steel	600	1,32
DIN72573-2x6-ST	TUBE CLAMP ST-Z D 6(2x)	6	2	10	4,8	39	27	1	Zinc-plated steel	300	0,66
DIN72573-3x6-ST	TUBE CLAMP ST-Z D 6(3x)	6	3	10	4,8	45	33	1	Zinc-plated steel	400	0,88
DIN72573-4x6-ST	TUBE CLAMP ST-Z D 6(4x)	6	4	10	4,8	51	39	1	Zinc-plated steel	400	0,88
DIN72573-5x6-ST	TUBE CLAMP ST-Z D 6(5x)	6	5	10	4,8	57	45	1	Zinc-plated steel	400	0,88
DIN72573-6x6-ST	TUBE CLAMP ST-Z D 6(6x)	6	6	10	4,8	64	52	1	Zinc-plated steel	600	1,32
DIN72573-2x8-ST	TUBE CLAMP ST-Z D 8(2x)	8	2	10	4,8	43	31	1	Zinc-plated steel	400	0,88
DIN72573-3x8-ST	TUBE CLAMP ST-Z D 8(3x)	8	3	10	4,8	51	39	1	Zinc-plated steel	400	0,88
DIN72573-4x8-ST	TUBE CLAMP ST-Z D 8(4x)	8	4	10	4,8	59	47	1	Zinc-plated steel	500	1,1
DIN72573-5x8-ST	TUBE CLAMP ST-Z D 8(5x)	8	5	10	4,8	68	56	1	Zinc-plated steel	600	1,32
D72573-6x8ST+ZZ1	TUBE CLAMP ST-Z D 8(6x)	8	6	10	4,8	75	56	1	Zinc-plated steel	700	1,54
DIN72573-2x10-ST	TUBE CLAMP ST-Z D10(2x)	10	2	10	4,8	45	33	1	Zinc-plated steel	400	0,88
DIN72573-3x10-ST	TUBE CLAMP ST-Z D10(3x)	10	3	10	4,8	55	43	1	Zinc-plated steel	500	1,1
DIN72573-4x10-ST	TUBE CLAMP ST-Z D10(4x)	10	4	10	4,8	67	55	1	Zinc-plated steel	600	1,32
DIN72573-5x10-ST	TUBE CLAMP ST-Z D10(5x)	10	5	10	4,8	77	65	1	Zinc-plated steel	800	1,76
<b>Zinc-plated steel</b>											
226-12337-2	TUBE CLAMP ST-Z D 8(2X)	8	2	15	7	61,2	39	2	Zinc-plated steel	1 300	2,87
226-12337-3	TUBE CLAMP ST-Z D 8(3X)	8	3	15	7	69,2	47	2	Zinc-plated steel	1 500	3,31
226-12337-4	TUBE CLAMP ST-Z D 8(4X)	8	4	15	7	77,2	55	2	Zinc-plated steel	1 700	3,75
226-12337-5	TUBE CLAMP ST-Z D 8(5X)	8	5	15	7	85,2	63	2	Zinc-plated steel	1 800	3,97
226-12337-6	TUBE CLAMP ST-Z D 8(6X)	8	6	15	7	93,2	71	2	Zinc-plated steel	2 000	4,41
226-12338-2	TUBE CLAMP ST-Z D10(2X)	10	2	15	7	65,3	40	2	Zinc-plated steel	1 300	2,87
226-12338-3	TUBE CLAMP ST-Z D10(3X)	10	3	15	7	75,3	50	2	Zinc-plated steel	1 600	3,53
226-12338-4	TUBE CLAMP ST-Z D10(4X)	10	4	15	7	85,3	60	2	Zinc-plated steel	1 800	3,97
226-12338-5	TUBE CLAMP ST-Z D10(5X)	10	5	15	7	95,3	70	2	Zinc-plated steel	2 000	4,41
226-12338-6	TUBE CLAMP ST-Z D10(6X)	10	6	15	7	105,3	80	2	Zinc-plated steel	2 200	4,85
<b>Stainless steel</b>											
226-13716-2	TUBE CLAMP 1.4571 D 6(2x)	6	2	10	4,8	38	26	1	Stainless steel 1.4571	340	0,75
226-13716-3	TUBE CLAMP 1.4571 D 6(3x)	6	3	10	4,8	45	33	1	Stainless steel 1.4571	410	0,90
226-13716-4	TUBE CLAMP 1.4571 D 6(4x)	6	4	10	4,8	51	39	1	Stainless steel 1.4571	450	0,99
226-13716-5	TUBE CLAMP 1.4571 D 6(5x)	6	5	10	4,8	57	45	1	Stainless steel 1.4571	470	1,04
226-13673-6	TUBE CLAMP 1.4571 D 6(6x)	6	6	10	4,8	64	52	1	Stainless steel 1.4571	500	1,10
<b>Stainless steel</b>											
226-13717-2	TUBE CLAMP 1.4571 D 8(2x)	8	2	15	7	61,2	39	2	Stainless steel 1.4571	1 200	2,65
226-13717-3	TUBE CLAMP 1.4571 D 8(3X)	8	3	15	7	69,2	47	2	Stainless steel 1.4571	1 400	3,09
226-13717-4	TUBE CLAMP 1.4571 D 8(4X)	8	4	15	7	77,2	55	2	Stainless steel 1.4571	1 600	3,53
226-13718-1	TUBE CLAMP 1.4571 D10(2X)	10	2	15	7	65,3	40	2	Stainless steel 1.4571	1 300	2,87
226-13673-4	TUBE CLAMP 1.4571 D10(3X)	10	3	15	7	75,3	50	2	Stainless steel 1.4571	1 600	3,53
226-13673-5	TUBE CLAMP 1.4571 D10(4X)	10	4	15	7	85,3	60	2	Stainless steel 1.4571	1 700	3,75
226-13718-2	TUBE CLAMP 1.4571 D10(5X)	10	5	15	7	95	70	2	Stainless steel 1.4571	2 100	4,63
226-13718-3	TUBE CLAMP 1.4571 D10(6X)	10	6	15	7	105	80	2	Stainless steel 1.4571	2 300	5,07

## Fixing material

### Fixing clips

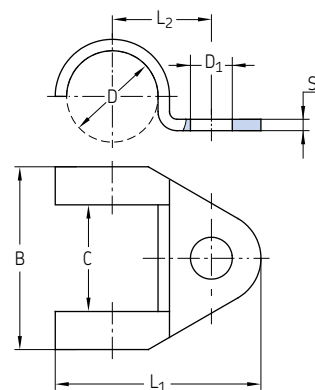

Fixing material

Order number	Designation	Tube $\varnothing D$		B	C	$D_1$	$L_1$	$L_2$	S	Material	Weight (100 pcs)	
		mm	in								g	lb
604-004	TUBE CLAMP ST-Z D12(1x)	12	-	24	14	5,5	27	13	1,5	Zinc-plated steel	500	1.1
606-014	TUBE CLAMP ST-Z D14(1x)	14	1/4	30	15	6,3	34	16	2	Zinc-plated steel	1 200	2.65
608-004	TUBE CLAMP ST-Z D18(1x)	18	3/8	36	20	7	40	21	1,5	Zinc-plated steel	1 200	2.65
610-004	TUBE CLAMP ST-Z D20(1x)	20	1/2	36	20	7	40	21	1,5	Zinc-plated steel	1 200	2.65

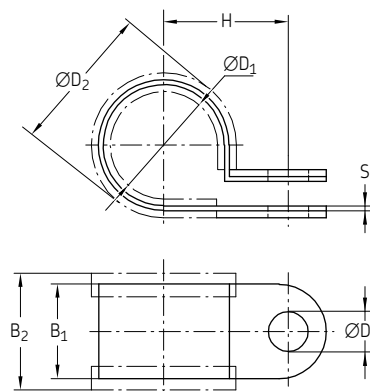

Order number	Designation	$\varnothing D_1$	$\varnothing D_2$	$\varnothing D_3$	$B_1$	$B_2$	H	S	Material	Weight (100 pcs)	
										mm	mm
941-206-104	TUBE CLAMP ST-RUB. D 6 F.FAST.SCREW M5	6	11,8	5,2	12	15	11	0,5	Steel, galvanized	400	0.88
941-206-108	TUBE CLAMP ST-RUB. D 6 F.FAST.SCREW M6	6	11,8	6,4	15	18,5	4,2	0,6	Steel, galvanized	700	1.54
941-208-104	TUBE CLAMP ST-RUB. D 8 F.FAST.SCREW M6	8	15,4	6,4	15	18,5	15,2	0,6	Steel, galvanized	800	1.76
941-209-104	TUBE CLAMP ST-RUB. D 9 F.FAST.SCREW M5	9	5	5,2	12	5	12,5	0,5	Steel, galvanized	500	1.1
941-209-105	TUBE CLAMP ST-RUB. D 9 F.FAST.SCREW M6	9	15	6,4	15	18,5	15,7	0,6	Steel, galvanized	900	1.98
941-210-104	TUBE CLAMP ST-RUB. D10 F.FAST.SCREW M6	10	17,4	6,4	15	18,5	16,2	0,6	Steel, galvanized	900	1.98
941-212-104	TUBE CLAMP ST-RUB. D12 F.FAST.SCREW M6	12	19,4	6,4	15	18,5	17,2	0,6	Steel, galvanized	1 000	2.21
941-213-104	TUBE CLAMP ST-RUB. D13 F.FAST.SCREW M6	13	20,4	6,4	15	18,5	7,7	0,6	Steel, galvanized	1 100	2.43
941-215-104	TUBE CLAMP ST-RUB. D15 F.FAST.SCREW M6	15	22,4	6,4	5	18,5	18,7	0,8	Steel, galvanized	2 000	4.41
941-217-104	TUBE CLAMP ST-RUB. D17 F.FAST.SCREW M5	17	23	5,2	12	15	16,5	0,5	Steel, galvanized	800	1.76
941-217-105	TUBE CLAMP ST-RUB. D17 F.FAST.SCREW M6	17	23	6,4	15	8,5	19,7	0,8	Steel, galvanized	1 500	3.31
941-218-101	TUBE CLAMP ST-RUB. D18 F.FAST.SCREW M6	18	24	6,4	15	8,5	20,2	0,6	Steel, galvanized	1 400	3.09
941-220-104	TUBE CLAMP ST-RUB. D20 F.FAST.SCREW M6	20	27,6	6,4	15	8,5	21,2	0,8	Steel, galvanized	1 500	3.31
941-222-100	TUBE CLAMP ST-RUB. D22 F.FAST.SCREW M6	22	28	6,4	15	18,5	22,2	0,8	Steel, galvanized	1 700	3.75
941-225-104	TUBE CLAMP ST-RUB. D25 F.FAST.SCREW M6	25	31	6,4	15	18,5	23,7	0,8	Steel, galvanized	2 000	4.41

## Fixing material

# Pipe brackets acc. to DIN 3015

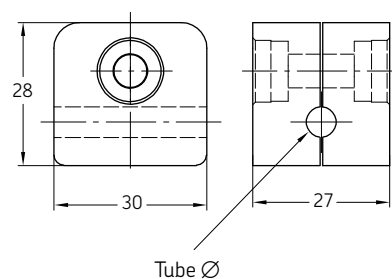

Order number	Designation	Tube Ø	Material	Weight	
				g	lb
		mm			
<b>941-606-000</b>	TUBE CLAMP 106 PP	6	Polypropylene	10	0.02
<b>941-608-000</b>	TUBE CLAMP 108 PP	8	Polypropylene	10	0.02
<b>941-610-000</b>	TUBE CLAMP 110 PP	10	Polypropylene	5	0.01
Tube clamp PP with weld plate, standard series					
<b>226-12343-5</b>	TUBE CLAMP SP 110 PP -LI	10	Polypropylene	40	0.09
<b>226-12343-1</b>	TUBE CLAMP SP 320 PP -LI	20	Polypropylene	77	0.17
<b>226-13097-3</b>	TUBE CLAMP SP 320 /20 PP -GD -AS	2x20	Polypropylene	173	0.38
<b>226-12343-2</b>	TUBE CLAMP SP 430 PP -LI	30	Polypropylene	80	0.18
Tube clamp PP with weld plate and cover plate, heavy series					
<b>226-13058-3</b>	TUBE CLAMP SPAL4020 PP -DPAL-AS	20	Polypropylene	394	0.87
<b>226-13058-5</b>	TUBE CLAMP SPAL5030 PP -DPAL-AS	30	Polypropylene	480	1.06

## Cable straps

898-610-000, 898-710-000, 898-710-001

898-510-000

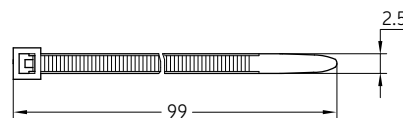
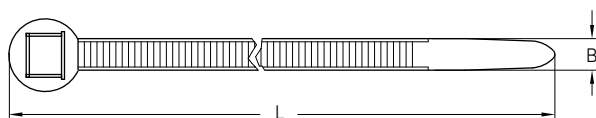

Order number	Designation	L	B	Material	Weight (100 pcs)	
					g	lb
		mm	mm			
<b>898-610-000</b>	CABLE STRAP SW 204LGx4,7	197	4,9	Polyamide	100	0.22
<b>898-710-000</b>	CABLE STRAP SW 302LGx4,8	302	4,9	Polyamide	200	0.44
<b>898-710-001</b>	CABLE STRAP SW 360LGx7,5	360	7,5	Polyamide	500	1.10
For automatic pincers						
<b>898-510-000</b>	CABLE STRAP SW 100LGx2,5	99	2,5	Polyamide	100	0.22



## Fixing material

# Mounting base

Order number	Designation	Material	Weight (100 pcs)	
			g	lb
179-990-186	MOUNTING PLATE 25,4x25,4	ABS	100	0.22

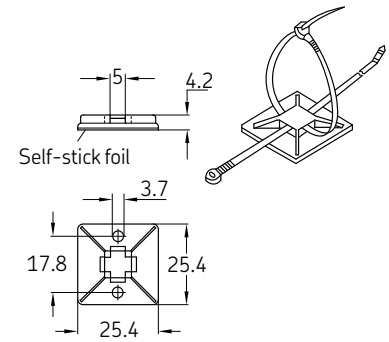

# Fixing bolts

DIN EN ISO 4762

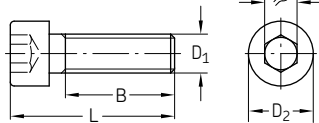

IN EN ISO 4014 / DIN EN ISO 4017

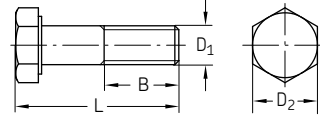

DIN7513

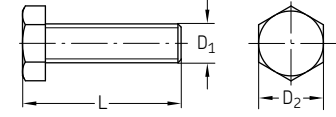

Order number	Designation	D <sub>1</sub>	L	D <sub>2</sub>	B	⌀	Material	Weight	
								g	lb
Steel, galvanized									
201-12015-5	SCREW,SOCK,HEX. 8.8 M4x 20CF	M4	20	7	14	3	Steel, galvanized	3	0.007
201-12019-9	SCREW,SOCK,HEX. 8.8 M6x 16CF	M6	16	10	18	5	Steel, galvanized	6	0.013
201-12018-7	SCREW,SOCK,HEX. 8.8 M6x 25CF	M6	25	10	18	5	Steel, galvanized	7	0.015
201-12019-6	SCREW,SOCK,HEX. 8.8 M6x 60CF	M6	60	10	18	5	Steel, galvanized	14	0.031
201-12021-3	SCREW,SOCK,HEX. 8.8 M8x 16CF	M8	16	13	12	6	Steel, galvanized	20	0.044
DIN931-M6x30-8.8	SCREW,HEX. 8.8 M 6x 30 CF	M6	30	10	18	10	Steel, galvanized	8	0.018
DIN933-M4x10-8.8	SCREW,HEX. 8.8 M 4x 10 CF	M4	10	7	5	-	Steel, galvanized	2	0.004
200-13092-1	SCREW,HEX. 8.8 M 5x 12CF	M5	12	8	6	-	Steel, galvanized	3	0.007
200-13017-9	SCREW,HEX. 8.8 M 5x 16CF	M5	16	8	11	-	Steel, galvanized	3	0.007
200-13017-5	SCREW,HEX. 8.8 M 5x 45CF	M5	45	8	40	-	Steel, galvanized	7	0.015
200-13022-4	SCREW,HEX. 8.8 M 6x 16CF	M6	16	10	9	-	Steel, galvanized	5	0.011
200-13022-7	SCREW,HEX. 8.8 M 6x 20CF	M6	20	10	13	-	Steel, galvanized	6	0.013
200-13022-1	SCREW,HEX. 8.8 M 6x 25CF	M6	25	10	19	-	Steel, galvanized	7	0.015
200-13037-3	SCREW,HEX. 8.8 M 6x 60CF	M6	60	10	53	-	Steel, galvanized	14	0.031
200-12553-4	SCREW,HEX. 8.8 M 8x 20CF	M8	20	13	11	-	Steel, galvanized	12	0.026
200-10406-7	SCREW,HEX. 8.8 M 8x 25CF	M8	25	13	16	-	Steel, galvanized	13	0.029
200-12007-6	SCREW,HEX. 8.8 M 8x 30CF	M8	30	13	21	-	Steel, galvanized	15	0.033
200-12553-8	SCREW,HEX. 8.8 M 8x 40CF	M8	40	13	31	-	Steel, galvanized	18	0.04
200-12399-2	SCREW,HEX. 8.8 M 8x 80CF	M8	80	13	71	-	Steel, galvanized	34	0.075
200-12523-3	SCREW,HEX. 8.8 M10x 40CF	M10	40	16	39	-	Steel, galvanized	30	0.066
200-12009-7	SCREW,HEX. 8.8 M12x 40CF	M12	40	18	28	-	Steel, galvanized	34	0.075
DIN7513-BM4x20	SCREW,SELF-TAPP C15 BM 4,0x 20 CF	M4	20	7	-	-	Steel, galvanized	2	0.004
DIN7513-BM4x25	SCREW,SELF-TAPP C15 BM 4,0x 25 CF	M4	25	7	-	-	Steel, galvanized	2	0.004
206-12124-3	SCREW,SELF-TAPP C15 BM 5,0x 10	M5	10	8,5	-	-	Steel	2	0.004
DIN7513-BM6x25	SCREW,SELF-TAPP C15 BM 6,0x 25 CF	M6	25	10	-	-	Steel, galvanized	6	0.013
Stainless steel									
DIN912-M3x8-A4	SCREW,SOCK,HEX. A4 M 3x 8	M3	8	5,5	-	-	Stainless steel 1.4404	1	0.002
201-13741-1	SCREW,SOCK,HEX. A4 M 4x12	M4	12	7	-	-	Stainless steel 1.4571	2	0.004
201-13608-6	SCREW,SOCK,HEX. A2 M 5x10	M5	10	7	-	-	Stainless steel 1.4571	2	0.004

## Couplings



### Description

Couplings for hydraulic or lubrication systems are required whenever a virtually leakage-free flow of media is to be separated or distributed. Typically, this happens e.g. when a pump is used to fill several lubricant reservoirs and must be connected and disconnected again and again.

For each coupling design/model, a corresponding hose is required. Conveniently, the coupling side is on the hose of the filling pump and the counterpart, the coupling nipple, is attached to the reservoir. Another coupling application in the field of lubrication systems is the coupling and uncoupling of groups of machines that need not be continuously supplied by one lubrication pump, e.g. for vehicle lubrication and trailer lubrication.

When selecting a coupling, the maximum possible pump/system pressure must be considered. In addition, there are couplings suitable mainly for either indoor or outdoor applications. If the application is not accurately defined before ordering, stainless steel or surface-treated couplings are the best choice. Couplings protect hydraulic fluids or lubricants for contamination and allow quick and high-pressure media flows.

### Features and benefits

- Wide product range with different pressure rates and sizes
- Available for filling as well as for operation of automatic lubrication systems
- Quick couplings (ESK) for under-pressure coupling available
- Virtually leakage-free filling

### Applications

- All kinds of lubrication systems
- Printing and packaging machines
- Construction and mining
- Metal forming machines
- Vehicles, trucks, loaders
- Agriculture machinery
- General industry
- Machine tools
- Etc.

## Couplings

## Low-pressure quick-disconnect couplings

Coupling, complete

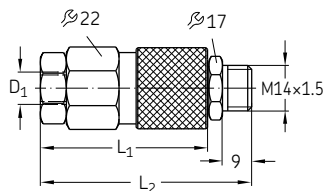

Outer coupling member

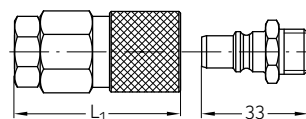

Inner coupling member

Order number	Designation	Tube $\varnothing$ D <sub>1</sub> <sup>1)</sup>		L <sub>1</sub>	L <sub>2</sub>	Material	Operating pressure max.		Weight	
		mm	mm				bar	psi	g	lb
<b>207-168-2</b>	COUPLING, COMPLETE	6	M10x1	–	65	Steel, galvanized	45	653	150	0.33
<b>207-188-2</b>	COUPLING, COMPLETE	8	M14x1,5	–	71,5	Steel, galvanized	45	653	152	0.34
<b>207-168.U7</b>	OUTER COUPLING MEMBER	6	–	51,5	–	Steel, galvanized	45	653	120	0.26
<b>207-188.U11</b>	OUTER COUPLING MEMBER	8	–	58	–	Steel, galvanized	45	653	130	0.29
<b>207-168.U2</b>	INNER COUPLING MEMBER	–	–	–	–	Steel, galvanized	45	653	22	0.05

Both coupling members are shut off when disconnected!

<sup>1)</sup> Ports tapped for solderless tube connection

## Medium- and high-pressure quick-disconnect couplings

995-001-525, 995-001-526

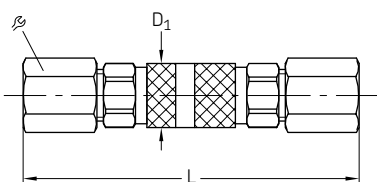

626-26246-1

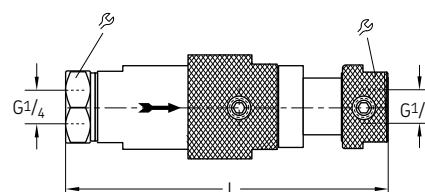

Order number	Designation	Tube $\varnothing$ D <sub>1</sub>		L	$\beta$	Material	Operating pressure max.		Weight	
		mm	mm				mm	mm	bar	psi
<b>995-001-525</b>	PLUG AND SOCKET COUPLING, TUBE 4	4	10	68	10	Steel, galvanized	100	1 450	30	0.07
<b>995-001-526</b>	PLUG AND SOCKET COUPLING, TUBE 6	6	15	80	12	Steel, galvanized	100	1 450	35	0.08
<b>626-26246-1</b>	COUPLING ESK G1/4 D	–	–	124	27	Steel, galvanized	300	4 351	760	1.68

## Couplings

## High-pressure couplings

995-001-096

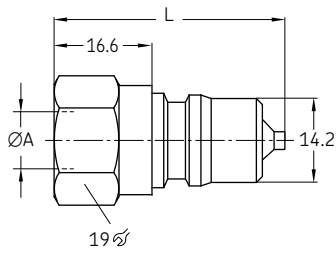

995-001-500

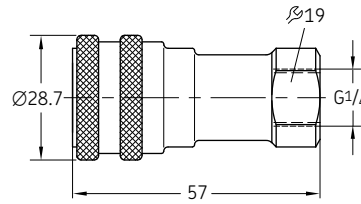

995-001-501 / 995-001-502

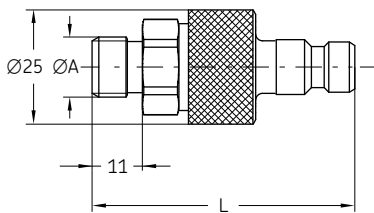

995-001-950

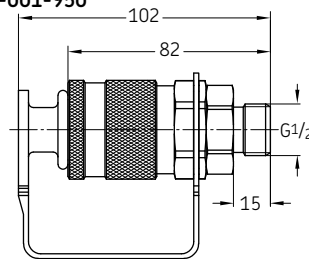

995-000-705

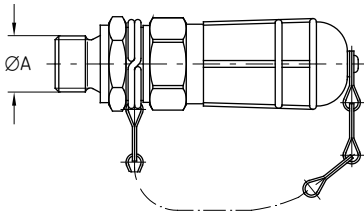

995-001-500

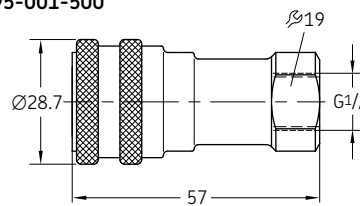

Order number	Designation	Material	ØA	L	Respective dust cover Order number	Respective coupling socket Order number	Operating pressure max.		Weight	
							bar	psi	g	lb
995-001-096	COUPLING PLUG G1/4 350BAR	Steel, galvanized	G 1/4	39	995-001-235	995-001-500	350	5 080	60 <sup>1)</sup>	0.13 <sup>1)</sup>
995-001-501	COUPLING PLUG G1/4 200BAR	Steel, galvanized	G 1/4	57.5	995-001-503	995-002-073	200	2 900	305 <sup>2)</sup>	0.67 <sup>2)</sup>
995-001-502	COUPLING PLUG G1/2 250BAR	Steel, galvanized	G 1/2	82	995-001-504	995-001-950	250	3 600	1 050 <sup>2)</sup>	2.32 <sup>2)</sup>
995-000-705	COUPLING PLUG G1/4 70BAR	Steel, galvanized	G 1/4	—	—	995-001-500	70	1 000	233 <sup>3)</sup>	0.51 <sup>3)</sup>

<sup>1)</sup> weight for plug + dust cover  
<sup>2)</sup> weight for complete coupling  
<sup>3)</sup> weight for plug + coupling socket

## Couplings

# Couplings with return flow port

995-001-620

995-001-621

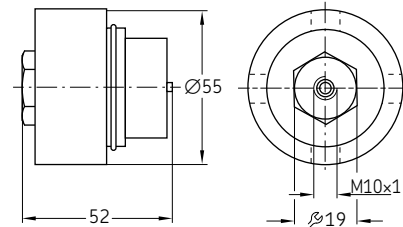
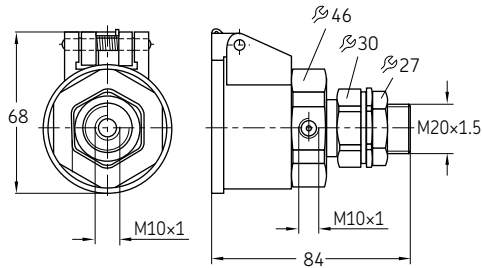

995-001-622

995-001-623

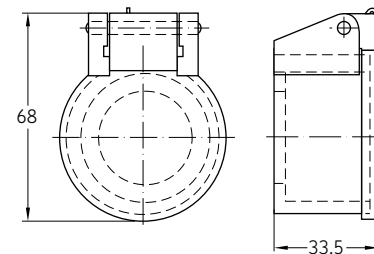
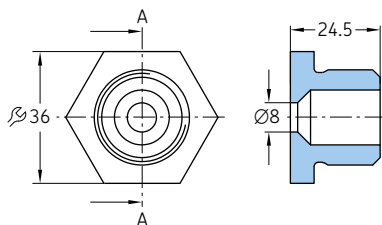

Order number	Designation	Material	Operating pressure max.		Weight	
			bar	psi	g	lb
995-001-620	COUPLING SOCKET	Steel, galvanized	100	1450	480	1.06
995-001-621	COUPLING PLUG	Steel, galvanized	100	1450	380	0.84
995-001-622	STUB	Steel, galvanized	100	1450	100	0.22
995-001-623	DUST COVER	Steel, galvanized	100	1450	55	0.12

## Valves



### Description

Several kind of valves are usually needed to operate automatic lubrication systems accurately. Intermittent or subsectioned systems only work if the right valves are installed. Valves specifically used in just one SKF system, such as in single-line lubrication systems, can be selected out of the respective SKF automatic lubrication system catalogues.

This catalogue chapter contains valves for use in multiple systems:

- Shut-off valves
- Safety valves
- Check valves
- Relief valves

In several applications, necessary valves may also come directly integrated in the pump unit, mounted in a valve block or as part of a reservoir unit.

### Features and benefits

- System component protection against excessive pressure and destruction
- Cost-efficient operation due to lubrication system subsectioning
- Shut-off valves allow manual activation or deactivation of independently operating machine zones

### Applications

- Small-to-medium machine tools
- Mobile on-road (fleet vehicles, on-road vehicles)
- Assembly/Automation, food packaging, part assembly lines
- Pulp and paper industry
- Injection molding
- General industry
- Heavy industry
- Etc.

# Relief valve

Connection diagram

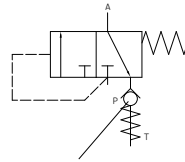

Check valve = residual pressure valve 0.5 bar

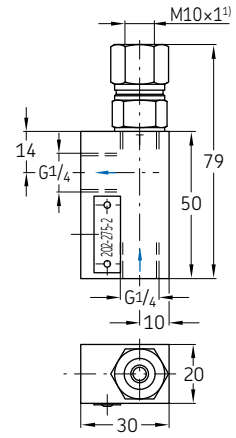

Order number	Designation	Residual pressure		Weight	
		bar	psi	g	lb
202-275-2	PRESS. RELIEF VALVE 0,5BAR G1/4	0,5	7.25	240	0.53

# Relief valves with bleed valve and safety valve

Fitted to reservoir

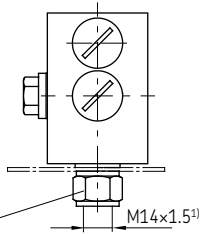

For P and R  
2 adapters each 408-160  
washers 508-108

<sup>1)</sup> Ports tapped for solderless tube connection

Relief valve circuit diagram

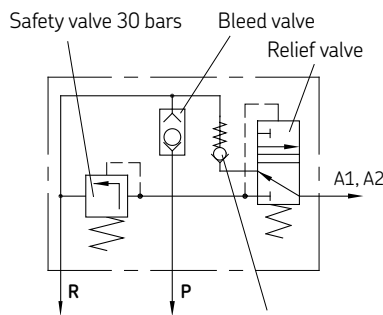

Check valve = residual pressure valve 0.5 bars

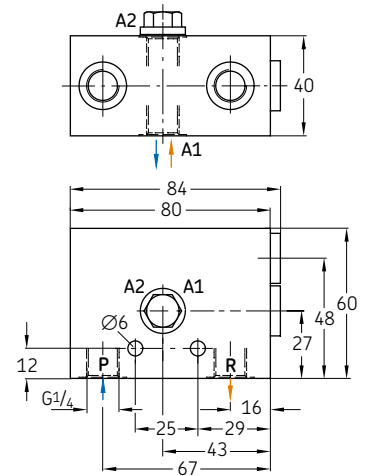

Order number	Designation	Tube Ø	Material	Residual pressure		Weight	
				bar	psi	g	lb
202-175-30	PRESS. RELIEF VALVE 30BAR R1/4	–	Aluminum	30	435	570	1.26
Adapters <sup>1)</sup>							
406-054	CONNECTING PIECE ST 6 G1/4AZN	6	Steel, galvanized	–	–	20	0.04
301-020	CONNECTING PIECE ST 8 G1/4AZN	8	Steel, galvanized	–	–	16	0.04
410-163	CONNECTING PIECE ST 10 - G1/4AZN	10	Steel, galvanized	–	–	30	0.07

<sup>1)</sup> Ports tapped for solderless tube connection

A = Outlet; P = Inlet; T (R) = Return

## Valves

# Pressure regulating valves, adjustable (poppet valve)

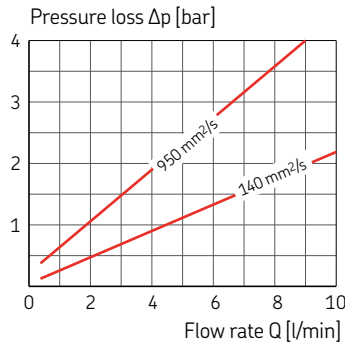

With increasing flow rate, the pressure upstream from the valve will also rise in accordance with the curves.

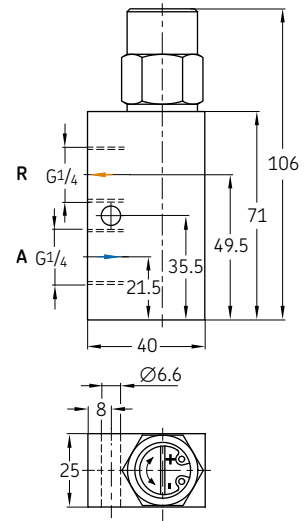

Order number	Designation	Adjustable pres. range		Operating pres. max.		Oil temperature		Viscosity range	Seal	Weight	
		bar	psi	bar	psi	°C	°F			g	lb
Steel, galvanized											
<b>WVN200-10E6</b>	PRES.REGUL.VALVE 1-6BAR NBR	1 to 6	14,5 to 87	40	580	80	176	20 to 1000	NBR	500	1.10
<b>WVN200-10E12</b>	PRES.REGUL.VALVE 3-12BAR NBR	3 to 12	43,5 to 174	40	580	80	176	20 to 1000	NBR	500	1.10
<b>WVN200-10E12-S8</b>	PRES.REGUL.VALVE 3-12BAR FPM	3 to 12	43,5 to 174	40	580	80	176	20 to 1000	FPM	500	1.10
<b>WVN200-10E25</b>	PRES.REGUL.VALVE 4-25BAR NBR	4 to 25	58 to 363	40	580	80	176	20 to 1000	NBR	500	1.10
<b>WVN200-10E25-S8</b>	PRES.REGUL.VALVE 4-25BAR FPM	4 to 25	58 to 363	40	580	80	176	20 to 1000	FPM	500	1.10
<b>WVN200-10E35</b>	PRES.REGUL.VALVE 4-35BAR NBR	4 to 35	58 to 510	40	580	80	176	20 to 1000	NBR	510	1.12
<b>WVN200-10E60</b>	PRES.REGUL.VALVE 12-60BAR NBR	12 to 60	174 to 870	70	1 015	80	176	20 to 1000	NBR	510	1.12
<b>WVN200-10E60-S8</b>	PRES.REGUL.VALVE 12-60BAR FPM	12 to 60	174 to 870	70	1 015	80	176	20 to 1000	FPM	510	1.12
General characteristics		Design: poppet valve with hydraulic cushioning directly controlled Lubricant: oil Connecting thread: G 1/4 Mounting position: optional									

## Adapters for valves

Fitted to reservoir

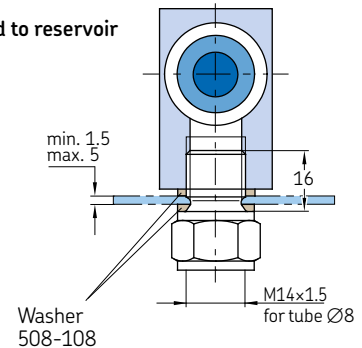

Order number	Designation	Description	Tube ØD	Material	Weight	
			mm		g	lb
<b>301-020</b>	CONNECTING PIECE ST 8 - G1/4AZN	for valves WVN200-10E6 ...10E35	8	Steel, galvanized	16	0.04
<b>410-163</b>	CONNECTING PIECE ST 10 - G1/4AZN	for valves WVN200-10E6 ...10E35	10	Steel, galvanized	30	0.07
<b>412-163</b>	CONNECTING PIECE ST 12 - G1/4AZN	for valves WVN200-10E6 ...10E35	12	Steel, galvanized	51	0.11
<b>508-108</b>	SEALING RING CU 13,3x17,9x1,5	for valves WVN200-10E6 ...10E35	-	Copper	1	0.00
<b>223-12477-6</b>	TB.FITT.ST GE 8-L G 1/4A CF	for valve WVN200-10E60	8	Steel, galvanized	35	0.08
<b>223-12272-9</b>	TB.FITT.ST GE10-L G 1/4A CF	for valve WVN200-10E60	10	Steel, galvanized	41	0.09
<b>508-108</b>	SEALING RING CU 13,3x17,9x1,5	for valve WVN200-10E60	-	Copper	1	0.00
<b>408-160</b>	CONNECTING PIECE ST 8 - G1/4AZN	adapters with long tube ends	-	Steel, galvanized	22	0.05



## Valves

# Pressure regulating valves, fixed pressure

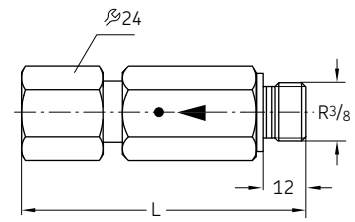

Order number	Designation	L	Material	Operating pressure max.		Weight	
				bar	psi	g	lb
		mm					
624-25465-1	VALVE SV -120-G3/8A Z	88	Steel, galvanized	120	1 740	241	0.53
624-25294-1	VALVE SV -350-G3/8A Z	84	Steel, galvanized	350	5 075	241	0.53
624-27092-1	VALVE SV -410-G3/8A Z	82	Steel, galvanized	410	5 950	241	0.53

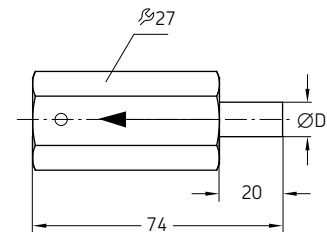

Order number	Designation	Pipe stud ØD	Material	Operating pressure max.		Weight	
				bar	psi	g	lb
		mm					
624-25478-1	VALVE SVP -200-S 6	6	Steel, galvanized	200	2 900	237	0.52
624-25479-1	VALVE SVP -350-S 6	6	Steel, galvanized	350	5 075	236	0.52
624-25480-1	VALVE SVP -200-S 8	8	Steel, galvanized	200	2 900	240	0.53
624-25481-1	VALVE SVP -350-S 8	8	Steel, galvanized	350	5 075	240	0.53
624-25482-1	VALVE SVP -200-S 10	10	Steel, galvanized	200	2 900	240	0.53
624-25483-1	VALVE SVP -350-S 10	10	Steel, galvanized	350	5 075	260	0.57

## Valves

# Pressure regulating valves

For flow rates from 0.5–2 l/min

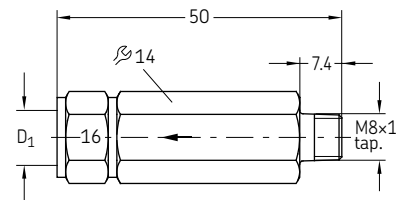

Order number	Designation	Tube Ø		Opening pressure		Marking	Material	Weight	
		D <sub>1</sub> <sup>1)</sup>		bar	psi			g	lb
		mm	mm	bar	psi			g	lb
WVN200-4A0.4	PRES.REGUL.VALVE 0,4BAR D4	4	M8×1	0,4	5,8	0,4	Steel, galvanized	45	0.10
WVN200-4A5	PRES.REGUL.VALVE 5BAR D4	4	M8×1	5	72,5	5	Steel, galvanized	47	0.10
WVN200-4A8	PRES.REGUL.VALVE 8BAR D4	4	M8×1	8	116	8	Steel, galvanized	46	0.10
WVN200-4A12	PRES.REGUL.VALVE 12BAR D4	4	M8×1	12	174	12	Steel, galvanized	45	0.10
WVN200-4A16	PRES.REGUL.VALVE 16BAR D4	4	M8×1	16	232	16	Steel, galvanized	46	0.10
WVN200-4A25	PRES.REGUL.VALVE 25BAR D4	4	M8×1	25	360	25	Steel, galvanized	46	0.10
WVN200-4A0.4-S1	PRES.REGUL.VALVE 0,4BAR D6	6	M10×1	0,4	5,8	0,4	Steel, galvanized	48	0.11

1) Ports tapped for solderless tube connection

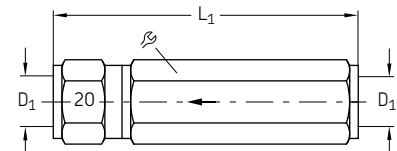

Order number	Designation	Tube Ø		L <sub>1</sub>	ϕ	Opening pressure		Weight		
		D <sub>1</sub> <sup>1)</sup>				bar	psi	g	lb	
		mm	mm	mm	mm	bar	psi	g	lb	
Steel, galvanized										
WVN200-6B0.5	PRES.REGUL.VALVE 0,5BAR D6	6	M10×1	61	14	0,5	7,25	5	57	0.13
WVN200-6B3	PRES.REGUL.VALVE 3BAR D6	6	M10×1	61	14	3	43,5	3	58	0.13
WVN200-6B8	PRES.REGUL.VALVE 8BAR D6	6	M10×1	61	14	8	116	8	58	0.13
WVN200-6B12	PRES.REGUL.VALVE 12BAR D6	6	M10×1	61	14	12	174	12	59	0.13
WVN200-6B16	PRES.REGUL.VALVE 16BAR D6	6	M10×1	61	14	16	232	16	60	0.13
WVN200-6B20	PRES.REGUL.VALVE 20BAR D6	6	M10×1	61	14	20	290	20	60	0.13
WVN200-6B40	PRES.REGUL.VALVE 40BAR D6	6	M10×1	61	14	40	580	40	59	0.13
WVN200-8B0	PRES.REGUL.VALVE 0,04BAR D8	8	M14×1,5	71	17	0,04	0,58	0	86	0.19
WVN200-8B3	PRES.REGUL.VALVE 3BAR D8	8	M14×1,5	71	17	3	43,5	3	87	0.19
WVN200-8B5	PRES.REGUL.VALVE 5BAR D8	8	M14×1,5	71	17	5	72,5	5	89	0.20
WVN200-8B12	PRES.REGUL.VALVE 12BAR D8	8	M14×1,5	71	17	12	174	12	89	0.20
WVN200-8B16	PRES.REGUL.VALVE 16BAR D8	8	M14×1,5	71	17	16	232	16	84	0.19
WVN200-8B20	PRES.REGUL.VALVE 20BAR D8	8	M14×1,5	71	17	20	290	20	90	0.20
WVN200-8B32	PRES.REGUL.VALVE 32BAR D8	8	M14×1,5	71	17	32	464	32	93	0.21
161-212-054 <sup>2)</sup>	PRES.REGUL.VALVE 20BAR D8	8	M14×1,5	84,5	17	20	290	20	107	0.24
WVN200-10B0	PRES.REGUL.VALVE 0,04BAR D10	10	M16×1,5	80	19	0,04	0,58	0	100	0.22
WVN200-10B0.5	PRES.REGUL.VALVE 0,5BAR D10	10	M16×1,5	80	19	0,5	7,25	5	126	0.28
WVN200-10B1	PRES.REGUL.VALVE 12BAR D10	10	M16×1,5	80	19	1,2	17,4	12	128	0.28
WVN200-10B32	PRES.REGUL.VALVE 32BAR D10	10	M16×1,5	80	19	32	464	32	130	0.29

<sup>1)</sup> Ports tapped for solderless tube connection

<sup>2)</sup> This valve is designed as a plunger valve. Because of this design it can also be used for regulating tasks, whereas the ball valves should be used as safety valves.

## Valves

# Pressure relief/regulating valves

For flow rates from 0.5–2 l/min

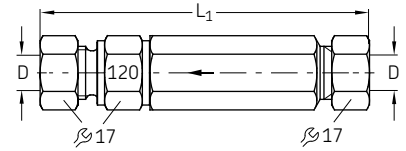

Order number	Designation	Tube Ø L <sub>1</sub>		Opening pressure		Marking	Material	Weight	
		mm	mm	bar	psi			g	lb
<b>WVN200-8D50</b>	PRES.REGUL.VALVE 50BAR D8	8	84	50	725	50	Steel, galvanized	130	0.29
<b>WVN200-8D75</b>	PRES.REGUL.VALVE 75BAR D8	8	84	75	1 090	75	Steel, galvanized	135	0.30
<b>WVN200-8D120</b>	PRES.REGUL.VALVE 120BAR D8	8	84	120	1 740	120	Steel, galvanized	130	0.29
<b>WVN200-8D220</b>	PRES.REGUL.VALVE 220BAR D8	8	84	220	3 190	220	Steel, galvanized	130	0.29
<b>WVN200-10D120-S1</b>	PRES.RELIEF VALVE 120 BAR D8/D10	10	87	120	1 740	120	Steel, galvanized	140	0.31
<b>WVN200-10D220-S1</b>	PRES.RELIEF VALVE 220 BAR D8/D10	10	87	220	3 190	220	Steel, galvanized	135	0.30

Cutting sleeve screw unions according to DIN 2353

## Shut-off valves

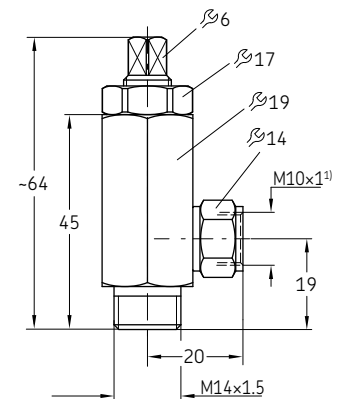

Order number	Designation	p max.		Max. temperature		Material	Weight	
		bar	psi	°C	°F		g	lb
<b>202-085-S</b>	SHUT-OFF VALVE 60BAR M14x1,5	60	810	80	176	Steel, galvanized	110	0.24

Direction of flow optional

## Valves

# Shut-off valves

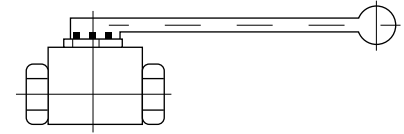

Order number	Designation	p max.		Connection	Nominal Ø DN	Material	Weight	
		bar	psi				g	lb
<b>235-13108-4</b>	BALL VALVE ST G 1/2 DN13 500 BAR	500	7 250	G 1/2 female	13	Steel, galvanized	640	1.41
<b>235-13114-1</b>	BALL VALVE ST D20 DN16 400 BAR	400	5 800	Tube Ø 20	16	Steel, galvanized	960	2.12

Direction of flow optional

**161-600-036**

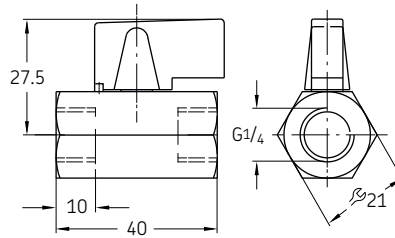

**UFZ.0097**

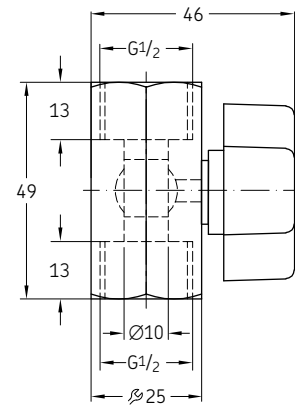

Order number	Designation	p max.		Max. temperature		Material	Weight	
		bar	psi	°C	°F		g	lb
<b>161-600-036</b>	BALL VALVE PN 16 G1/4 MS	16	232	90	194	Brass	80	0.18
<b>UFZ.0097</b>	BALL VALVE PN 10 G1/2 MS	10	145	90	194	Brass	150	0.33

Direction of flow optional

# Solenoid valves

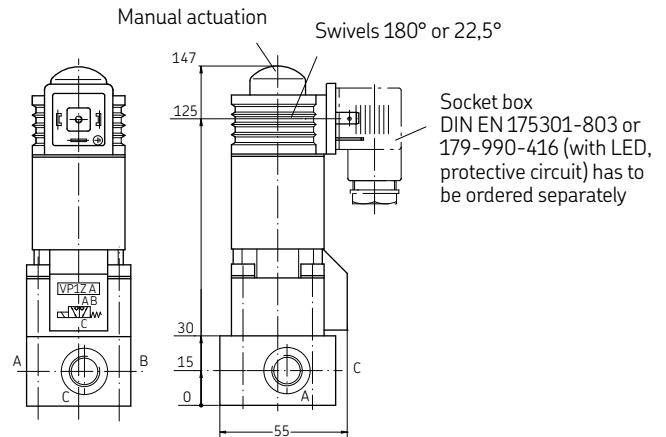

Order number	Designation	Type	Off Position	Operating voltage	Con- nection	p max.		Weight	
						bar	psi	kg	lb
525-32080-1	WAY VALVE WV-M-W2G-1/2- 24DC	2/2 way valve	normally closed	24 VDC	G 1/2	400	5 800	1,74	3.84
525-32082-1	WAY VALVE WV-M-W2G-1/2-230AC	2/2 way valve	normally closed	230 VAC	G 1/2	400	5 800	1,7	3.75
525-32081-1	WAY VALVE WV-M-W2G-1/2-110AC	2/2 way valve	normally closed	110 VAC	G 1/2	400	5 800	1,76	3.88
525-32083-1	WAY VALVE WV-M-W20-1/2- 24DC	2/2 way valve	normally open	24 VDC	G 1/2	400	5 800	1,76	3.88
525-32084-1	WAY VALVE WV-M-W20-1/2-230AC	2/2 way valve	normally open	230 VAC	G 1/2	400	5 800	1,69	3.73
525-32098-1	WAY VALVE WV-M-W20-1/2-110AC	2/2 way valve	normally open	110 VAC	G 1/2	400	5 800	1,81	3.99
525-32085-1	WAY VALVE WV-M-W3 -3/8- 24DC	3/2 way valve	-	24 VDC	G 3/8	400	5 800	1,37	3.02
525-32087-1	WAY VALVE WV-M-W3 -3/8-230AC	3/2 way valve	-	230 VAC	G 3/8	400	5 800	1,3	2.87
525-32086-1	WAY VALVE WV-M-W3 -3/8-110AC	3/2 way valve	-	110 VAC	G 3/8	400	5 800	1,38	3.04
161-110-031+924	WAY VALVE WV-M-W2G-1/4- 24DC	2/2 way valve	normally closed	24 VDC	G 1/4	500	7 250	1,28	2.82
161-120-064+924	WAY VALVE WV-M-W3 -1/4- 24DC	3/2 way valve	-	24 VDC	G 1/4	500	7 250	1,25	2.76

## Pressure gauges



### Description

Pressure gauges are mechanically operated instruments that visually display the pressure of the connected medium. In lubrication systems, they are used to show the pressure rate of air, oil or grease of either the pump or the pipe system. They are available in various pressure ranges for low-, medium- or high-pressure applications in all kinds of lubrication systems.

The following points must be considered in order to select the correct model:

- Pressure of the medium – the maximum pressure that could occur in the system shall not be higher than 2/3 of the indication range of the pressure range
- Pulsation of the pressure – use of liquid-filled gauges is highly recommended for measuring points with high dynamic pressure loads and areas with vibration
- Corrosive atmosphere – use of stainless steel pressure gauges is highly recommended
- If an electrical signal is desired – use of pressure gauges, including digital pressure indication, is highly recommended

### Features and benefits

- Visual and digital pump and system pressure monitoring
- Economical, reliable and virtually maintenance-free operation
- Wide range of pressure rates and sizes
- Liquid-filled gauges for dynamic operations available
- Stainless for operation in aggressive atmosphere available

### Applications

- All kinds of lubrication systems: low, middle mechanic and plant engineering
- Oil and grease lubrication systems
- Installation at the pump or at the end of the line

## Pressure gauges

### Standard pressure gauges

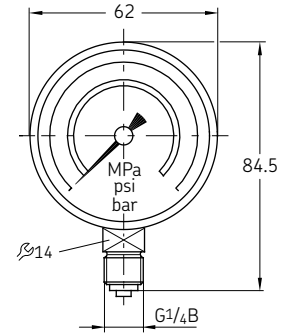

Order number	Designation	Indication range		Material	Weight	
		bar	psi		g	lb
169-101-004	PR.GAUGE D63 0-10 BAR G1/4A ABS	0-10	0-145	ABS housing	96	0.21
169-102-020	2) PR.GAUGE D63 0-25 BAR G1/4B ABS	0-25	0-360	ABS housing	90	0.20
169-104-020	2) PR.GAUGE D63 0-40 BAR G1/4B ABS	0-40	0-580	ABS housing	100	0.22
169-106-020	2) PR.GAUGE D63 0-60 BAR G1/4B ABS	0-60	0-870	ABS housing	83	0.18
169-110-020	2) PR.GAUGE D63 0-100 BAR G1/4B ABS	0-100	0-1 450	ABS housing	90	0.20
169-116-000	PR.GAUGE D63 0-160 BAR G1/4A ABS	0-160	0-2 320	ABS housing	94	0.21
169-125-020	2) PR.GAUGE D63 0-250 BAR G1/4B ABS	0-250	0-3 625	ABS housing	84	0.19

Washer, **order No. 248-610.02**, must be ordered separately for use in solderless tube connections acc. to DIN 3862.

2) Associated connecting pieces → page 60

### Pressure gauges with metrical thread

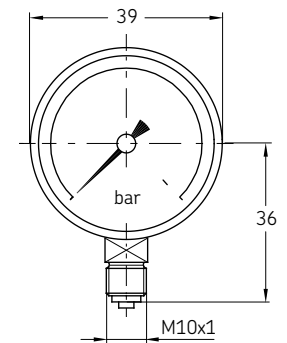

Order number	Designation	Indication range		Material	Weight	
		bar	psi		g	lb
24-1207-2204	PR.GAUGE 0-60 BAR M10x1	0-60	0-870	ABS housing	83	0.18

2) Associated connecting pieces → page 60

## Pressure gauges

# Damped pressure gauges with glycerin filling

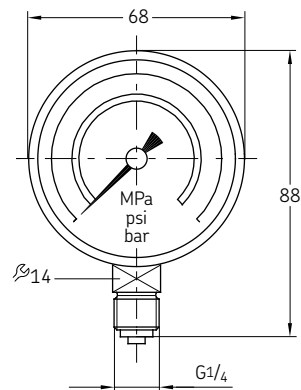

Order number	Designation	Mounting position	Indication range		Material	Weight	
			bar	psi		g	lb
169-102-015	PR.GAUGE D68 0- 25 BAR GLYCER G1/4B VA	vertically	0-25	0-360	Stainless steel housing	210	0.46
169-104-015	PR.GAUGE D68 0- 40 BAR GLYCER G1/4B VA	vertically	0-40	0-580	Stainless steel housing	200	0.44
169-106-015	PR.GAUGE D68 0- 60 BAR GLYCER G1/4B VA	vertically	0-60	0-870	Stainless steel housing	200	0.44
169-110-015	PR.GAUGE D68 0-100 BAR GLYCER G1/4B VA	vertically	0-100	0-1 450	Stainless steel housing	200	0.44
169-125-015	PR.GAUGE D68 0-250 BAR GLYCER G1/4B VA	vertically	0-250	0-3 625	Stainless steel housing	200	0.44
169-140-001	PR.GAUGE D62 0-400 BAR GLYCER G1/4B VA	vertically	0-400	0-5 800	Stainless steel housing	220	0.49

Washer, **order No. 248-610.02**, must be ordered separately for use in solderless tube connections acc. to DIN 3862.

# Damped pressure gauges with glycerin filling and visualization in red/green

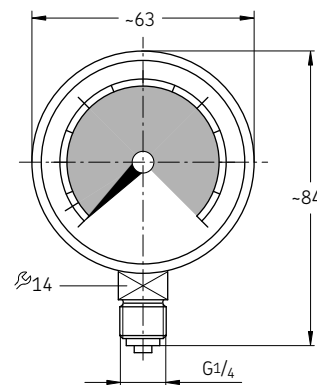

Order number	Designation	Mounting position	Indication range		Material	Weight	
			bar	psi		g	lb
169-101-607	PR.GAUGE D63 0-16 BAR GLYZ. G1/4B VA	vertically	0-16	0-230	Stainless steel housing	166	0,37
169-106-011	PR.GAUGE D63 0-60 BAR GLYZ. G1/4B VA	vertically	0-60	0-870	Stainless steel housing	220	0,49
169-110-010	PR.GAUGE D63 0-100 BAR GLYZ. G1/4B VA	vertically	0-100	0-1 450	Stainless steel housing	174	0,38

Washer, **order No. 248-610.02**, must be ordered separately for use in solderless tube connections acc. to DIN 3862.



## Pressure gauges

### Damped pressure gauges with restrictor

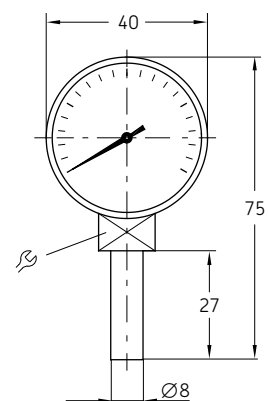

Order number	Designation	☞ mm	Restrictor	Lubricant	Indication range		Material	Weight	
					bar	psi		g	lb
248-602.25	PR.GAUGE D40 0-10 BAR TUBE 8	4kt 12	-	-	0-10	0-145	Steel housing, black	66	0.15
169-102-506 1)	PR.GAUGE D40 0-25 BAR TUBE 8	12	0,4	-	0-25	0-360	Steel housing, black	62	0.14
248-602.20	PR.GAUGE D40 0-40 BAR TUBE 8	12	-	Grease	0-40	0-580	Steel housing, black	59	0.13
169-104-008 1)	PR.GAUGE D40 0-40 BAR TUBE 8	4kt 14	0,4	Oil	0-40	0-580	Steel housing, black	61	0.13
169-106-004	PR.GAUGE D40 0-60 BAR TUBE 8 ABS	4kt 14	-	-	0-60	0-870	ABS housing	60	0.13

Fixed by means of a double-tapered sleeve and socket union (solderless tube connection) in counterbore acc. to DIN 3854/DIN 3862.

1) undamped design

### High-pressure gauges

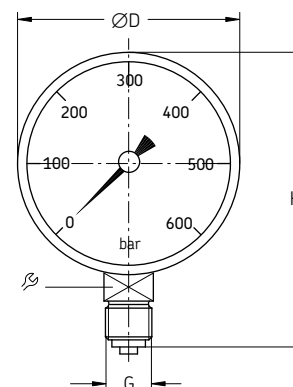

Order number	Designation	ØD	G	H	Mounting position	Indication range		Weight	
						bar	psi	g	lb
Steel housing, black									
234-13132-7	PR.GAUGE D 63 0- 400 BAR GLYZ.G1/4B BOT	63	G 1/4 bottom	84,5	vertically	0-400	0-5800	200	0,44
234-13132-8	PR.GAUGE D 63 0- 400 BAR G1/4B	63	G 1/4 bottom	84,5	vertically	0-400	0-5800	100	0,22
234-13156-6	PR.GAUGE D 63 0- 600 BAR	63	G 1/4 bottom	84,5	vertically	0-600	0-8700	210	0,46
234-13182-7	PR.GAUGE D 63 0- 600 BAR GLYZ.G1/4B BOT	63	G 1/4 bottom	84,5	vertically	0-600	0-8700	200	0,44
234-10396-2	PR.GAUGE D100 0- 400 BAR	100	G 1/2 bottom	133	vertically	0-400	0-5800	601	1,33
234-13101-2	PR.GAUGE D100 0- 600 BAR G1/2A	100	G 1/2 bottom	133	vertically	0-600	0-8700	560	1,23
234-13101-4	PR.GAUGE D100 0- 600 BAR G1/2B GLYZER	100	G 1/2 bottom	133	vertically	0-600	0-8700	860	1,90
Stainless steel housing									
234-10396-9	PR.GAUGE D 63 0- 400 BAR G1/4(BAR/PSI)VA	63	G 1/4 bottom	84,5	vertically	0-400	0-5800	200	0,44
234-13182-8	PR.GAUGE D 63 0- 400BAR G1/4B BACK VA	63	G 1/4 back	63	vertically	0-400	0-5800	220	0,49
234-10898-4	PR.GAUGE D100 0- 400 BAR+PSI GLYZ.1.4404	100	G 1/2 bottom	133	vertically	0-400	0-5800	993	2,19

## Reservoirs



### Description

For technical reasons, all reservoirs shown in this catalogue can only be used for oil. Grease reservoirs require additional technical features that make a combination of reservoir and pump necessary. The reservoirs shown are available in either plastic or metal designs. The advantage of the plastic containers is that the oil filling level is clearly visible through the transparent reservoir. Metal reservoirs from 6 liters (1.5 gal) and larger can be equipped with external oil level indicators. It is also possible to monitor the minimum or maximum oil level electrically via float switches. Depending on the oil used, the sealing material (NBR or FPM) should be selected.

### Features and benefits

- Available in sizes ranging from 3 litres to 100 litres on request
- All reservoirs are equipped with a screen at the filler socket (exception: 1 litre tank screen at the outlet), which reliably prevents foreign particles from entering
- Simple and proven design for use in all kinds of automatic oil lubrication systems
- Virtually leakage-free storage of oil
- Easy manual or digital fill-level monitoring

### Applications

- All automatic oil lubrication systems
- Pulp and paper industry
- Automobile presses
- Food and beverage
- Automation
- Printing
- Metals
- Etc.

## Reservoirs

# Plastic reservoirs

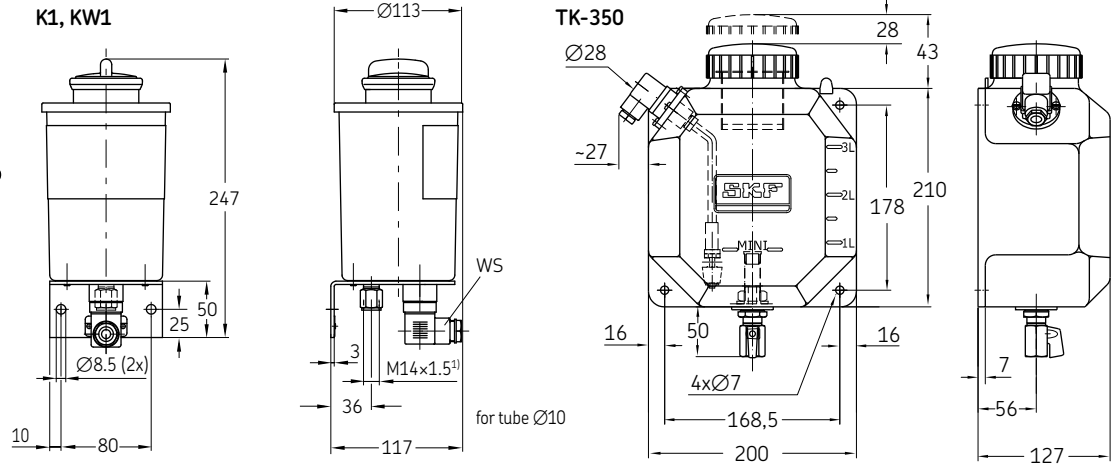

1) Ports tapped for solderless tube connection

Order number	Designation	Reservoir Capacity		Level indicator	Type of contact	Electrical connector	Seal material	Weight	
		l	gal.					kg	lb
<b>K1</b>	OIL RESERVOIR ASSY. PL 1YN	1	0.26	–	–	–	NBR	0,70	1.54
<b>KW1</b>	OIL RESERVOIR ASSY. PL 1YL (NO)	1	0.26	Min. filling level	NO	Rectangular connector	NBR	0,76	1.68
<b>KW1-S2</b>	OIL RESERVOIR ASSY. PL 1YL (NC)	1	0.26	Min. filling level	NC	Rectangular connector	NBR	0,80	1.76
<b>TK-350-V</b>	OIL RESERVOIR ASSY. PL 3,7L	3,7	0.97	–	–	–	NBR	0,93	2.05
<b>TK-350-VM</b>	OIL RESERVOIR ASSY. PL 3,3L (NO)	3,3	0.87	Min. filling level	NO	Wire with appr. 0,95 m length	NBR	1,06	2.33
<b>TK-350-VMC</b>	OIL RESERVOIR ASSY. PL 3,3L (NO)	3,3	0.87	Min. filling level	NO	Rectangular connector	NBR	1,13	2.49

### Plastic reservoir, 3 liter

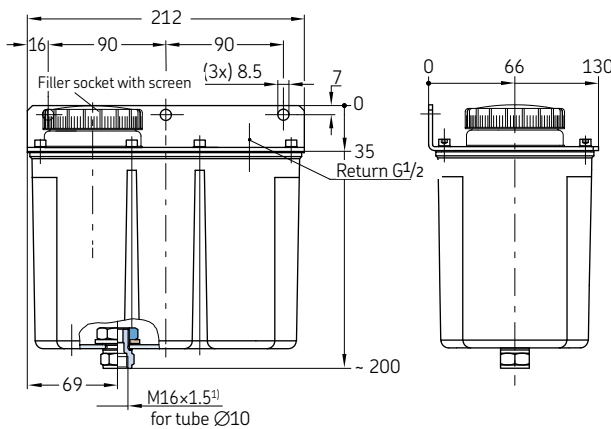

1) Ports tapped for solderless tube connection

### Plastic reservoir, 6 liter

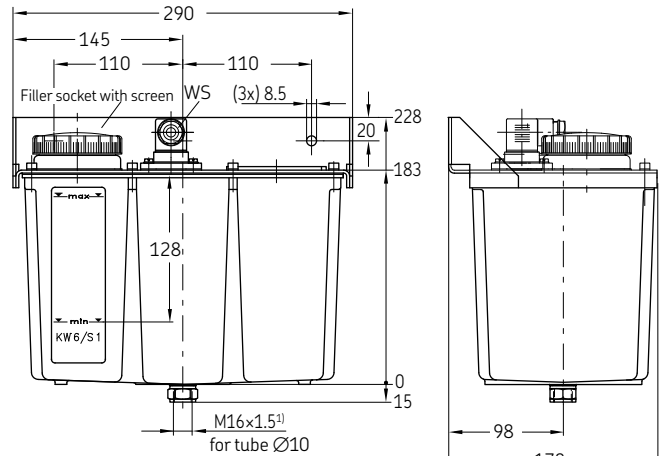

1) Ports tapped for solderless tube connection

Order number	Designation	Reservoir Capacity		Level indicator WS	Type of contact	Seal material	Weight	
		l	gal.				kg	lb
<b>K3-S2</b>	OIL RESERVOIR ASSY. PL 3YN	3	0.79	–	–	NBR	1,34	2.95
<b>KW3-S1</b>	OIL RESERVOIR ASSY. PL 3YL (SPDT)	3	0.79	Min. filling level	Changeover	NBR	1,63	3.59
<b>K6-S5</b>	OIL RESERVOIR ASSY. PL 6YN	6	1.58	–	–	NBR	2,28	5.04
<b>KW6-S1</b>	OIL RESERVOIR ASSY. PL 6YL (SPDT)	6	1.58	Min. filling level	Changeover	NBR	2,58	5.70
<b>KW6-S2</b>	OIL RESERVOIR ASSY. PL 6YLP (NC)	6	1.58	Min. filling with advance warning	2NCs	NBR	2,50	5.51

## Reservoirs

## Plastic reservoirs

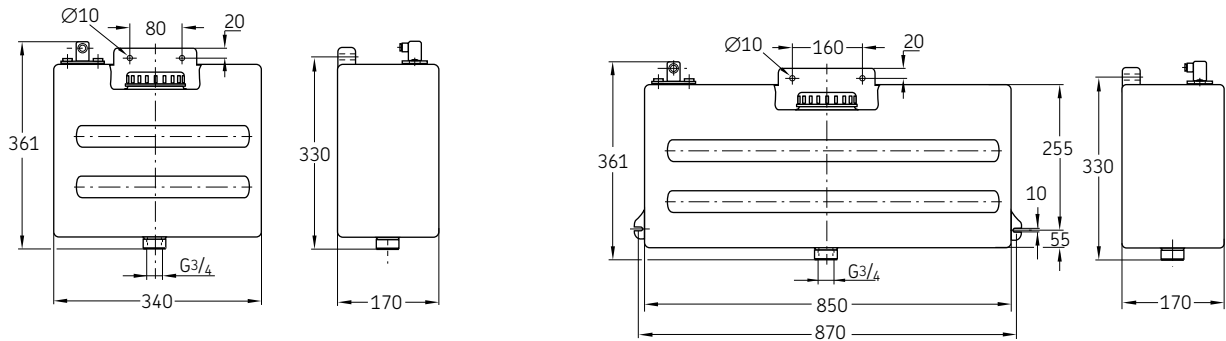

Order number	Designation	Reservoir capacity		Level indicator WS	Type of contact	Weight	
		l	gal.			kg	lb
651-28691-1	OIL RESERVOIR PL 13YL F.PMA	13	2.86	Minimum filling level	Changeover	2,2	4.85
651-29124-1	OIL RESERVOIR PL 13YN F.PMA	13	2.86	–	–	2	4.40
651-28685-1	OIL RESERVOIR PL 36YL F.PMA	36	7.9	Minimum filling level	Changeover	4,251	9.37

## Oil trough with shut-off valve

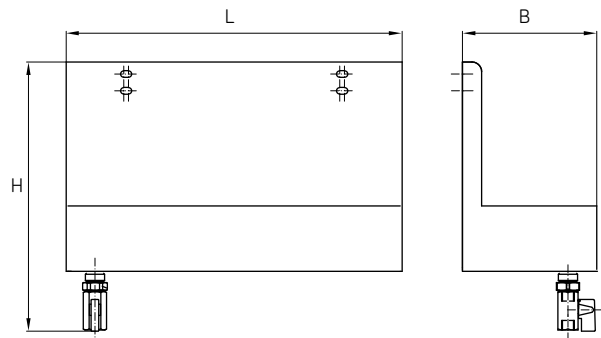

Order number	Designation	Reservoir capacity		L	B	H
		l	gal.			
B3.U21	OIL TROUGH 3L	3	0,792	350	280	140
B7.U271	OIL TROUGH 6L	6	1,585	400	380	190

## Reservoirs

### Metal reservoirs

Metal reservoir, 3 liter

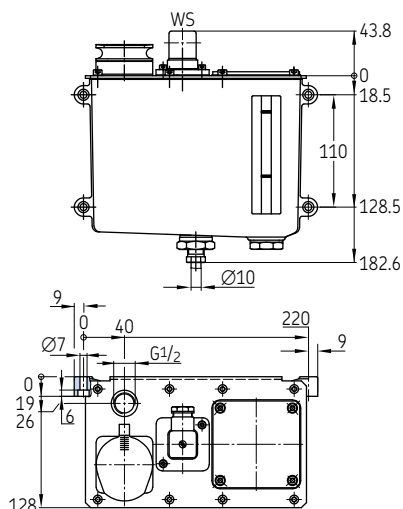

Metal reservoir, 6 liter

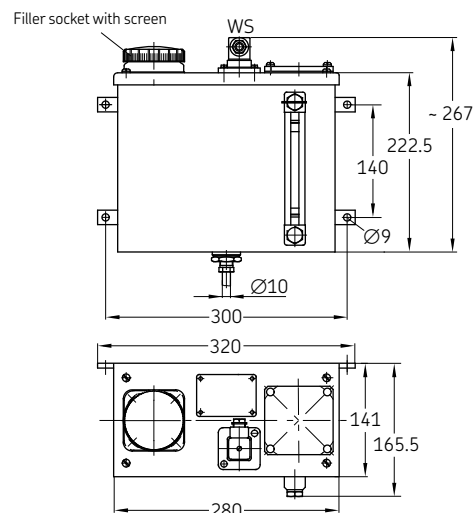

Order number	Designation	Reservoir capacity		Level indicator WS	Type of contact	Seal material	Weight	
		l	gal.				kg	lb
<b>BW3-2-S1</b>	OIL RESERVOIR ASSY. ST 3YL	3	0.79	Min. filling level	Changeover	NBR	2,24	4.94
<b>B7</b>	OIL RESERVOIR ASSY. ST 6YN	6	1.58	–	–	NBR	4,9	10.80
<b>BW7-S6</b>	OIL RESERVOIR ASSY. ST 6YBN	6	1.58	Min. and max. filling level	2 NCs	NBR	5,12	11.29
<b>BW7-S7</b>	OIL RESERVOIR ASSY. ST 6YLP (2xNC)	6	1.58	Min. filling level with advance warning	2 NCs	NBR	5,2	11.47
<b>BW7-S8</b>	OIL RESERVOIR ASSY. ST 6YL (SPDT)	6	1.58	Min. filling level	Changeover	FPM	5,11	11.27
<b>BW7-S11</b>	OIL RESERVOIR ASSY. ST 6YP (2xSPDT)	6	1.58	Min. filling level with advance warning	1 NO, 1 NC	NBR	4,97	10.96
<b>BW7-S14</b>	OIL RESERVOIR ASSY. ST 6YP (NC/NO))	6	1.58	Min. filling level with advance warning	1 NO, 1 NC	NBR	5,2	11,47
<b>162-310-005</b>	OIL RESERVOIR ASSY. ST 6YL (SPDT)	6	1.58	Min. filling level	Changeover	NBR	4,96	10,94

### Oil level gauges for metal reservoirs

Order number	Designation	L <sub>1</sub>	L <sub>2</sub>	Reservoir Capacity		Weight	
		mm	mm	Liters	gal.	g	lb
<b>995-003-044</b>	OIL LEVEL GAUGE L=127MM	152	127	6	1.58	146	0.32
<b>995-003-040</b>	OIL LEVEL GAUGE L=165MM	190	165	6	1.58	158	0.35
<b>995-003-041</b>	OIL LEVEL GAUGE L=190MM	215	190	15 and 30	3.96 and 7.92	170	0.37
<b>995-003-042</b>	OIL LEVEL GAUGE L=254MM	279	254	50	13.21	190	0.42
<b>995-003-043</b>	OIL LEVEL GAUGE L=280MM	305	280	100	26.42	199	0.44

Type: NBR, FKM (FPM) on request

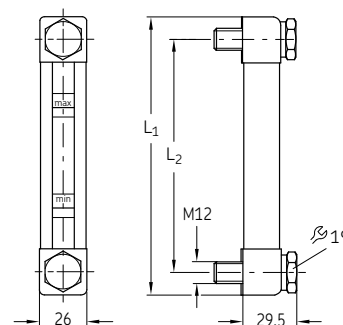

## Lubricating nipples

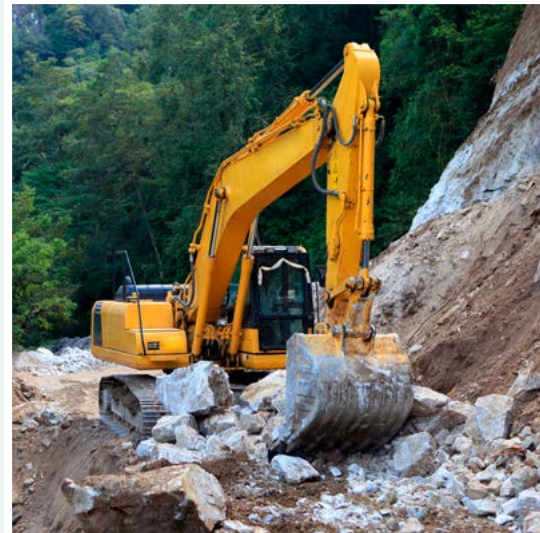

### Description

Grease nipples provide a standardized connection to the grease gun and are therefore an important part for servicing and maintaining bearings. They also protect the lubrication point from external influences such as dirt and water.

### Features and benefits

- Our standard program includes the most common hydraulic and flat grease nipples according to DIN 74412 and DIN 3404
- Available in galvanized steel or stainless steel

### Applications

- Linear guides
- Bearings, bearing blocks
- Drive shafts, cardan shafts
- Axles

# Hydraulic grease nipples according to DIN 71412

Straight

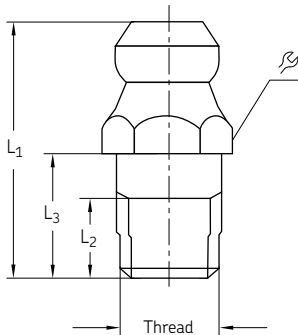

Angle, 45°

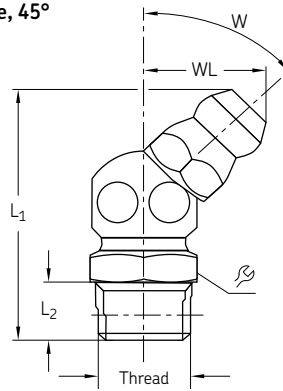

Angle, 90°

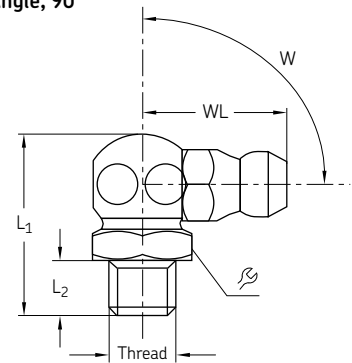

Order number	Designation	Form	Thread	mm	Material	Operating pressure max.		Weight (100 pcs)	
						bar	psi	g	lb
Steel, galvanized									
251-14040-1	HYDRAULIC LUBR.FITT. ST AR 1/8 Z	Straight	R 1/8	11	Steel, galvanized	350	5 080	600	1.32
996-001-890	HYDRAULIC LUBR.FITT. ST AM 10X1,0 Z	Straight	M10×1	11	Steel, galvanized	350	5 080	500	1.10
251-14109-3	HYDRAULIC LUBR.FITT. ST BR 1/4 Z	Angle, 45°	R 1/4	14	Steel, galvanized	350	5 080	1 800	3.97
251-14045-1	HYDRAULIC LUBR.FITT. ST BR 1/8 Z	Angle, 45°	R 1/8	11	Steel, galvanized	350	5 080	1 200	2.65
251-14040-2	HYDRAULIC LUBR.FITT. ST CR 1/8 Z	Angle, 90°	R 1/8	11	Steel, galvanized	350	5 080	1 200	2.65
251-14044-8	HYDRAULIC LUBR.FITT. ST CR 1/4 Z	Angle, 90°	R 1/4	14	Steel, galvanized	350	5 080	1 200	2.65
Stainless steel									
251-14073-9	HYDR.LUBR.FITT.+CHECK VALVE A2 1/8	Straight	R 1/8	11	Stainless steel 1.4305	400	5 800	800	1.76
251-14109-2	HYDRAULIC LUBR.FITT. A2 AR 1/8 Z	Straight	R 1/8	11	Stainless steel 1.4305	350	5 080	600	1.32
251-10309-1	HYDRAULIC LUBR.FITT. A2 AR 1/4 Z	Straight	R 1/4	14	Stainless steel 1.4305	350	5 080	1 200	2.65
251-10780-2	HYDRAULIC LUBR.FITT. A2 AM 10X1,0 Z	Straight	M10×1	11	Stainless steel 1.4305	350	5 080	500	1.10
251-14063-4	HYDRAULIC LUBR.FITT. A2 BR 1/8 Z	Angle, 45°	R 1/8	11	Stainless steel 1.4305	350	5 080	1 200	2.65
251-14063-9	HYDRAULIC LUBR.FITT. A2 CR 1/8 Z	Angle, 90°	R 1/8	11	Stainless steel 1.4305	350	5 080	1 200	2.65

# Button-head grease nipples according DIN 3404

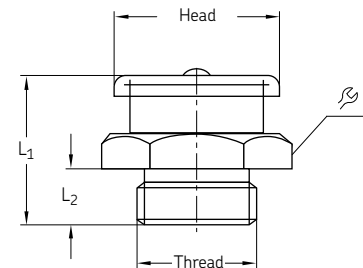

Order number	Designation	Head Ø	Thread	mm	Material	Operating pressure max.		Weight (100 pcs)	
						bar	psi	g	lb
251-14040-5	BUTTON HEAD LUBR.FITT.ST AG 1/8-16Z	16	G 1/8	17	Steel, galvanized	350	5 800	1 700	3.75
251-14040-4	BUTTON HEAD LUBR.FITT.ST AG 1/4-16Z	16	G 1/4	17	Steel, galvanized	350	5 800	1 900	4.19
251-10309-2	BUTTON HEAD LUBR.FITT.ST AG 3/8-16Z	16	G 3/8	17	Steel, galvanized	350	5 800	2 000	4.41
251-14063-1	BUTTON HEAD LUBR.FITT.ST AG 1/4-22Z	22	G 1/4	22	Steel, galvanized	350	5 800	4 000	8.82
251-14040-3	BUTTON HEAD LUBR.FITT.ST AG 3/8-22Z	22	G 3/8	22	Steel, galvanized	350	5 800	4 000	8.82
251-14045-8	BUTTON HEAD LUBR.FITT.ST AM10X1,0-16Z	16	M10×1	22	Steel, galvanized	350	5 800	1 700	3.75

## Lubricating nipples

# Lubrication fitting block

532-32248-1

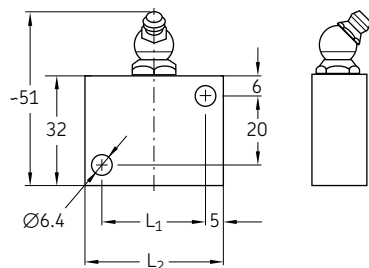

532-32454-1

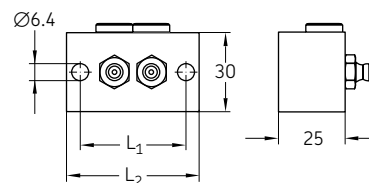

Order number	Designation	Ports for lubricating nipples	L <sub>1</sub>	L <sub>2</sub>	Material	Operating pressure max.		Weight	
			mm	mm		bar	psi	g	lb
532-32248-1	LUBR.FITT.BLOCK W.1 FITT. R1/8 45 DEGREE	1	30	40	Steel, galvanized	400	5 800	160	0.35
504-37184-2	LUBR.FITT.BLOCK W.1 FITT. R1/4" 90 DEGREE	1	30	40	Steel, galvanized	400	5 800	217	0.48
504-37210-1	LUBR.FITT.BLOCK 2 FITT. R1/8	2	40	50	Steel, galvanized	400	5 800	132	0.29
504-37211-1	LUBR.FITT.BLOCK 3 FITT. R1/8	3	60	70	Steel, galvanized	400	5 800	177	0.39
532-32454-1	LUBR.FITT.BLOCK W. 2 FITT. R1/8	2	40	50	Steel, galvanized	400	5 800	331	0.73
432-70024-1	LUBR.FITT.BLOCK 2 CONN.R1/8 HORIZ./VERTIC	2 <sup>1)</sup>	40	50	Steel, galvanized	400	5 800	236	0.52

<sup>1)</sup> Two lubricating nipple connections; corresponding tapered grease nipple order no. 251-14045-1

## Holder with lubricating nipple and fitting

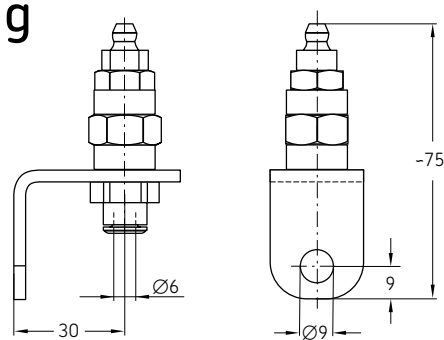

Order number	Designation	Ports for lubricating nipples	L <sub>1</sub>	Material	Operating pressure max.		Weight	
			mm		bar	psi	g	lb
532-32131-1	HOLDER W. HYDR. LUBR. FITTING	1	40	Steel, galvanized	400	5 800	93	0.21



## Lubricating nipples

### Lubrication nipple manifolds

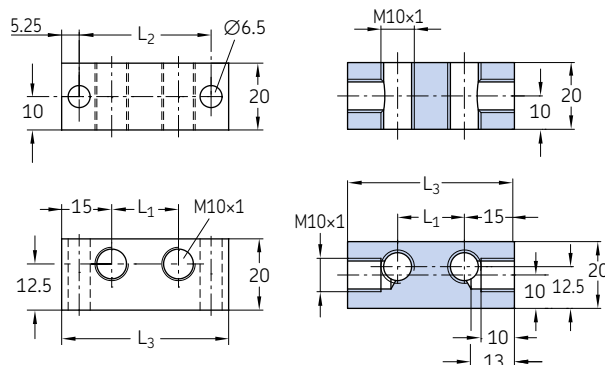

Order number	Designation	L <sub>1</sub>	L <sub>2</sub>	L <sub>3</sub>	Number of threaded holes	Material	Operating pressure max.		Weight	
							bar	psi	g	lb
		mm	mm	mm						
871-340-006	LUBRICATION BAR 1x M10x1	–	19,5	30	1	Steel, galvanized	400	5 800	72	0.16
871-340-008 <sup>1)</sup>	LUBRICATION BAR 2x M10x1	–	19,5	30	1	Steel, galvanized	400	5 800	70	0.15
871-360-006	LUBRICATION BAR 2x M10x1	20	39,5	50	2	Steel, galvanized	400	5 800	120	0.26
871-360-008 <sup>1)</sup>	LUBRICATION BAR 4x M10x1	20	39,5	50	2	Steel, galvanized	400	5 800	120	0.26
871-380-006	LUBRICATION BAR 3x M10x1	20	40	70	3	Steel, galvanized	400	5 800	180	0.40
871-380-008	LUBRICATION BAR VA 3x M10x1	20	40	70	3	Stainless steel 1.4301	400	5 800	180	0.40
871-390-020	LUBRICATION BAR 10x M10x1	20	199,5	210	10	Steel, galvanized	400	5 800	530	1.17
871-390-023	LUBRICATION BAR 13x M10x1	20	200	270	13	Steel, galvanized	400	5 800	685	1.51

<sup>1)</sup> Nipple connection; corresponding tapered grease nipple with valve, order no. 996-001-890

### Lubricating nipple box



Thread	Type	Quantity
M6x1	straight	30
M8x1	straight	20
M10x1	straight	10
G 1/8	straight	10
M6x1	45°	5
M8x1	45°	10
M10x1	45°	5
G 1/8	45°	5
M6x1	90°	5
M8x1	90°	10
M10x1	90°	5
G 1/8	90°	5

Order number	Designation	Material	Operating pressure max.	
			bar	psi
LAGN 120	LUBRICATION NIPPLE BOX LAGN 120	Steel, zinc plated, hardened and blue chromed	400	5 800



## Description

These easy-to-service lubricant filters consist of a housing and an integrated screen. Grease filters have pressure ratings up to 400 bar (5800 psi) and allow flow rates up to 24 dm<sup>3</sup>/hour (6.3 US gal/hour), oil and fluid grease filters allow 2 l/min.

Galvanized and chromate-treated lubricant filter units are available with hydraulic lubrication fittings for lubrication pump reservoir filling. They are also suitable for upstream installation in lubrication systems with divider valves and for outlet connection with outside diameters of 6 mm.

## Features and benefits

- Prevents system or component failures and extends system life to significant reduction of solids
- Economical, reliable and maintenance-friendly operation
- Compact and modular design mountable directly into pipes
- Wide range of volumetric flow levels and grades of filtration
- Optimized service handling by replacing of filter elements only
- Dirt monitoring of filter elements as an option
- Oil, fluid grease and grease filters

## Applications

- General mechanic and plant engineering
- Ship building and offshore industry
- Pulp and paper industry
- Heavy industry

# Screen filters for oil and fluid grease

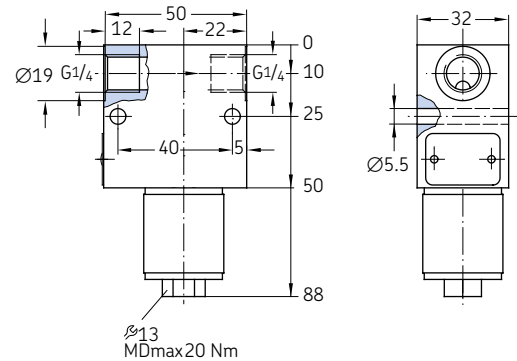

Order number	Designation	Lubricant	Filter rating	Connection thread	Material	Operating pressure max.		Weight	
						bar	psi	kg	lb
			µm						
213-870	FILTER	FLUID GREASE NLGI CLASS 000, 00	63	G 1/4	Aluminum	60	870	0,31	0,68
213-870F	FILTER	FLUID GREASE NLGI CLASS 000, 00	160	G 1/4	Aluminum	60	870	0,31	0,68
213-880	FILTER	OIL	25	G 1/4	Aluminum	60	870	0,31	0,68
213-930F	FILTER	FLUID GREASE NLGI CLASS 000, 00	160	G 1/4	Aluminum	60	870	1,27	2,80

# Filter elements for oil and fluid grease filters

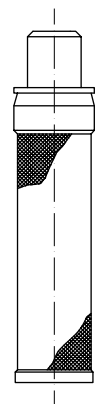

Order number	Designation	Lubricant	Filter rating	Operating pressure max.	
				bar	psi
			µm		
213-870.U1	FILTER ELEMENT FOR 213-870	Fluid grease NLGI class 000, 00	63	60	870
213-870.U2	FILTER ELEMENT FOR 213-870F	Fluid grease NLGI class 000, 00	160	60	870
213-880.U1	FILTER ELEMENT FOR 213-880	Oil	25	60	870
213-870.U2	FILTER ELEMENT FOR 213-930F	Fluid grease NLGI class 000, 00	160	60	870

## Filters

# Screen filters for grease

628-36062-3

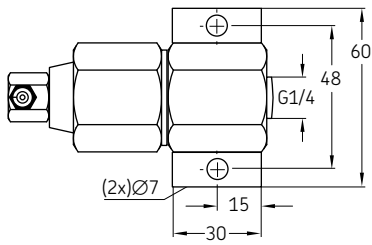

628-25531-2

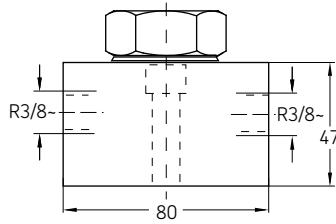

528-36045-6

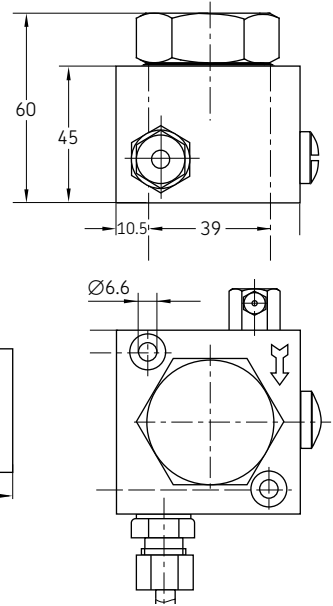

Order number	Designation	Tube ØD	Thread	Material	Operating pressure max.		Weight	
					bar	psi	g	lb
628-36062-3	Type SF 1-G 1/4 + 90° Nipple	–	G 1/4	Steel, galvanized	350	5 080	540	1.19
628-26452-2	Type SF 1-G 1/4	–	G 1/4	Steel, galvanized	350	5 080	440	0.97
428-21544-1	Coarse strainer (replacement part)	–	–	Steel, galvanized	350	5 080	2	0.005
528-36045-6	Filter unit with nipple and tube connection	6	–	Steel, galvanized	350	5 080	1 400	3.09
528-31341-3	Filter unit G 1/4 female	–	G 1/4	Steel, galvanized	400	5 800	1 280	2.82
628-25531-2	Filter unit G 3/8 female	–	G 3/8	Steel, galvanized	400	5 800	2 470	5.45

# Filter elements for grease filter units

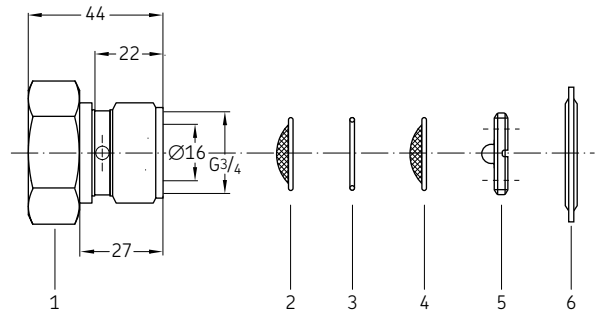

Order number	Designation	Item number	Material	Operating pressure max.		Weight	
				bar	psi	g	lb
428-21543-2	Hollow screw	1	Steel, galvanized	350	5 080	284	0.63
428-21544-1	Coarse strainer, fineness of filtration 410 µm	2	Brass	350	5 080	2	0.005
428-21546-2	Spacing ring	3	Spring steel	350	5 080	2	0.005
428-21545-1	Fine strainer, fineness of filtration 270 µm	4	Brass	350	5 080	2	0.005
303-17546-1	Threaded ring	5	Steel	350	5 080	12	0.03
220-12238-3	U-shit sealing ring	6	NBR	350	5 080	7	0.02

## Brushes

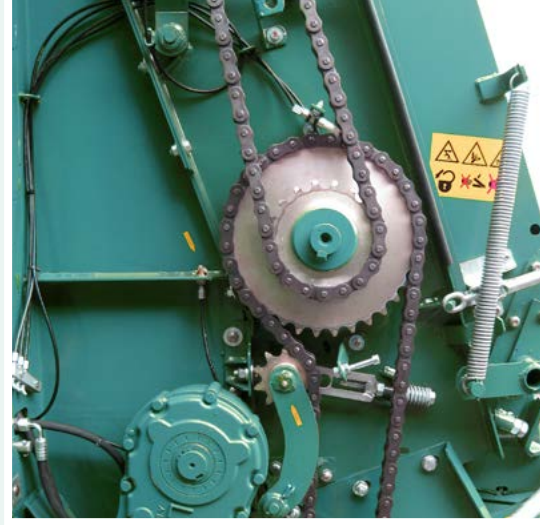

### Description

Brushes are used as lubricant applicators in lubrication systems. Regardless of the type of lubrication system, the applicators are always located at the end of the line and directly at the lubrication point. They are a simple and inexpensive solution for many applications, such as in chain lubrication. When using a brush, the entire chain is evenly coated with a protective film of lubricant. This keeps the chain supple and protects it from corrosion.

### Features and benefits

- Simple and inexpensive solution for many lubrication applications
- Accurate dosage, regardless of oil viscosity and flow resistance
- Lubricates the entire conveyor chain, not just the connecting points of the chain links

### Applications

- Conveyors for sorting, cleaning, cooking and pasteurizing fruits and vegetables
- Dryers, smokers and conveyors for meat processing
- Conveyors for material transport
- Ovens, boilers, dryers
- Freezers

# Brushes

## UC, 233, 068874

UC-1066-10

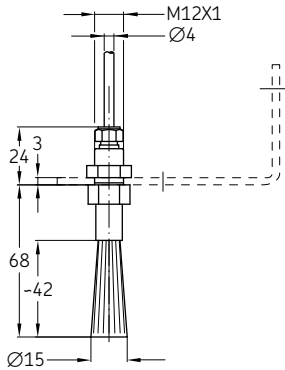

UC-1066-14

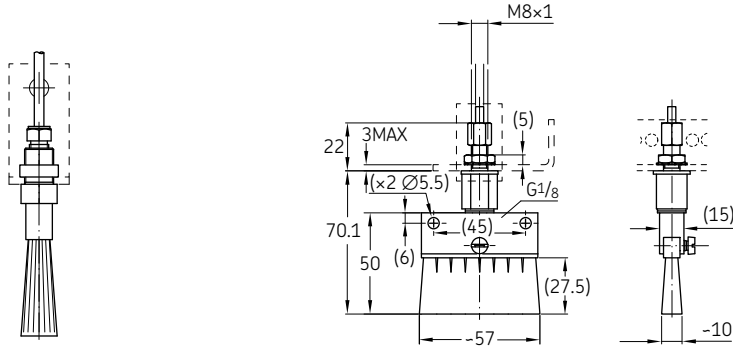

Order number	Designation	Shape	Tube ØD	Shape size	Temperature		Material	Fixation Weight		
					°C	°F		mm	g	lb
UC-1066-01	OIL BRUSH BRISTLE, 55x16	Rectangle	4 mm	55x16	10 to 60	50 to 140	Bristle	Ø8,5	110	0.24
UC-1066-02	OIL BRUSH MS, 55x16	Rectangle	4 mm	55x16	10 to 200	50 to 392	Brass	Ø8,5	160	0.35
UC-1066-03	OIL BRUSH BRISTLE, D30	Circle	4 mm	Ø30	10 to 60	50 to 140	Bristle	Ø19	85	0.19
UC-1066-04	OIL BRUSH BRISTLE, D15	Circle	4 mm	Ø15	10 to 60	50 to 140	Bristle	Ø12,5	45	0.10
UC-1066-05	OIL BRUSH PA6, D15	Circle	4 mm	Ø15	10 to 80	50 to 176	Polyamide 6.6	Ø12,5	45	0.10
UC-1066-06	OIL BRUSH PA6, 55x16	Rectangle	4 mm	55x16	10 to 80	50 to 176	Polyamide 6.6	Ø12,5	45	0.10
UC-1066-10	OIL BRUSH MS, D15	Circle	4 mm	Ø15	10 to 200	50 to 392	Brass	-	59	0.13
UC-1066-14	OIL BRUSH MS, 55x16	Rectangle	4 mm	55x16	10 to 300	50 to 572	Brass	-	-	-
233-14419-1	OIL BRUSH BZ MODEL SPF 57 G 1/8	Rectangle	G 1/8	55x16	10 to 200	50 to 392	Brass	2xØ5,5	62	0.14
233-13651-1	OIL BRUSH MS L=CA 47MM R1/8	Circle	R 1/8	Ø20	10 to 200	50 to 392	Brass	Ø20	20	0.04
233-13651-6	OIL BRUSH V2A MODEL SPR16/30/53 G 1/8	Circle	G 1/8	Ø16	10 to 200	50 to 392	Stainless steel	Ø20	35	0.08
233-13651-7	OIL BRUSH V2A MODEL SPR30/45/70 G 1/8	Circle	G 1/8	Ø30	10 to 200	50 to 392	Stainless steel	Ø20	45	0.10
068874	BRUSH	Circle	1/8 NPT	Ø15	10 to 80	50 to 176	Nylon	Ø20	20	0.04

## Support for brushes

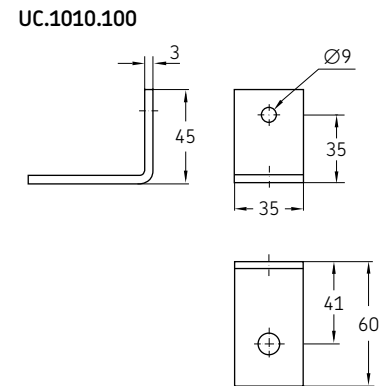
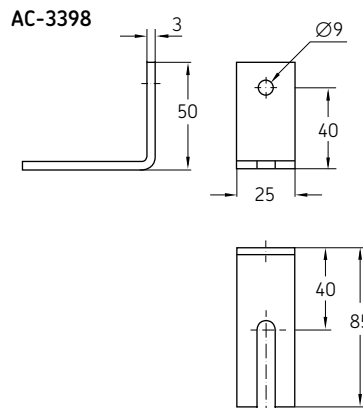
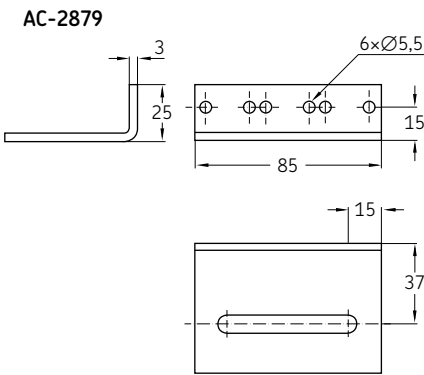

Order number	Designation	Suitable for brush	Temperature		Material
			°C	°F	
AC-2879	SUPPRT FOR BRUSH	UC-1066-01, -02, -06, -14	10 to 80	50 to 176	Steel
AC-3398	SUPPRT FOR BRUSH	UC-1066-04, -05, -10	10 to 80	50 to 176	Steel
UC.1010.100	SUPPRT FOR BRUSH	UC-1066-03	10 to 80	50 to 176	Steel



## Description

The tools shown in the following chapter considerably improve and professionalize assembly, maintenance and testing work on lubrication systems.

- Hand-operated bending tools are available for bending steel pipes in the outer diameters of 4, 6, 8, 10 mm; machine-operated bending devices should be used for larger diameters or quantities
- Claw groove tool can be used to cut the metal pipe to length in one step and to produce the exact geometric shape of the claw groove; a claw groove is necessary for the three O-ring connection fittings
- The hand lever grease gun can be optimally used for functional testing and pressure testing of small central lubrication systems (preferably progressive systems) and progressive metering devices; it is equipped with:
  - High-pressure hose 1 m long
  - Glycerin damped manometer 0–400 bar, 63 mm diameter
  - Union nut and cutting ring for connection to cutting ring fittings for pipe  $\varnothing$  6 mm

## Features and benefits

- Simple and proven design for use with all lubrication systems
- Manual tools, no additional energy source required
- Professional tools to achieve the right quality result

## Applications

- Lubrication system installation
- Lubrication system startup
- Lubrication system maintenance



# Pipe cutter

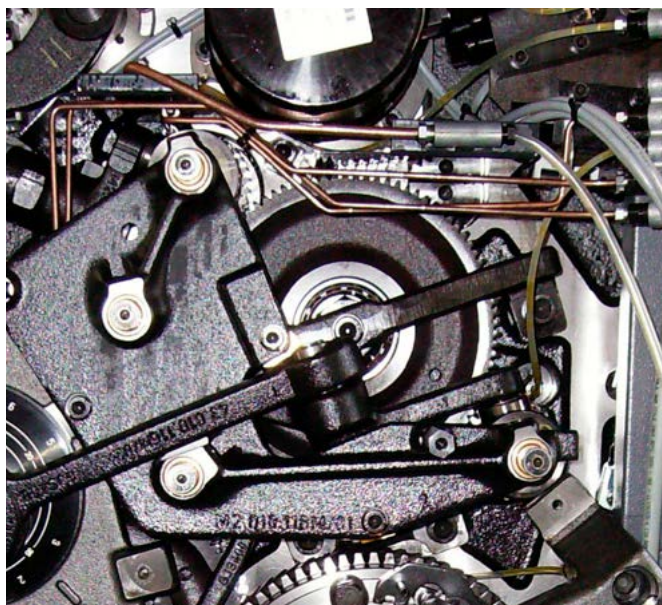

## Description

This manual pipe cutter is particularly suitable for pipes made of copper, brass, light metal and hard plastic, as well as for steel and stainless steel pipes with outside diameters from 3 to 35 mm and a maximum cutting depth of 2.5 mm.

## Features and benefits

- Optimal hold of the tube when cutting with two guide rollers
- Combines accuracy with ease of use
- Optimal size, light weight

## Applications

- Metal and plastic forming machinery
- Construction machinery
- Agriculture, automation
- Printing

### Technical data

Function	manual tube cutter
Material	steel, metal, plastic
Dimensions	145 x 58 x 45 mm 5.70 x 2.28 x 1.77 in

### Order information

Order number	Designation	Tube		
		Weight		
		Ø mm	g	lb
223-10540-1	STEEL PIPE CUTTER	3 - 35	356	0.78
223-10540-2	CUTTING COG SR153	3 - 35	6	0.01

## Tools

## Claw groove tool



## Description

The manual claw groove tool is suitable for hardened copper, brass, steel and stainless steel tubes with diameters of 4, 6, 8 and 10 mm. It allows the creation of claw grooves on metal pipes that are needed for use with SKF quick connectors.

## Features and benefits

- One compact tool for both cutting and grooving
- Combines accuracy with ease of use
- Optimal size, light weight

## Applications

- Metal and plastic forming machinery
- Construction machinery
- Agriculture, automation
- Printing

## Claw grooves

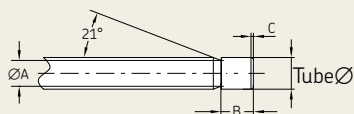

For the use of SKF quick connector fittings, a claw groove is required at the end of the pipe.



## Technical data

Function	manual claw groove tool
Material	steel, metal, plastic
Dimensions	154 × 50 × 50 mm 6.06 × 1.96 × 1.96 in

## Order information

Order number	Designation	Tube	Weight	
		$\varnothing$ mm	g	lb
<b>169-000-336</b>	Pipe cutter 4 mm	4	345	0.76
<b>169-000-337</b>	Pipe cutter 6 mm	6	344	0.76
<b>169-000-338</b>	Pipe cutter 8 mm	8	349	0.77
<b>844-330-006</b>	Cutting ring 4 mm	4	20	0.044
<b>844-330-007</b>	Cutting ring 6 mm	6	21	0.046
<b>844-330-007</b>	Cutting ring 8 mm	8	21	0.046

## Claw groove information

Tube	A	B	C
$\varnothing$ mm	mm	mm	mm
4	3,1	5	0,3 ... 0,7
6	4,9	6,2	0,4 ... 0,9
8	6,9	6,2	0,5 ... 0,9

# Tube bender



## Description

The easy-to-use manual tube bender is designed for pipe diameters of 6, 8 and 10 mm and has a bending radius range from 1-180° with a visible, marked scale featuring 15° steps. The bender is suitable for use with hardened copper, steel and stainless steel tubes.

## Features and benefits

- Designed for bending hardened copper, steel and stainless steel
- Provides measurements in inches and millimeters
- Combines accuracy with ease of use
- Optimal size, light weight
- Includes oil-absorbing shoe

## Applications

- Metal and plastic forming machinery
- Construction machinery
- Textile machinery
- Agriculture
- Automation
- Printing

## Technical data

Function	manual tube bender
Material	steel, metal, plastic
Bending radius	1-180°
Scale	15° steps
Length	260-370 mm 10.23-14.56 in

## Order information

Order number	Designation	Tube			Weight
		Ø mm	kg	lb	
223-13700-8	HAND-BENDING MACHINE	6	0,7	1.54	
223-13700-9	HAND-BENDING MACHINE	8	1,3	2.86	
223-13700-7	HAND-BENDING MACHINE	10	1,18	2.60	

# Tube bending fix



## Description

Designed for installation on a workbench, the manual tube bending fix is suitable for hardened copper, steel and stainless steel tubes with diameters of 4, 6, 8 and 10 mm. Its bending radius range is 1-180°.

## Features and benefits

- One compact tool for workbench assembly with exchangeable bending disks
- Combines accuracy with ease of use
- Optimal size, light weight

## Applications

- Metal and plastic forming machinery
- Construction machinery
- Textile machinery
- Agriculture
- Automation
- Printing

## Technical data

Function	manual tube bending fix
Material	steel, metal, plastic
Bending radius	1-270°

## Order information

Order number	Designation	Tube	Weight	
			kg	lb
		Ø mm		
<b>248-803.20</b>	Tube bending fix	4, 6, 8, 10	1,53	3.37
<b>248-803.17</b>	Bending disk	12 (special grooved disk) <sup>1)</sup>	0,378	0.83
<b>248-803.16</b>	Bending disk	4 (retro fitting set) <sup>2)</sup>	0,093	0.21

<sup>1)</sup> To bend pipes with 12 mm diameter, the special grooved disk 248-803.17 must be ordered in addition to pipe bending device 248-803.20.

<sup>2)</sup> Retro fitting set with grooved disk for older pipe bending devices 248-803.20.

# Tube cutter



## Description

This manual tube cutter is particularly suitable for tubes and hoses made of plastic and rubber, including tubes with thin metal layers. It cuts tubes with outside diameters up to 12,5 mm.

## Features and benefits

- Combines accuracy with ease of use
- Highly resistant against stress and flexural vibrations
- Small size, light weight

## Applications

- Metal and plastic forming machinery
- Construction machinery
- General industry
- Agriculture
- Printing

### Technical data

Function	manual hose cutter
Material	steel, metal
Dimensions	175 × 115 × 10 mm 6.88 × 4.52 × 0.39 in

### Order information

Order number	Designation	Tube
		Ø mm
226-12508-5	TUBE CUTTER	1-12,5
226-13095-7	TUBE CUTTER REPLACEMENT BLADES	1-12,5

## Tools

# Grease pump set for pressure and function check



### Description

This manual grease pump set for pressure and function check is a perfect tool for lubrication system installation, maintenance or troubleshooting existing systems. Its integrated pressure gauge, hose and fitting enable accurate system function check and help to identify system leaks as well as system blockages. The set includes two different connection options: a hydraulic coupler for grease nipple, and a fitting for connection of tube  $\varnothing 6$  mm.

### Features and benefits

- Combines accuracy with ease of use
- Set contains a wide range of fittings
- Robust and reliable tool
- Small size, light weight

### Applications

- Metal and plastic forming machinery
- Construction machinery
- General industry
- Agriculture
- Printing

### Technical data

Function	grease pump set for pressure and function check
Connections	hydraulic coupler for grease nipple, or fitting for connection of tube $\varnothing 6$ mm
Material	steel, metal

### Order information

Order number	Designation
--------------	-------------

<b>604-36879-1</b>	<b>PRESSURE AND FUNCTION TESTING SET</b>
--------------------	--

# Drum plug wrench



## Description

The drum plug wrench was developed to simplify the opening and closing of caps and plugs on fluid drums. The model 5841 wrench eliminates the need for cumbersome makeshift tools, such as screwdrivers and hammers. Constructed of safe, non-sparking cast aluminum, the drum plug wrench features a comfortable, textured grip. This cost-effective wrench is suitable for agriculture, construction, industrial, fleet maintenance and vehicle service applications – anywhere that fluid drums are used. It is compatible with standard metal and plastic caps or plugs on 60 l (16 gal) and 200 l (55 gal) drums.

## Features and benefits

- Suitable for common cap types – both plastic and metal
- Non-sparking, non-corrosive aluminum construction
- Saves time and effort when loosening and tightening plugs and caps
- Fits large and small caps
- Cost-effective solution
- Simple to use

## Applications

- Caps or plugs on 60 l (16 gal) and 200 l (55 gal) drums

### Technical data

Function	drum plug wrench
Application	60 l (16 gal) and 200 l (55 gal) drums
Material	aluminum
Wrench	3/4

### Order information

Order number	Designation
--------------	-------------

<b>005841</b>	<b>DRUM PLUG WRENCH</b>
---------------	-------------------------

# Socket wrench insert for elbows



## Description

This socket wrench insert for elbow fitting mounting allows quick and clean system installation work, especially in machines or in facilities where lubrication lines have to run around many corners and barriers.

## Features and benefits

- Combines accuracy with ease of use
- Highly resistant against stress and flexural vibrations
- Small size, light weight

## Applications

- Metal and plastic forming machinery
- Construction machinery
- General industry
- Agriculture
- Printing

### Technical data

Function	socket wrench insert
Application	elbows with max. width of 11 mm
Material	tool steel
Wrench	1/4
Dimensions	Ø24 mm, height 20 mm

### Order information

Order number	Designation
--------------	-------------

<b>917-877</b>	<b>SOCKET WRENCH INSERT FOR ELBOWS</b>
----------------	--



# Mounting stud for hose couplings



## Description

The mounting stud is an important tool for the self-assembly of threaded joints of high-pressure hoses. With the aid of the stud, it is possible to mount the threaded sleeve in the correct position in the high-pressure hose. This is important because incorrectly mounted sleeves can cause the hose to burst or couplings not to seal.

## Features and benefits

- Simple mounting without complex measuring with caliper
- Avoids malfunctions in the central lubrication system due to blocked or burst hose lines
- Avoids errors during hose assembly

## Applications

- Hose mounting for nominal diameter 6 mm

### Technical data

Function	mounting stud
Hose type	ND 6 mm
Immersion depth	11 mm
Material	galvanized steel
Weight	20 g; 0.05 lbs
Dimensions	Ø10 mm, Ø6 mm, 40 mm

### Order information

Order number    Designation

---



---

**432-23077-1**    MOUNTING STUD

## Manual grease guns



### Description

The right lubricant has to be supplied in the right quantity at the right time in the right quality to the right lubrication point. Particularly contamination during the transfer process, applying too much or too little lubricant and using the wrong lubricant for a lubrication point are common problems and can easily be prevented. The SKF manual lubrication tools are specifically designed and selected to support these processes.

### Features and benefits

- Avoid mistakes during manual lubrication with tools that are designed to support the “right” lubrication
- Select the best products for your needs from a wide product portfolio for storage, handling, dosing, labelling, analyzing and applying lubricants

### Applications

- Agriculture and forestry industry
- Construction machinery
- Pulp and paper industry
- Renewables industry
- Oil and gas industry
- On-road vehicles
- Heavy industry
- Etc.

## Manual grease guns

# Manual grease filler guns



### Description

The manual cartridge grease gun is ideal for agricultural, industrial and construction industries and for private use. It can be utilized to lubricate directly or as filler pump for automatic lubrication systems. The tool is designed for rough treatment on the job with a cast iron pump head, precision fit plunger and extra heavy follower spring.

### Features and benefits

- For use with cartridges and bulk grease
- Knurled body for firm and safe grip
- High-output setting delivers twice the grease per stroke
- High or low pressure for light- or heavy-duty greasing action
- Extension swivels 360° for hard-to-reach fittings
- Plated barrel, head and handle

### Applications

- General mechanic and plant engineering
- Agriculture, construction, automotive, trucking
- Heavy equipment
- Wind energy
- General industry

### Technical data

Function	manually operated cartridge grease gun
Delivery rate	max. 284 g/min; 10 oz/min
Cartridge capacity	420 ml; 14.2 fl oz
Operating temperature	-18 to 50 °C; 0 to 122 °F
Lubricant	grease up to NLGI 2
Material	steel, metal, plastic

### Order information

Order number	Designation	Operation pressure max.		Weight	
		bar	psi	kg	lb
001013	LEVER GUN	275	4 000	2,09	4.61
001142	LEVER GUN	400	5 800	1,85	4.08
001133	PISTOL GUN	414	6 000	1,62	3.57

## Manual grease guns

## PowerLuber

Model 1260

Model 1880

Model 1890



## Description

PowerLuber Li-ion grease gun family is designed to make quick work of lubrication tasks. It contains the rugged simplicity of the 12V, single-speed model, the speed and versatility of the durable 20V, high ratio, two speed design and the advanced technology of the 20V with LCD.

## Features and benefits

- Flex hose that comes with anti-kink spring guards on each end and is the ideal size for most lubrication tasks
- Integrated vent valve purges trapped air to help assure easy prime
- The filler nipple facilitates a quick, clean refill for those who prefer to bulk fill their barrel
- Lithium-ion technology is powerful and efficient, delivering an even flow of energy
- LCD display version shows battery charge and grease output in both grams and ounces

## Applications

- General mechanic and plant engineering
- Agriculture, construction, automotive, trucking
- Heavy equipment
- Wind energy
- General industry

## Technical data

Function	battery-operated grease gun
Operating power	12V or 20 V
Operating pressure	max. 690 bar; 10 000 psi
Delivery rate	max. 284 g/min; 10 oz/min
Reservoir capacity	411 g; 14.5 oz
Operating temperature	-18 to 50 °C; 0 to 122 °F
Rated current	5.0 A
Lubricant	grease up to NLGI 2
Material	steel, metal, plastic
Weight	3,4 kg; 7.5 lb

## Order information

Order number	Description	Approval
<b>1890</b>	20V Li-ion high-ratio dual output grease gun with single battery	UL
<b>1886</b>	20V Li-ion high-ratio dual output grease gun with single battery, charger and carrying case	UL
<b>1886-E</b>	20V Li-ion high-ratio dual output grease gun with single battery, charger and carrying case	CE
<b>1880</b>	20V Li-ion 2-speed grease gun with multi-funcion LED and single battery	UL
<b>1882</b>	20V Li-ion 2-speed grease gun with multi-funcion LED and single battery, charger and carrying case	UL
<b>1882-E</b>	20V Li-ion 2-speed grease gun with multi-funcion LED and single battery, charger and carrying case	CE
<b>1871</b>	20V Li-ion battery, 2,5 Ah	UL, CE
<b>1872</b>	20V Li-ion battery, 4,0 Ah	UL, CE
<b>1260</b>	12V Li-ion single-speed grease gun with single battery	UL
<b>1262</b>	12V Li-ion single-speed grease gun with single battery, charger and carrying case	UL
<b>1262-E</b>	12V Li-ion single-speed grease gun with single battery, charger and carrying case	CE

# Manual grease guns

## PowerLuber

**20V Li-ion PowerLuber**  
High-ratio, dual-output design for low- or high-volume lubrication points



Model 1890

**20V Li-ion PowerLuber**  
Two-speed grease gun with multi-function LCD identifying output quantity, battery charge and motor speed



Model 1880

**12V Li-ion PowerLuber**  
Single-speed grease gun



Model 1260



Model 1886 / 1886-E



Model 1882 / 1882-E



Model 1262



Model 1888



Model 1884



Model 1264



Full range of high-pressure hoses for all Lincoln PowerLuber models

- Model 1218 18 in. 46 cm
- Model 1224 24 in. 61 cm
- Model 1230 <sup>2)</sup> 30 in. 76 cm
- Model 1236 <sup>3)</sup> 36 in. 91 cm
- Model 1248HP <sup>4)</sup> 48 in. 122 cm (new)

Included with the PowerLuber

- <sup>1)</sup> Standard on all PowerLuber models
- <sup>2)</sup> Standard on the 12V models
- <sup>3)</sup> Standard on the 20V models 1882 and 1884
- <sup>4)</sup> Standard on the 20V models 1886 and 1888 (new)



Grease coupler <sup>1)</sup>  
Model 5852



Heavy-duty grease coupler  
Model 5845

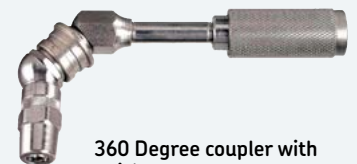

360 Degree coupler with quick-connect  
Model 5849



Carrying strap  
Model 1414



Lever-action coupler  
Model 5900

## Refill pumps



### Description

Filling pumps make it easier to top up lubricants in reservoirs of automatic lubrication pumps. By using original barrels, hoses and couplings, it is ensured that no dirt gets into the reservoir during the filling process. Contaminated lubricants that enter the reservoir during manual filling via the open reservoir lid are the greatest risk of malfunctions in a centralized lubrication system.

Depending on the desired degree of automation, the filling pumps can be supplied with manual, compressed air or electric drive.

For longer transport distances, the use of a filling pump on a trolley is recommended.

### Features and benefits

- Improved maintenance of all lubrication systems
- Easy-to-use, application-optimized product design
- Quick and professional refilling with contamination prevention, compared to manual grease refilling
- Optimized consumption of refilling barrel lubricants due to use of perfectly suited barrel follower plates
- Wide range of filling pumps for all common reservoir sizes

### Applications

- General mechanic and plant engineering
- Agriculture and forestry industry
- Construction machinery
- Pulp and paper industry
- Renewables industry
- Oil and gas industry
- On-road vehicles
- Heavy industry
- Etc.

## Refill pumps

# Filler cylinder



### Description

Lubricant outlets of automatic lubrication system pumps can, as an option, be equipped with one suitable filler socket in order to fill the unit using a filling cylinder (cartridge). A filler cylinder is only recommended for systems with low lubricant consumption and reservoir sizes up to 2 kg.

### Features and benefits

- Robust and sustainable manual filler pump
- Knurled body for firm and safe grip
- Easy to use

### Applications

- General mechanic and plant engineering
- Agriculture, construction, automotive, trucking
- General industry
- Heavy equipment
- Wind energy

### Technical data

Function	manually operated cartridge filler cylinder
Reservoir capacity	420 ml; 14.2 fl oz
Operating temperature	-18 to 50 °C; 0 to 122 °F
Lubricant	grease up to NLGI 2
Material	steel, metal, plastic

### Order information

Order number	Designation	Thread
		mm
Filling cylinder and filling connection for pumps with inlet thread M20x1		
<b>169-000-171</b>	FILLER CYLINDER	–
<b>169-000-174</b>	FILL CONNECTION	M20x1,5
Filling cylinder kit for pumps with inlet thread M22x1		
<b>638-37548-1</b>	KIT:FILLING PUMP,HAND-OPER. 90 DEGREE	M22x1,5
<b>638-37549-2</b>	KIT:FILLING PUMP,HAND-OPER.	M22x1,5

# Manual and pneumatic filling pumps 169



## Description

The 169 series of filling pumps is available in manual or pneumatic models that are suitable for barrel sizes of 15, 20, 25 and 50 kg. The pumps are offered in stationary or mobile versions.

## Features and benefits

- Easy and cost-efficient filling of pump reservoirs
- No contamination of the lubricant during the filling process
- Steel pump with guided grease follower piston
- Centering cover that positions the pump centrally in the barrel and ensures optimum residual emptying

## Applications

- Construction and agriculture vehicles
- Production plants

### Technical data

Function	filling pump
Design	manually operated filling pump
Delivery rate	max. 100 g/stroke; 10 oz/stroke
Design	pneumatically operated filling pump
Delivery rate	max. 1 800 g/min; 3.97 lbs/min
Ratio	1 : 3
Operating pressure	max. 24 bar; max. 348 psi
Air pressure	max. 8 bar; max. max. 116 psi
Barrel capacities	15, 20, 25 and 50 kg
Operating temperature	-10 to +40 °C; 14 to 104 °F
Lubricant	fluid grease and grease up to NLGI 2
Coupling	acc. to ISO 241 B DN6 R 1/4
Hose length	2 m; 6.5 ft
Material	steel, metal, plastic
Dimensions	max. 550 x 550 x 950 max. 21.65 x 21.65 x 37.4

### NOTE

For further technical information, technical drawings, accessories, spare parts or product function descriptions, see the following publication available on [SKF.com/lubrication](http://SKF.com/lubrication)



## Refill pumps

# Manual and pneumatic filling pumps 169

### Order information

Order number	Designation	Drum	Inner diameter		Lubricant	Delivery rate per stroke		Weight	
			kg	mm		in	cm <sup>3</sup>	in <sup>3</sup>	kg
<b>169-000-004</b>	MANUAL FILLING PUMP 15L,STATIONARY	15	267	10.5	NLGI 1/2	4	0.25	4,383	9.66
<b>169-000-012</b>	MANUAL FILLING PUMP 10L,STATIONARY	10	236	9.3	NLGI 1/2	25	1.53	4,68	10.32
<b>169-000-016</b>	MANUAL FILLING PUMP 20L,STATIONARY	20	290	11.4	NLGI 1/2	25	1.53	5,12	11.30
<b>169-000-084</b>	MANUAL FILLING PUMP 25L,STATIONARY	25	350 <sup>1)</sup>	13.8 <sup>1)</sup>	00/000	250	15.3	4	8.82
<b>169-000-042</b>	MANUAL FILLING PUMP 25L,MOBILE	25	300-335	11.2-13.2	NLGI 000-2	45	2.7	16,8	37.04
<b>169-000-054</b>	MANUAL FILLING PUMP 50L,MOBILE	50	355-387	14-15.2	NLGI 000-2	45	2.7	10	22.05
<b>169-000-342</b>	MANUAL FILLING PUMP 25L,STATIONARY	25	300-335	11.2-13.2	NLGI 000-2	45	2.7	6,38	14.06
<b>169-000-018</b>	FILLING PUMP, PNEUM. 25L, MOBILE	25	300-335	11.2-13.2	NLGI 1/2	45	2.7	16,8	37.04

<sup>1)</sup> max. outer diameter

# Compact grease transfer pump GTP-C



## Description

To use the GTP-C, simply turn on the main switch located on the terminal box. The function status is shown by two LEDs, with green indicating power supply and yellow indicating the pump's operational readiness. The GTP-C will deliver grease continuously while the button on the wired remote control is pressed. The grease in the drum or pail is drawn below the follower plate and fed by the pump. When the follower plate reaches the bottom of the drum, it activates an empty signal switch that automatically shuts off the pump. Replacing the empty grease drum is simplified by opening the vent.

## Features and benefits

- Purely electric drive
- Filling hose with quick-release coupling or connection with M30x2 thread
- High delivery volume up to 1 100 cm<sup>3</sup>/min (0.29 gal/min)
- Powerful performance with no air connection required
- Fast filling even at low temperatures
- Time- and effort-saving alternative to manual filling
- Easy-to-use in mobile applications

## Applications

- Wind energy
- Service and maintenance trucks
- Mining and construction vehicles
- General mechanical and plant engineering

## Technical data

Function	electrically operated gerotor pump
Delivery rate	max. 1 100 cm <sup>3</sup> /min; 67 in <sup>3</sup> /min
Barrel capacities	5 gal. (only 799-000-3161) 25 kg / 30 l 50 kg / 60 l 180 kg / 216 l
Operating temperature	-10 to +50 °C; 14 to 122 °F
Lubricant	grease up to NLGI 2
Outlet fitting	quick-release coupling or connection with M30x2 thread
Rated delivery pressure	max. 100 bar; 1450 psi
Material	steel, metal, plastic
System voltage	230 V AC/50 or 120V AC/60 Hz
Motor power	0,37 kW
Protection class	IP54
Insulation class	F
Electrical connection	grounded plug, 3 m (9.8 ft) cable - motor protection via circuit breaker
Activation	wired remote control (5/10/15 m)
Dimensions (pump only)	250 x 597 mm; 9.13 x 26.38 in

## NOTE

For further technical information, technical drawings, accessories, spare parts or product function descriptions, see the following publication available on [SKF.com/lubrication](http://SKF.com/lubrication):

**14970 EN; 951-181-023-EN**

**Order information**

Order number	Description	Approval
<b>799-000-3161</b>	Filling pump mounted on frame with follower plate in transport pail, 120 V AC/60 Hz	UL
<b>799-000-3109</b>	Filling pump mounted on frame with follower plate in transport pail, 230 V AC/50 Hz, 25 kg reservoir	CE
<b>799-000-3119</b>	Filling pump mounted on frame with follower plate in transport pail, 230 V AC/50 Hz, 50 kg reservoir	CE
<b>799-000-3118</b>	Filling pump mounted on frame with follower plate in transport pail, 230 V AC/50 Hz, 180 kg reservoir	CE

## Refill pumps

# Grease transfer pump GTP



### Description

Pump frames for grease drum sizes of 50 to 200 kg are available on request. The pump is ready for operation after switching on the main switch on the terminal box. The function status is shown by 2 LEDs. Green indicates the power supply and yellow the pump's operational readiness. The pump delivers grease.

### Features and benefits

- Powerful even where only power connection (no air connection) is available
- Time- and effort-saving alternative to manual filling
- Filling hose with quick-release coupling or connection with M30x2 thread
- High delivery volume up to 2 500 cm<sup>3</sup>/min (152 in<sup>3</sup>/min)
- Fast filling even at low temperatures
- Easy-to-use in mobile applications
- For pressure up to 100 bar

### Applications

- General mechanical and plant engineering
- Construction and agriculture
- Wind energy
- Vehicles
- Railway

### Technical data

Function	electrically operated gerotor pump
Delivery rate	max. 2 500 cm <sup>3</sup> /min; 152 in <sup>3</sup> /min
Barrel capacities	25 kg/30 l (further on request)
Operating temperature	-10 to +50 °C; 14 to 122 °F
Lubricant	grease up to NLGI 2
Outlet fitting	quick-release coupling or connection with M30x2 thread
Rated delivery pressure	max. 100 bar; 1 450 psi
Material	steel, metal, plastic
System voltage	230 V AC / 50 Hz
Motor power	0,75 kW
Protection class	IP54
Insulation class	F
Electrical connection	grounded plug, 3 m cable - motor protection via circuit breaker
Activation	wired remote control (5/10/15 m)
Dimensions (pump only)	250 x 993 mm; 6.8 x 39 in

### NOTE

For further technical information, technical drawings, accessories, spare parts or product function descriptions, see the following publication available on [SKF.com/lubrication](http://SKF.com/lubrication):

**14657 EN; 810-53479-EN**

## Order information

Order number	Description	Approval
24-1560-3576	Filling pump with transport bracket and plug and socket coupling	CE
24-1560-3595	Filling pump <b>without</b> transport bracket and plug and socket coupling	CE
24-1722-2557	Pump frame with follower plate for grease drums 25 kg/30 l with empty signal	CE
24-1722-2559	Pump frame with follower plate for grease drums 25 kg/30 l, without empty signal	CE

## Refill pumps

# Electric filling pump EFP



### Description

The EFP electric grease filling pump is a piston pump for grease drum sizes from 16 to 25 kg. The delivery stroke is generated at the lower end of the intake tube by a delivery piston that is controlled by an electrically driven eccentric shaft. The pump is activated using an ON/OFF switch attached to the terminal box.

### Features and benefits

- Suitable for pressures up to 250 bar
- Suitable for oil, fluid grease and grease
- Integrated automatic shut-off function for use with grease guns

### Applications

- Wind energy
- Stationary and mobile vehicles

### Technical data

Function	electrically operated piston pump
Delivery rate	max. 400 cm <sup>3</sup> /min; 24 in <sup>3</sup> /min
Barrel capacities	16 and 25 kg
Operating temperature	-10 to +60 °C; 14 to 140 °F
Lubricant	oil, fluid grease and grease up to NLGI 2
Outlet fitting	G 1/4
Automatic shut-off, fixed	250 bar
Pressure regulating valve, fixed	300 bar
Restart after pressure relief	< 150 bar
Material	steel, metal, plastic
System voltage	230 V AC/50 to 60 Hz
Motor power	370 W
Protection class	IP54
Insulation class	F
Intake current	2,73 A
Electrical connection	grounded plug, 3 m cable - motor protection via circuit breaker
Dimensions (pump only)	550 x 900 mm; 21.7 x 35.4 in

### NOTE

For further technical information, technical drawings, accessories, spare parts or product function descriptions, see the following publication available on

SKF.com/lubrication:

**13149 EN; 951-180-061-EN**

## Refill pumps

# Electric filling pump EFP

### Order information

Order number	Designation	Weight	
		kg	lb
<b>24-1560-3577</b>	EL. BARREL PUMP EFP	34,5	76.07
<b>24-1560-3578</b>	EL. BARREL PUMP EFP WITH SIGNAL INPUT	34,9	76.95
<b>24-1868-4334</b>	HIGH-PRESSURE HOSE, MAX. 275 BAR, 5 M	–	–
<b>412-423W</b>	SCREW UNION G1/4A 412-423W	–	–
<b>995-001-500</b>	COUPLING BELL G1/4	–	–
<b>995-000-705</b>	COUPLING PLUG G1/4	–	–
<b>169-000-031</b>	GREASE GUN	–	–

### Accessories for EFP

Order number	Designation	Drums	Weight	
			kg	kg lb
<b>24-1722-2551</b>	CARRYING FRAME WITH HANDLE AND WHEELS	16/25	16,6	36.60
<b>24-1722-2552</b>	CARRYING FRAME WITH WHEELS	16/25	15	33.08
<b>24-1952-2034</b>	FOLLOWER PLATE Ø 265-285	16/25	0,7	1.54
<b>24-1952-2035</b>	FOLLOWER PLATE Ø 285-305	16/25	1	2.21
<b>24-1952-2036</b>	FOLLOWER PLATE Ø 305-350	16/25	1,5	3.31

# Cross reference list

Historical order number	SKF Lincoln order number	Historical order number	SKF Lincoln order number
226-12490-3	898-610-000	410-323	223-14304-2
226-12557-1	941-206-104	410-403	223-14129-4
226-12557-2	941-209-104	410-403W	223-12272-9
226-12557-7	941-210-104	410-403W-S3	223-14420-7
226-13095-1	898-710-001	410-404	223-12483-8
226-13095-6	179-990-186	410-405W	223-13048-5
401-013-111	222-12599-9	410-407	223-13057-5
401-016-132	222-12521-2	410-409	223-12409-9
401-016-191	222-12578-5	410-410	223-12531-2
401-021-111	222-13678-4	410-410-S3	223-13615-6
404-301	223-14083-3	410-411	223-13028-2
404-302	223-13032-1	410-413W	223-14214-4
404-403	223-13069-1	410-416	223-12368-8
404-403W	223-12270-8	410-425	223-12485-2
404-404	223-12531-8	410-433W	223-10313-7
404-405W	223-13021-4	410-443-S3	223-14420-4
404-413	223-12271-8	410-463	223-10313-2
404-425	223-13069-2	412-301	223-12296-1
406-301	223-12295-3	412-302	223-12373-2
406-302	223-12373-9	412-403W	223-12360-8
406-302-S3	223-14082-5	412-411	223-12481-8
406-303	223-14234-7	412-412	223-13732-8
406-323	223-13766-9	412-416	223-13698-4
406-331	223-12295-2	412-423W	223-12477-9
406-332	223-12374-9	415-301	223-12296-9
406-332-S3	223-13638-2	415-302	223-12374-8
406-333	223-14129-1	415-403W	223-12361-9
406-403	223-12571-2	415-405W	223-13021-7
406-403-S3	223-14184-5	415-407	223-12563-2
406-403W	223-13016-3	415-409	223-12409-8
406-403W-S3	223-13658-2	415-415	223-12531-6
406-404	223-12483-2	415-415-S3	223-12454-8
406-405	223-12485-8	415-416	223-12564-2
406-405W	223-13048-1	415-433W	223-13621-8
406-406	223-12482-9	418-301	223-12583-1
406-407	223-12484-2	418-302	223-12374-7
406-409	223-13050-4	418-403W	223-13766-1
406-411	223-12481-4	418-403W-S3	223-14420-8
406-413W	223-12477-1	418-416	223-12564-8
406-413W-S3	223-13614-7	418-418	223-13732-4
406-415W	223-12380-6	422-407	223-13057-4
406-416	223-12368-4	428-403W	223-13610-9
406-423	223-12271-7	428-413W	223-14214-9
406-423-S3	223-13658-5	441-008-511	223-13021-1
406-423W	223-12270-7	441-008-511-S3	223-13715-1
406-423W-S3	223-13614-9	471-110-163	223-13028-4
406-425	223-13021-3	471-112-162	223-12286-8
406-433	223-13023-1	443-215-001	223-12562-2
406-433-S3	223-13658-6	443-306-341	223-14171-1
406-435	223-13023-3	443-308-351	223-14102-3
406-435-S3	223-13677-2	443-406-061	223-14190-6
406-443	223-12533-9	443-408-081	223-14190-7
406-443-S3	223-13658-7	443-410-101	223-13040-9
406-445	223-13023-2	443-412-121	223-13761-5
406-445-S3	223-13677-4	443-415-151	223-14190-5
406-446	223-14181-3	445-516-081	223-12284-7
406-463W	223-13766-6	445-519-041	223-13629-1
408-301	223-12295-6	445-519-061	223-12479-5
408-302	223-13032-4	445-529-041	223-12480-2
408-403	223-12361-6	445-531-061	223-12369-7
408-403W	223-12477-6	445-531-062	223-12480-7
408-405	223-12362-8	445-713-151	445-713-152
408-405W	223-14240-5	445-739-151	445-739-152
408-407	223-12484-6	445-808-351	223-13040-1
408-408	223-12531-9	445-810-371	223-14189-1
408-408-S3	223-13615-3	460-706-001	223-10297-5
408-409	223-12409-6	460-710-001	223-10297-6
408-411	223-12481-6	466-411-001	223-10530-4
408-413W	223-10080-3	466-413-001	223-13702-7
408-416	223-12368-6	466-416-001	223-13702-1
408-423W	223-12270-9	466-418-001	223-13702-6
408-423W-S3	223-13614-9	471-106-163	223-13655-1
408-425	223-12362-4	471-110-163	223-13655-7
410-301	223-12295-8	471-112-163	223-14268-4
410-302	223-13032-6	504-410	223-12542-2



## Cross reference list

Historical order number	SKF Lincoln order number	Historical order number	SKF Lincoln order number
506-410	223-13705-5	96-6202-0058	223-12533-6
506-412	223-13622-3	96-6904-0058	223-12563-5
506-413	223-10986-1	96-7004-0058	223-13629-1
506-512-VS	506-142-VS	96-7006-0058	223-12479-9
508-410	223-13024-4	96-7008-0058	223-12479-8
508-412	223-13622-7	96-7104-0158	223-12480-8
508-413	223-13024-8	96-7920-0058	223-12285-7
510-412	223-12542-7	99-0204-0058	223-13658-9
96-0203-0058	223-10814-2	99-0215-0058	223-13715-9
96-0204-0058	223-12477-8	99-0217-0058	223-13715-6
96-0222-0058	223-13016-2	99-0228-0058	223-14184-2
96-0223-0058	223-13749-3	99-2712-0058	223-13639-9
96-0308-0060	223-10889-2	99-5604-0058	223-13638-6
96-0328-0058	223-14214-8	99-5612-0058	223-14082-3
96-0408-0058	223-12483-5	99-5704-0058	223-13639-5
96-0506-0060	223-10307-2	DIN7513-BM5x10	206-12124-3
96-0510-0060	223-13033-2	DIN7513-BM6x16	206-12125-4
96-0706-0060	223-13693-4	DIN912-M4x12-A4	201-13741-1
96-0708-0060	223-13693-6	DIN912-M4x20-8.8	201-12015-5
96-0710-0060	223-13693-2	DIN912-M5x10-A2	201-13608-6
96-0722-0060	223-12273-2	DIN912-M6x16-8.8	201-12019-9
96-1108-0058	223-12477-2	DIN912-M6x25-8.8	201-12018-7
96-1110-0058	223-13016-4	DIN912-M6x60-8.8	201-12019-6
96-1111-0058	223-13016-9	DIN912-M8x16-8.8	201-12021-3
96-1112-0058	223-13016-7	DIN933-M10x40-8.8	200-12523-3
96-1113-0058	223-14129-3	DIN933-M5x12-8.8	200-13092-1
96-1116-0058	223-13621-1	DIN933-M6x16-8.8	200-13022-4
96-1117-0058	223-13749-5	DIN933-M6x20-8.8	200-13022-7
96-1120-0058	223-12359-6	DIN933-M6x25-8.8	200-13022-1
96-1121-0058	223-12360-6	DIN933-M8x20-8.8	200-12553-4
96-1508-0060	223-10670-3	DIN934-M5-8	207-12138-2
96-1511-0060	223-12582-5	DIN934-M6-8	207-12135-5
96-1523-0060	223-14293-2	DIN936-M14x1.5-5	207-12141-1
96-1532-0060	223-14152-2	DIN936-M16x1.5-5	207-12141-8
96-1533-0060	223-14293-4	DIN985-M12-8	207-12516-6
96-1545-0060	223-14293-8	DIN985-M3-6	207-12516-9
96-1610-0060	223-10688-1	DIN985-M8-6	207-12516-1
96-1612-0060	223-13054-4		
96-1622-0060	223-12287-8		
96-1623-0060	223-12288-2		
96-1643-0060	223-14293-1		
96-1653-0060	223-12577-2		
96-1654-0060	223-12580-2		
96-1656-0060	223-13759-7		
96-3101-0058	222-13678-2		
96-3105-0058	222-12578-9		
96-3106-0060	223-14189-6		
96-3109-0058	222-13678-8		
96-3110-0058	222-12521-8		
96-3111-0058	222-11053-1		
96-3112-0060	223-13785-8		
96-3113-0058	222-13678-3		
96-3115-0060	223-14189-7		
96-3116-0058	222-12521-5		
96-3117-0058	222-12521-6		
96-3118-0058	222-12521-4		
96-3120-0058	222-12578-4		
96-3121-0058	222-12578-8		
96-3122-0058	222-12578-3		
96-3125-0058	222-12599-3		
96-3127-0058	222-12047-8		
96-3128-0058	222-12047-4		
96-3131-0058	222-12599-5		
96-3132-0058	222-13670-1		
96-3134-0058	222-12599-6		
96-3208-0060	223-10374-3		
96-3210-0060	223-14189-5		
96-3212-0060	223-14189-9		
96-3216-0060	223-14189-2		
96-5608-0058	223-13032-3		
96-5610-0058	223-12374-6		
96-5708-0058	223-12295-5		
96-5710-0058	223-12295-9		
96-5909-0058	223-13621-6		
96-6002-0058	223-12533-5		

# Index

24-1207-2204.....	135	96-3118-0060 .....	63	106-35203-4 .....	105	169-110-020 .....	135
24-1560-3577.....	175	96-3122-0060 .....	63	106-35203-7.....	105	169-116-000.....	135
24-1560-3578.....	175	96-3129-0058 .....	76	106-35231-1.....	105	169-125-015.....	136
24-1722-2551.....	175	96-3133-0058 .....	76	106-35231-2.....	105	169-125-020 .....	135
24-1722-2552.....	175	96-3136-0058 .....	76	106-35231-3.....	105	169-140-001.....	136
24-1868-4334 .....	175	96-3137-0058 .....	76	106-35231-6.....	105	169-200-008 .....	34
24-1952-2034 .....	175	96-5208-0058-E0.....	58	106-35267-4.....	105	179-990-186.....	121
24-1952-2035 .....	175	96-5212-0058 .....	58	106-35292-1.....	105	200-10406-7 .....	121
24-1952-2036 .....	175	96-5215-0058 .....	58	106-35292-2.....	105	200-12007-6 .....	121
44-1755-2019.....	25	96-5315-0058 .....	58	111-35114-1 .....	112	200-12009-7 .....	121
44-1755-2029.....	73	96-5410-0058 .....	58	111-35306-5.....	103	200-12399-2 .....	121
96-0335-0058 .....	43	96-5416-0058 .....	58	112-35127-2.....	102	200-12523-3 .....	121
96-0342-0058 .....	43	96-5506-0058 .....	58	112-35127-5.....	102	200-12553-4 .....	121
96-0508-0060.....	53	96-5911-0058 .....	44	112-35127-7.....	102	200-12553-8 .....	121
96-0512-0060 .....	53	96-5912-0058 .....	44	112-35225-4.....	102	200-13017-5.....	121
96-0606-0060.....	53	96-5913-0058 .....	44	113-35075-2.....	103	200-13017-9.....	121
96-0608-0060.....	53	96-6112-0058 .....	51	113-35075-3.....	103	200-13022-1 .....	121
96-0712-0060 .....	53	96-6304-0058 .....	62	161-110-031+924.....	133	200-13022-4 .....	121
96-0715-0060 .....	53	96-6306-0058 .....	62	161-120-064+924 .....	133	200-13022-7 .....	121
96-0718-0060 .....	53	96-6308-0058 .....	62	161-212-054.....	130	200-13037-3.....	121
96-0806-0058.....	62	96-6404-0058 .....	62	161-600-036 .....	132	200-13092-1.....	121
96-0808-0058.....	62	96-6406-0058 .....	62	162-310-005 .....	141	201-12015-5.....	121
96-0810-0058.....	62	96-6408-0058 .....	62	169-000-004 .....	169	201-12018-7.....	121
96-0818-0058.....	62	96-7108-0058 .....	58	169-000-012 .....	169	201-12019-6.....	121
96-0906-0058.....	62	96-7808-0058 .....	57	169-000-016 .....	169	201-12019-9.....	121
96-1114-0058.....	44	96-7812-0058 .....	57	169-000-018 .....	169	201-12021-3.....	121
96-1206-0058 .....	43	96-7815-0058 .....	57	169-000-031 .....	175	201-13608-6 .....	121
96-1214-0058.....	43	96-7818-0058 .....	57	169-000-042 .....	169	201-13741-1 .....	121
96-1406-0060 .....	59	96-7822-0058 .....	57	169-000-054 .....	169	202-085-S .....	131
96-1408-0060 .....	59	96-7914-0058 .....	57	169-000-084 .....	169	202-175-30.....	127
96-1410-0060 .....	59	96-7916-0058 .....	57	169-000-171.....	167	202-275-2.....	127
96-1412-0058.....	51	96-8006-0058 .....	58	169-000-174.....	167	206-12124-3.....	121
96-1541-0060 .....	59	96-8008-0058 .....	58	169-000-336 .....	154	207-168-2.....	123
96-1542-0060 .....	59	96-8012-0058 .....	57	169-000-337 .....	154	207-168.U2 .....	123
96-1543-0060 .....	59	96-8014-0058 .....	57	169-000-338 .....	154	207-168.U7.....	123
96-1551-0060 .....	59	96-8016-0058 .....	57	169-000-342 .....	169	207-188-2.....	123
96-1556-0060 .....	59	96-8906-0058 .....	60	169-101-004.....	135	207-188.U11.....	123
96-1633-0060 .....	59	99-0222-0058 .....	45	169-101-607.....	136	213-870.....	147
96-1642-0060 .....	59	105-35025-5 .....	104	169-102-015.....	136	213-870F.....	147
96-1644-0060 .....	59	105-35134-1.....	104	169-102-020 .....	135	213-870.U1.....	147
96-1652-0060 .....	59	105-35134-3.....	104	169-102-506 .....	137	213-870.U2.....	147
96-1706-0058 .....	62	105-35134-4.....	104	169-104-008 .....	137	213-870.U2.....	147
96-1806-0058.....	62	105-35134-9.....	104	169-104-015.....	136	213-880.....	147
96-1808-0058.....	62	105-35183-3.....	104	169-104-020 .....	135	213-880.U1.....	147
96-2106-0058.....	52	105-35251-1.....	104	169-106-004 .....	137	213-930F.....	147
96-2118-0058 .....	52	105-35251-3.....	104	169-106-011.....	136	220-12238-3 .....	149
96-2122-0058 .....	52	105-35308-1 .....	104	169-106-015.....	136	222-10365-3 .....	76
96-3102-0058 .....	76	106-35203-1.....	105	169-106-020 .....	135	222-12047-2.....	76
96-3106-0058 .....	76	106-35203-2 .....	105	169-110-010.....	136	222-12047-4.....	76
96-3112-0058 .....	76	106-35203-3 .....	105	169-110-015.....	136	222-12047-8.....	76

# Index

222-12521-2.....	76	223-10550-2 .....	48	223-12296-9 .....	41	223-12454-8.....	46
222-12521-4.....	76	223-10550-6 .....	48	223-12359-6 .....	44	223-12455-1.....	49
222-12521-5.....	76	223-10550-8 .....	48	223-12360-6 .....	44	223-12455-2.....	49
222-12521-6.....	76	223-10563-5 .....	48	223-12360-8 .....	44	223-12455-5.....	49
222-12521-8.....	76	223-10563-6 .....	48	223-12361-6.....	43	223-12456-1.....	57
222-12578-3.....	76	223-10563-7 .....	48	223-12361-9.....	44	223-12456-6.....	57
222-12578-4.....	76	223-10563-8 .....	48	223-12362-4 .....	50	223-12456-7.....	57
222-12578-5.....	76	223-10670-3.....	59	223-12362-8 .....	50	223-12456-9.....	57
222-12578-8.....	76	223-10688-1 .....	59	223-12363-2 .....	46	223-12477-1.....	44
222-12578-9.....	76	223-10814-2.....	44	223-12363-6 .....	46	223-12477-2.....	44
222-12599-2.....	76	223-10889-2 .....	60	223-12364-4.....	47	223-12477-6.....	44
222-12599-3 .....	76	223-10986-1 .....	47	223-12365-2 .....	50	223-12477-6.....	128
222-12599-5.....	76	223-11089-3 .....	46	223-12366-2 .....	49	223-12477-8.....	44
222-12599-6.....	76	223-11185-1.....	54	223-12366-6 .....	49	223-12477-9.....	44
222-12599-9.....	76	223-11229-9.....	46	223-12367-2.....	49	223-12479-5.....	57
222-13618-1.....	76	223-12270-7.....	44	223-12367-4.....	49	223-12479-8.....	57
222-13618-2.....	76	223-12270-8 .....	44	223-12368-2 .....	56	223-12479-9.....	57
222-13618-3.....	76	223-12270-9.....	44	223-12368-4 .....	56	223-12480-2 .....	57
222-13618-5.....	76	223-12271-7.....	43	223-12368-6 .....	56	223-12480-7.....	57
222-13670-1.....	76	223-12271-8.....	43	223-12368-8 .....	56	223-12481-4.....	60
222-13678-1.....	76	223-12272-9.....	44	223-12369-7.....	57	223-12481-6.....	60
222-13678-2.....	76	223-12272-9.....	128	223-12369-9 .....	57	223-12481-8.....	60
222-13678-3.....	76	223-12273-2.....	53	223-12372-9.....	54	223-12482-9 .....	46
222-13678-4.....	76	223-12273-5.....	45	223-12373-2.....	42	223-12483-2 .....	50
222-13678-8.....	76	223-12284-7.....	57	223-12373-6.....	42	223-12483-5 .....	50
222-14180-3.....	76	223-12285-5 .....	57	223-12373-9.....	42	223-12483-8 .....	50
222-14180-5.....	76	223-12285-6 .....	57	223-12374-2.....	42	223-12484-2.....	49
222-14180-6.....	76	223-12285-7.....	57	223-12374-6.....	42	223-12484-6.....	49
222-14180-7.....	76	223-12285-8 .....	57	223-12374-7.....	42	223-12485-2 .....	50
222-14180-9.....	76	223-12285-9 .....	57	223-12374-8.....	42	223-12485-8 .....	50
223-10055-9 .....	46	223-12286-8 .....	60	223-12374-9.....	42	223-12531-2.....	46
223-10057-7.....	58	223-12287-8 .....	59	223-12377-7.....	45	223-12531-4.....	46
223-10057-8.....	58	223-12288-2 .....	59	223-12377-8.....	45	223-12531-6.....	46
223-10080-3 .....	44	223-12290-7.....	54	223-12380-6 .....	51	223-12531-8.....	46
223-10187-1.....	59	223-12291-2.....	54	223-12409-2 .....	56	223-12531-9.....	46
223-10263-8 .....	43	223-12291-4.....	54	223-12409-6 .....	56	223-12533-5.....	43
223-10297-5 .....	67	223-12291-6.....	54	223-12409-8 .....	56	223-12533-9 .....	43
223-10297-6 .....	67	223-12292-2.....	55	223-12409-9 .....	56	223-12535-9.....	54
223-10297-7.....	67	223-12292-5.....	55	223-12423-7.....	52	223-12539-6 .....	58
223-10307-2 .....	53	223-12292-9.....	55	223-12429-1.....	54	223-12541-5.....	49
223-10313-2.....	43	223-12295-2 .....	41	223-12432-2.....	52	223-12542-2.....	47
223-10313-7.....	44	223-12295-3 .....	41	223-12432-8.....	52	223-12542-7.....	47
223-10364-3 .....	56	223-12295-5.....	41	223-12452-5.....	45	223-12542-8 .....	47
223-10364-6 .....	56	223-12295-6 .....	41	223-12452-7.....	45	223-12562-2 .....	50
223-10374-3.....	63	223-12295-8 .....	41	223-12452-9.....	45	223-12562-7.....	50
223-10389-4 .....	57	223-12295-9 .....	41	223-12453-1.....	51	223-12562-8 .....	50
223-10530-4 .....	80	223-12296-1.....	41	223-12454-1.....	46	223-12563-2 .....	49
223-10540-1.....	153	223-12296-3 .....	41	223-12454-3.....	46	223-12563-5.....	49
223-10540-2 .....	153	223-12296-5 .....	41	223-12454-5.....	46	223-12563-9 .....	49
223-10550-1.....	48	223-12296-8 .....	41	223-12454-6.....	46	223-12564-2.....	56

# Index

223-12564-3.....	56	223-13052-8.....	54	223-13643-3.....	55	223-13702-6.....	80
223-12564-6.....	56	223-13054-4.....	59	223-13643-4.....	55	223-13702-7.....	80
223-12564-8.....	56	223-13057-2.....	49	223-13643-6.....	55	223-13702-9.....	80
223-12567-1.....	77	223-13057-4.....	49	223-13643-8.....	55	223-13705-5.....	47
223-12571-2.....	43	223-13057-5.....	49	223-13655-1.....	60	223-13706-3.....	55
223-12573-6.....	49	223-13069-1.....	43	223-13655-2.....	60	223-13715-1.....	43
223-12577-2.....	59	223-13079-1.....	54	223-13655-4.....	60	223-13715-6.....	45
223-12577-8.....	59	223-13096-2.....	45	223-13655-7.....	60	223-13715-9.....	45
223-12580-2.....	59	223-13610-8.....	46	223-13658-1.....	45	223-13732-4.....	46
223-12582-5.....	59	223-13610-9.....	44	223-13658-2.....	45	223-13732-8.....	46
223-12583-1.....	41	223-13614-6.....	45	223-13658-4.....	45	223-13749-3.....	44
223-13016-2.....	44	223-13614-7.....	45	223-13658-5.....	43	223-13749-5.....	44
223-13016-3.....	44	223-13614-9.....	45	223-13658-6.....	43	223-13759-7.....	59
223-13016-4.....	44	223-13615-3.....	46	223-13658-7.....	43	223-13761-5.....	61
223-13016-6.....	44	223-13615-5.....	46	223-13658-9.....	45	223-13761-7.....	61
223-13016-7.....	44	223-13615-6.....	46	223-13665-7.....	64	223-13766-1.....	44
223-13016-9.....	44	223-13616-3.....	49	223-13665-8.....	64	223-13766-6.....	44
223-13021-1.....	43	223-13619-2.....	47	223-13665-9.....	64	223-13766-9.....	46
223-13021-3.....	50	223-13619-9.....	47	223-13669-3.....	57	223-13770-5.....	55
223-13021-4.....	51	223-13620-8.....	51	223-13669-4.....	57	223-13770-6.....	55
223-13021-6.....	51	223-13621-1.....	44	223-13671-2.....	56	223-13785-8.....	63
223-13021-7.....	51	223-13621-6.....	44	223-13671-9.....	56	223-13791-5.....	47
223-13023-1.....	43	223-13621-8.....	44	223-13672-3.....	49	223-14082-3.....	42
223-13023-2.....	50	223-13622-1.....	47	223-13672-8.....	49	223-14082-5.....	42
223-13023-3.....	50	223-13622-3.....	47	223-13675-2.....	50	223-14082-6.....	42
223-13024-1.....	47	223-13622-7.....	47	223-13677-2.....	50	223-14083-3.....	41
223-13024-4.....	47	223-13629-1.....	57	223-13677-5.....	51	223-14089-9.....	57
223-13024-8.....	47	223-13638-1.....	42	223-13679-3.....	58	223-14092-5.....	41
223-13025-6.....	49	223-13638-2.....	42	223-13679-6.....	58	223-14102-3.....	63
223-13028-2.....	60	223-13638-3.....	42	223-13679-8.....	58	223-14116-9.....	53
223-13028-4.....	60	223-13638-6.....	42	223-13679-9.....	58	223-14129-1.....	46
223-13032-1.....	42	223-13638-7.....	42	223-13685-1.....	60	223-14129-2.....	46
223-13032-3.....	42	223-13638-9.....	42	223-13686-1.....	48	223-14129-3.....	44
223-13032-4.....	42	223-13639-1.....	41	223-13692-3.....	55	223-14129-4.....	43
223-13032-6.....	42	223-13639-2.....	41	223-13693-1.....	53	223-14130-2.....	48
223-13032-9.....	42	223-13639-3.....	41	223-13693-2.....	53	223-14130-7.....	48
223-13033-2.....	53	223-13639-4.....	41	223-13693-4.....	53	223-14130-9.....	48
223-13040-1.....	63	223-13639-5.....	41	223-13693-6.....	53	223-14152-2.....	59
223-13040-3.....	61	223-13639-7.....	41	223-13693-9.....	53	223-14171-1.....	63
223-13040-7.....	61	223-13639-8.....	41	223-13694-1.....	64	223-14171-4.....	63
223-13040-9.....	61	223-13639-9.....	41	223-13694-3.....	64	223-14171-5.....	63
223-13048-1.....	51	223-13640-1.....	65	223-13694-6.....	64	223-14171-8.....	63
223-13048-5.....	51	223-13640-2.....	65	223-13694-7.....	64	223-14184-2.....	45
223-13048-6.....	51	223-13640-3.....	65	223-13698-4.....	56	223-14184-5.....	43
223-13048-8.....	51	223-13640-4.....	65	223-13699-7.....	59	223-14187-4.....	48
223-13049-3.....	46	223-13640-5.....	65	223-13700-7.....	155	223-14187-7.....	48
223-13050-2.....	56	223-13640-8.....	65	223-13700-8.....	155	223-14189-1.....	63
223-13050-4.....	56	223-13640-9.....	65	223-13700-9.....	155	223-14189-2.....	63
223-13051-1.....	54	223-13643-1.....	55	223-13702-1.....	80	223-14189-3.....	63
223-13051-2.....	54	223-13643-2.....	55	223-13702-5.....	80	223-14189-5.....	63

# Index

223-14189-6.....	63	223-14497-4.....	48	226-13718-2.....	118	251-14040-3.....	143
223-14189-7.....	63	223-14497-8.....	48	226-13718-3.....	118	251-14040-4.....	143
223-14189-9.....	63	226-10159-1.....	89	226-13753-9.....	87	251-14040-5.....	143
223-14190-1.....	61	226-10159-9.....	89	226-13756-9.....	86	251-14044-8.....	143
223-14190-2.....	61	226-10205-5.....	85	226-13773-4.....	91	251-14045-1.....	143
223-14190-4.....	61	226-10214-4.....	90	226-14097-4.....	90	251-14045-8.....	143
223-14190-5.....	61	226-10214-7.....	90	226-14097-5.....	89	251-14063-1.....	143
223-14190-6.....	61	226-10223-2.....	88	226-14111-1.....	85	251-14063-4.....	143
223-14190-7.....	61	226-10223-4.....	88	226-14111-2.....	86	251-14063-9.....	143
223-14214-2.....	45	226-10223-6.....	88	226-14111-3.....	86	251-14073-9.....	143
223-14214-4.....	44	226-10622-8.....	86	226-14111-4.....	86	251-14109-2.....	143
223-14214-5.....	45	226-11313-8.....	87	226-14123-2.....	87	251-14109-3.....	143
223-14214-8.....	43	226-11313-9.....	87	226-14123-3.....	87	267-001.03.....	73
223-14214-9.....	44	226-11315-1.....	87	226-14123-4.....	87	267-001.13.....	18
223-14215-2.....	65	226-11315-2.....	87	226-14123-5.....	87	267-001.17.....	18
223-14215-3.....	65	226-12335-7.....	117	226-14139-1.....	85	267-001.19.....	18
223-14215-4.....	65	226-12337-1.....	117	226-14157-1.....	86	267-001.36.....	73
223-14215-5.....	65	226-12337-2.....	118	226-14157-2.....	86	267-001.47.....	73
223-14234-4.....	46	226-12337-3.....	118	226-14157-3.....	86	267-001.60.....	73
223-14234-7.....	46	226-12337-4.....	118	226-14157-4.....	88	301-001.....	18
223-14238-4.....	58	226-12337-5.....	118	226-14157-5.....	88	301-001DK.....	24
223-14240-5.....	51	226-12337-6.....	118	233-13651-1.....	151	301-005.....	18
223-14241-2.....	67	226-12338-1.....	117	233-13651-6.....	151	301-005-S3.....	18
223-14241-5.....	67	226-12338-2.....	118	233-13651-7.....	151	301-020.....	18
223-14241-9.....	67	226-12338-3.....	118	233-14419-1.....	151	301-020.....	127
223-14244-6.....	61	226-12338-4.....	118	234-10396-2.....	137	301-020.....	128
223-14244-8.....	61	226-12338-5.....	118	234-10396-9.....	137	301-020-S3.....	18
223-14253-1.....	48	226-12338-6.....	118	234-10898-4.....	137	301-034.....	74
223-14253-2.....	48	226-12343-1.....	120	234-13101-2.....	137	301-134.....	74
223-14253-3.....	48	226-12343-2.....	120	234-13101-4.....	137	303-17546-1.....	149
223-14253-4.....	48	226-12343-5.....	120	234-13132-7.....	137	304-16337-1.....	74
223-14253-5.....	48	226-12508-5.....	157	234-13132-8.....	137	304-19167-1.....	74
223-14256-3.....	58	226-13058-3.....	120	234-13156-6.....	137	304-19230-1.....	74
223-14256-4.....	58	226-13058-5.....	120	234-13182-7.....	137	304-19437-1.....	74
223-14268-4.....	60	226-13095-7.....	157	234-13182-8.....	137	304-19509-1.....	74
223-14268-7.....	60	226-13097-3.....	120	235-13108-4.....	132	304-19548-1.....	74
223-14293-1.....	59	226-13673-1.....	117	235-13114-1.....	132	304-19787-1.....	74
223-14293-2.....	59	226-13673-4.....	118	243-001.10.....	73	321-581.....	99
223-14293-4.....	59	226-13673-5.....	118	243-001.20.....	73	322-581.....	99
223-14293-8.....	59	226-13673-6.....	118	248-602.20.....	137	322-861.....	99
223-14304-2.....	46	226-13716-1.....	117	248-602.25.....	137	323-581.....	99
223-14304-5.....	46	226-13716-2.....	118	248-610.01.....	73	324-581.....	99
223-14304-7.....	46	226-13716-3.....	118	248-803.16.....	156	324-861.....	99
223-14418-7.....	46	226-13716-4.....	118	248-803.17.....	156	325-581.....	99
223-14420-7.....	45	226-13716-5.....	118	248-803.20.....	156	326-581.....	99
223-14420-8.....	45	226-13717-1.....	117	251-10309-1.....	143	326-663.....	99
223-14424-5.....	50	226-13717-2.....	118	251-10309-2.....	143	328-581.....	99
223-14464-8.....	55	226-13717-3.....	118	251-10780-2.....	143	328-861.....	99
223-14464-9.....	54	226-13717-4.....	118	251-14040-1.....	143	330-581.....	99
223-14497-1.....	48	226-13718-1.....	118	251-14040-2.....	143	330-861.....	99

# Index

332-861.....	99	404-006-VS .....	93	406-054.....	18	406-708-008 .....	113
334-861.....	99	404-008 .....	25	406-054.....	127	406-708-009 .....	113
336-861.....	99	404-009 .....	25	406-054K .....	17	406-710-002 .....	113
338-861.....	99	404-010.....	24	406-054-VS .....	93	406-804-001 .....	111
340-861.....	99	404-011.....	80	406-055.....	18	406-805 .....	24
401-004-512.....	17	404-040.....	18	406-089K .....	75	406-806-001 .....	111
401-004-903 .....	17	404-040K .....	17	406-090K .....	75	406-808-001 .....	111
401-004-904 .....	17	404-040K-US .....	17	406-091K.....	75	406-808-005 .....	113
401-011-132.....	73	404-040K-V1-VS .....	93	406-092K.....	75	406-808-005-S3.....	113
401-013-131.....	73	404-040-VS .....	93	406-093K .....	75	406-810-002 .....	113
401-013-161.....	73	404-045.....	17	406-094K .....	75	408-001.....	14
401-013-171 .....	73	404-047K.....	17	406-103.....	27	408-001-S3 .....	14
401-016-312.....	73	404-054K.....	17	406-145K.....	75	408-004 .....	18
401-016-371.....	73	404-061.....	18	406-155K.....	75	408-004-S8-VS.....	93
401-019-132.....	73	404-063.....	18	406-158.....	18	408-004-VS .....	93
401-019-352.....	73	404-063-VS .....	93	406-158-S3 .....	18	408-005 .....	18
401-504-192.....	35	404-072.....	17	406-158-VS .....	93	408-006 .....	18
401-504-292.....	35	404-073-VS .....	93	406-162.....	18	408-008 .....	25
401-506-313.....	35	404-162.....	18	406-162-S8-VS .....	93	408-010.....	24
402-001 <sup>1)</sup> .....	14	404-164.....	18	406-162-VS .....	93	408-011.....	80
402-002 .....	15	404-203.....	27	406-163.....	18	408-013.....	28
402-003 .....	18	404-405-S3 .....	50	406-165K.....	75	408-022 .....	18
402-003K .....	17	404-603.....	15	406-166.....	18	408-023 .....	27
402-004 .....	18	404-611.....	16	406-167.....	18	408-033-S3 .....	27
402-006 .....	18	404-612.....	16	406-203 .....	27	408-054-VS .....	93
402-006K .....	17	404-612-MS .....	16	406-233.....	27	408-103.....	27
402-008K .....	17	404-662K .....	17	406-243-B .....	27	408-120.....	35
402-011.....	80	404-663K .....	17	406-351.....	41	408-154.....	18
402-116-161.....	26	404-673K.....	17	406-352.....	42	408-160.....	18
402-116-165.....	26	404-673K-V1-VS .....	93	406-361.....	41	408-160.....	128
402-603 .....	15	405-549-049 .....	34	406-362.....	42	408-162.....	18
402-606-191.....	32	405-551-049 .....	34	406-423N-VS.....	93	408-162-S8-VS .....	93
402-611.....	16	405-619-061.....	32	406-423W-VS.....	93	408-162-VS .....	93
402-612.....	16	406-001.....	14	406-426-VS .....	94	408-202 .....	15
403-006-651 .....	29	406-001-S3 .....	14	406-603 .....	15	408-202-S3 .....	15
404-001.....	14	406-002 .....	15	406-611.....	16	408-211.....	80
404-001-S3 .....	14	406-002-S3 .....	15	406-612.....	16	408-243-B .....	27
404-002 .....	15	406-004 .....	18	406-612-MS.....	16	408-313.....	46
404-002-S3 .....	15	406-004DK .....	24	406-613.....	15	408-351.....	41
404-003 .....	18	406-004K .....	17	406-704-001 .....	111	408-352.....	42
404-003DK.....	24	406-004-S3 .....	18	406-704-001-VS .....	111	408-361.....	41
404-003K .....	17	406-004-S8-VS .....	93	406-706-001 .....	111	408-362.....	42
404-003-S8-VS.....	93	406-004-VS .....	93	406-706-001-VS.....	111	408-413.....	43
404-003-VS .....	93	406-005 .....	25	406-708-001 .....	111	408-425W.....	51
404-004.....	18	406-008 .....	25	406-708-001-VS.....	111	408-453W.....	44
404-005.....	18	406-010.....	24	406-708-005 .....	113	408-603 .....	15
404-006 .....	18	406-011.....	80	406-708-005-S3.....	113	408-611.....	16
404-006DK.....	24	406-024.....	73	406-708-005-VS.....	113	408-612.....	16
404-006K .....	17	406-044-S1 .....	72	406-708-006 .....	113	408-612-MS.....	16
404-006-S8-VS.....	93	406-045K .....	75	406-708-007 .....	113	410-001.....	14

# Index

410-002.....	15	412-453W.....	44	446-308-001.....	52	471-006-311.....	67
410-003.....	27	412-603.....	15	446-310-001.....	52	471-006-319.....	68
410-003-B.....	27	412-611.....	16	446-312-001.....	52	471-006-320.....	68
410-004.....	19	412-612.....	16	446-315-001.....	52	471-006-351.....	67
410-004DK.....	24	415-403.....	43	450-204-002.....	97	471-008-130.....	67
410-008.....	25	415-405.....	50	450-206-002.....	97	471-008-131.....	67
410-010.....	24	415-413.....	43	451-004-260-VS.....	93	471-008-132.....	68
410-011.....	80	415-443W.....	44	451-004-462-VS.....	93	471-008-161.....	67
410-013.....	28	418-403.....	43	451-004-471-VS.....	93	471-008-211.....	67
410-018.....	19	418-405W.....	51	451-004-498-VS.....	93	471-008-314.....	67
410-022.....	19	418-407.....	49	451-004-518-VS.....	93	471-008-318.....	68
410-160.....	19	418-409.....	56	451-006-468-VS.....	93	471-008-345.....	67
410-162.....	19	418-413W.....	44	451-006-498-VS.....	93	471-008-351.....	67
410-163.....	19	422-416.....	56	451-006-518-VS.....	93	471-008-391.....	67
410-163.....	127	428-21543-2.....	149	453-004-471-S8-VS.....	95	471-010-161.....	67
410-163.....	128	428-21544-1.....	148	453-004-471-VS.....	95	471-010-211.....	67
410-164.....	19	428-21544-1.....	149	453-006-468-S8-VS.....	95	471-010-312.....	67
410-169.....	19	428-21545-1.....	149	453-006-468-VS.....	95	471-010-312.....	68
410-171.....	19	428-21546-2.....	149	454-504-041-VS.....	94	471-010-318.....	68
410-313.....	46	432-23031-1.....	113	455-529-048-S8-VS.....	97	471-010-351.....	67
410-403-S3.....	43	432-23077-1.....	161	455-529-048-VS.....	97	471-010-391.....	67
410-405.....	50	432-23676-1.....	113	455-529-068-S8-VS.....	97	471-012-161.....	67
410-413.....	43	432-24043-1.....	75	455-529-068-VS.....	97	471-012-211.....	67
410-443.....	43	432-24050-1.....	75	455-531-048-S8-VS.....	97	471-012-312.....	68
410-443W.....	44	432-24051-1.....	75	455-531-048-VS.....	97	471-012-391.....	67
410-603.....	15	432-24052-1.....	75	455-531-068-S8-VS.....	97	473-808-371.....	59
410-611.....	16	432-24162-1.....	113	455-531-068-VS.....	97	473-808-392.....	59
410-612.....	16	432-70024-1.....	144	455-546-048-S8-VS.....	97	474-506-061.....	69
410-612-MS.....	16	432-70673-1.....	75	455-546-048-VS.....	97	474-508-081.....	69
412-001.....	14	432-70674-1.....	75	455-546-068-VS.....	97	474-510-101.....	69
412-002.....	15	432-71483-1.....	75	455-565-068-VS.....	95	474-512-121.....	69
412-004.....	19	441-108-132.....	60	455-565-068-VS.....	97	474-515-151.....	69
412-008.....	25	443-218-001.....	50	455-569-048-VS.....	97	474-518-181.....	69
412-010.....	24	443-290-001.....	50	456-004K.....	17	474-606-331.....	68
412-011.....	80	443-306-343.....	63	456-004-S8-VS.....	93	474-608-351.....	68
412-014.....	19	443-410-161.....	61	456-004-VS.....	93	474-610-351.....	68
412-162.....	19	443-410-211.....	61	458-012.....	27	474-612-391.....	68
412-163.....	19	443-418-181.....	61	458-012-B.....	27	474-615-431.....	68
412-163.....	128	445-513-181.....	58	460-708-001.....	67	474-618-441.....	68
412-164.....	19	445-516-061.....	58	466-419-001.....	80	476-006-001.....	69
412-169.....	19	445-517-222.....	58	466-429-001.....	80	476-008-001.....	69
412-403.....	43	445-519-041-VS.....	94	466-431-001.....	80	476-010-001.....	69
412-405.....	50	445-535-101.....	57	466-431-005.....	79	476-012-001.....	69
412-405W.....	51	445-713-152.....	62	466-431-006.....	79	476-015-001.....	69
412-407.....	49	445-717-221.....	62	466-431-009.....	79	502-051.....	31
412-409.....	56	445-721-121.....	62	466-439-001.....	80	502-051.....	31
412-423.....	43	445-735-101.....	62	471-004-191.....	67	502-052.....	31
412-423W.....	175	445-739-152.....	62	471-004-311.....	67	502-053.....	31
412-433.....	43	445-806-351.....	63	471-006-161.....	67	502-053.....	31
412-453.....	43	445-910-551.....	62	471-006-192.....	67	502-054.....	31

# Index

502-054.....	31	504-108-VS .....	96	506-025.....	33	508-005 .....	33
502-056.....	31	504-109.....	33	506-026 .....	33	508-005 .....	33
502-056.....	31	504-110.....	33	506-030 .....	31	508-005 .....	33
502-101 .....	31	504-111.....	33	506-030 .....	32	508-006 .....	31
502-102 .....	31	504-112.....	33	506-030 .....	32	508-006 .....	31
502-154.....	31	504-114.....	32	506-030 .....	32	508-006 .....	33
502-161 .....	31	504-115.....	32	506-032.....	33	508-006 .....	33
502-206K .....	29	504-161 .....	31	506-032.....	33	508-007.....	31
504-003 .....	28	504-161-VS.....	94	506-032.....	33	508-007.....	31
504-004.....	20	504-162 .....	31	506-033 .....	31	508-007.....	32
504-008 .....	22	504-200K .....	30	506-033 .....	31	508-007.....	32
504-019.....	81	504-200K-V1-VS .....	95	506-033 .....	32	508-007.....	32
504-019-AL .....	81	504-201K.....	30	506-034.....	31	508-008 .....	32
504-027.....	31	504-201-S8-VS .....	95	506-034.....	32	508-008 .....	32
504-027.....	31	504-201-VS .....	95	506-101.....	32	508-008 .....	33
504-045.....	23	504-202K .....	30	506-108.....	31	508-008 .....	33
504-051.....	33	504-202-S8-VS .....	95	506-108-S8-VS .....	96	508-012.....	32
504-051.....	33	504-202-VS .....	95	506-108-VS .....	96	508-013.....	33
504-051.....	33	504-203K .....	30	506-114.....	32	508-014.....	33
504-052.....	31	504-401 .....	31	506-139-S8-VS .....	96	508-023 .....	31
504-052.....	31	504-401-S1-VS .....	94	506-139-VS .....	96	508-023 .....	31
504-052.....	32	504-401-VS .....	94	506-140.....	31	508-023 .....	31
504-052.....	32	504-411 .....	31	506-140-S8-VS .....	96	508-023 .....	33
504-052.....	32	504-411-VS.....	94	506-140-VS .....	96	508-024 .....	31
504-054.....	31	504-412.....	47	506-142.....	31	508-025 .....	33
504-054.....	31	504-510K.....	29	506-142-S8-VS .....	96	508-030 .....	31
504-054.....	33	504-651.....	31	506-142-VS .....	96	508-030 .....	32
504-056.....	32	504-651.....	31	506-143-VS.....	96	508-030 .....	32
504-056.....	33	504-851.....	31	506-145.....	31	508-030 .....	32
504-056.....	33	504-851.....	31	506-202K .....	29	508-032.....	33
504-071.....	33	504-37184-2.....	144	506-214.....	31	508-032.....	33
504-071.....	33	504-37210-1.....	144	506-242.....	33	508-032.....	33
504-071.....	33	504-37211-1.....	144	506-342.....	32	508-033 .....	32
504-072.....	31	506-004 .....	28	506-345.....	32	508-034 .....	32
504-072.....	32	506-005 .....	31	506-346.....	32	508-054.....	31
504-073.....	31	506-005 .....	31	506-408 .....	22	508-054.....	32
504-073.....	33	506-005 .....	32	506-442.....	33	508-108.....	81
504-075.....	32	506-005 .....	32	506-508K .....	29	508-108.....	128
504-100-VS .....	96	506-006 .....	32	506-508-S8-VS.....	95	508-108.....	128
504-101.....	31	506-006 .....	32	506-508-VS .....	95	508-142.....	31
504-101-S8-VS .....	96	506-006 .....	33	506-510K.....	29	508-142-S8-VS .....	96
504-101-VS .....	96	506-007.....	33	506-510-S8-VS .....	95	508-142-VS .....	96
504-102.....	31	506-007.....	33	506-510-VS .....	95	508-144.....	31
504-102-S8-VS .....	96	506-007.....	33	506-511-K.....	29	508-145.....	31
504-102-VS .....	96	506-008 .....	22	506-511K-V1-VS .....	95	508-215-CU .....	81
504-103.....	28	506-010.....	20	506-511-S8-VS .....	95	508-242.....	33
504-103-VS .....	94	506-012.....	31	506-511-VS.....	95	508-303 .....	32
504-105.....	32	506-013.....	32	506-512K.....	29	508-303 .....	32
504-106.....	33	506-014.....	33	508-002-2 .....	22	508-303 .....	33
504-108.....	31	506-018.....	32	508-005 .....	33	508-303 .....	33
504-108-S8-VS .....	96						



# Index

508-304	32	525-32085-1	133	610-001	117	714-380	106
508-305	33	525-32086-1	133	610-004	119	714-380-K	107
508-320-CU	81	525-32087-1	133	612-001	117	714-380-VS	108
508-342	32	525-32098-1	133	624-25294-1	129	714-400-M	106
508-345	32	528-31341-3	148	624-25465-1	129	714-400-MK	107
508-346	32	528-36045-6	148	624-25478-1	129	714-400-M-VS	108
508-442	33	532-30739-1	113	624-25479-1	129	714-420	106
508-512K	29	532-32131-1	144	624-25480-1	129	714-420-K	107
508-602-2	22	532-32248-1	144	624-25481-1	129	714-420-VS	108
510-010	32	532-32454-1	144	624-25482-1	129	714-450	106
510-010	32	558-012	31	624-25483-1	129	714-450-K	107
510-010	32	558-012	31	624-27092-1	129	714-450-VS	108
510-017	31	558-012	31	626-25438-2	77	714-500	106
510-017	31	558-012	33	626-25540-2	77	714-500-K	107
510-017	31	558-012	33	626-25702-1	77	714-500-M	106
510-023	31	558-012	33	626-25716-2	77	714-500-MK	107
510-023	32	558-612	32	626-25717-2	77	714-500-M-VS	108
510-024	31	558-612	32	626-26246-1	123	714-500-VS	108
510-041	31	558-612	33	626-26696-2	77	714-580	106
510-041	32	558-612	33	626-26700-2	77	714-580-K	107
510-041	32	558-812	32	626-26701-2	77	714-580-M	106
510-042	33	558-812	32	628-25531-2	148	714-580-MK	107
510-042	33	558-812	32	628-26452-2	148	714-580-M-VS	108
510-044	31	558-812	33	628-36062-3	148	714-580-VS	108
510-044	32	558-812	33	638-37548-1	167	716-220	106
510-044	32	558-912	32	638-37549-2	167	716-220-K	107
510-102	22	558-912	32	651-28685-1	140	716-220-VS	108
510-142	31	558-912	32	651-28691-1	140	716-300	106
510-145	31	558-912	33	651-29124-1	140	716-300-K	107
510-242	33	558-913	32	714-180	106	716-300-M	106
510-341	32	568-342	32	714-180-K	107	716-300-MK	107
510-342	32	568-442	33	714-180-M	106	716-300-M-VS	108
510-343	32	586-342	32	714-180-MK	107	716-300-VS	108
510-344	32	586-442	33	714-180-M-VS	108	716-340	106
510-346	32	602-001	117	714-180-VS	108	716-340-K	107
510-410	47	602-002	117	714-220	106	716-380	106
510-413	47	604-001	117	714-220-K	107	716-380-K	107
510-442	33	604-002	117	714-220-VS	108	716-380-VS	108
512-412	47	604-003	117	714-260	106	716-400-M	106
514-018K	29	604-004	119	714-260-K	107	716-400-MK	107
514-018K-S1	30	604-014	118	714-260-M	106	716-400-M-VS	108
514-018K-V1-VS	95	604-015	118	714-260-MK	107	716-420	106
514-018-S8-VS	95	604-016	118	714-260-M-VS	108	716-420-K	107
514-018-VS	95	604-018	118	714-260-VS	108	716-420-VS	108
515-410	47	604-36879-1	158	714-300	106	716-450-MK	107
525-32080-1	133	606-010	117	714-300-K	107	716-450-M-VS	108
525-32081-1	133	606-014	119	714-300-M	106	716-500	106
525-32082-1	133	608-001	117	714-300-MK	107	716-500-K	107
525-32083-1	133	608-003	117	714-300-M-VS	108	716-500-M	106
525-32084-1	133	608-004	119	714-300-VS	108	716-500-MK	107

# Index

716-500-M-VS.....	108	833-330-016.....	79	908-411.....	14	995-001-526.....	123
716-500-VS.....	108	833-330-021.....	79	910-411.....	14	995-001-620.....	125
716-580.....	106	833-340-034.....	79	912-411.....	14	995-001-621.....	125
716-580-K.....	107	843-130-021.....	72	917-877.....	160	995-001-622.....	125
716-580-VS.....	108	843-130-022.....	72	941-206-104.....	119	995-001-623.....	125
718-340.....	106	843-130-023.....	72	941-206-108.....	119	995-001-950.....	124
718-340-VS.....	108	844-330-006.....	154	941-208-104.....	119	995-002-073.....	124
718-400-K.....	107	844-330-007.....	154	941-209-104.....	119	995-003-040.....	141
718-400-M.....	106	844-330-007.....	154	941-209-105.....	119	995-003-041.....	141
718-400-MK.....	107	853-370-002.....	113	941-210-104.....	119	995-003-042.....	141
718-400-M-VS.....	108	853-370-002-VS.....	113	941-212-104.....	119	995-003-043.....	141
718-450.....	106	853-380-002.....	113	941-213-104.....	119	995-003-044.....	141
718-450-K.....	107	853-380-002-VS.....	113	941-215-104.....	119	995-014-014.....	26
718-450-MK.....	107	853-380-003.....	113	941-217-104.....	119	995-340-000.....	26
718-450-M-VS.....	108	853-380-003-VS.....	113	941-217-105.....	119	995-340-000-S8.....	26
718-450-VS.....	108	853-380-004.....	113	941-218-101.....	119	995-340-350.....	26
718-500-K.....	107	853-380-004-VS.....	113	941-220-104.....	119	995-340-350-S8.....	26
718-500-M.....	106	853-380-005-VS.....	113	941-222-100.....	119	995-350-000.....	26
718-500-MK.....	107	853-380-006-VS.....	113	941-225-104.....	119	995-350-000-S8.....	26
718-500-M-VS.....	108	853-380-007-VS.....	113	941-606-000.....	120	996-001-890.....	143
718-580.....	106	853-390-002.....	113	941-608-000.....	120	001013.....	163
718-580-VS.....	108	853-390-002-VS.....	113	941-610-000.....	120	1110-00000001.....	112
734-180.....	109	853-390-003.....	113	982-120-040.....	104	1110-00000002.....	112
734-180-K.....	109	853-390-003-VS.....	113	982-120-041.....	104	001142.....	163
734-180-VS.....	110	853-390-004.....	113	982-120-061.....	104	2230-00000116.....	60
734-220.....	109	853-390-004-VS.....	113	982-120-100.....	104	005841.....	159
734-220-K.....	109	853-390-005.....	113	982-120-180.....	104	068874.....	151
734-220-VS.....	110	853-390-005-VS.....	113	982-750-111.....	112	091308.....	77
734-260.....	109	853-390-006-VS.....	113	982-760-102.....	103	AC-2879.....	151
734-260-K.....	109	853-540-010.....	113	982-760-120.....	103	AC-3398.....	151
734-260-VS.....	110	853-750-024.....	27	982-760-122.....	103	B3.U21.....	140
734-300.....	109	855-380-002.....	113	982-760-130.....	103	B7.....	141
734-300-K.....	109	855-380-002-VS.....	113	982-760-132.....	103	B7.U271.....	140
734-300-VS.....	110	855-380-003.....	113	982-760-142.....	103	BW3-2-S1.....	141
734-380.....	109	855-380-003-VS.....	113	982-760-160.....	103	BW7-S6.....	141
734-380-K.....	109	871-340-006.....	145	982-760-172.....	103	BW7-S7.....	141
734-380-VS.....	110	871-340-008.....	145	995-000-705.....	124	BW7-S8.....	141
734-420.....	109	871-360-006.....	145	995-000-705.....	175	BW7-S11.....	141
734-420-K.....	109	871-360-008.....	145	995-001-096.....	124	BW7-S14.....	141
734-420-VS.....	110	871-380-006.....	145	995-001-104.....	21	D301-001-MS.....	18
734-450.....	109	871-380-008.....	145	995-001-106.....	21	D301-005-MS.....	18
734-450-K.....	109	871-390-020.....	145	995-001-235.....	124	D301-020-MS.....	18
734-450-VS.....	110	871-390-023.....	145	995-001-500.....	124	D408-004-MS.....	18
734-500.....	109	898-510-000.....	120	995-001-500.....	124	D1127R02.5x0.5+A46.....	105
734-500-K.....	109	898-610-000.....	120	995-001-500.....	175	D72573-6x8ST+ZZ1.....	118
734-500-VS.....	110	898-710-000.....	120	995-001-501.....	124	DAK504-S1.....	36
734-580.....	109	898-710-001.....	120	995-001-502.....	124	DAK506.....	36
734-580-K.....	109	902-111.....	14	995-001-503.....	124	DAK508.....	36
734-580-VS.....	110	904-411.....	14	995-001-504.....	124	DAK510.....	36
833-020-022.....	79	906-411.....	14	995-001-525.....	123	DAK510-S1.....	37

# Index

DAK512 .....	36	DIN72573-3x10-ST.....	118	VL-05EAM3.....	99	WVN715-R02.5X0.5.....	102
DAR506 .....	20	DIN72573-4x6-ST.....	118	VL-06DAM3.....	99	WVN715-R04X0.85 .....	102
DAR508 .....	20	DIN72573-4x8-ST.....	118	VL-06EAM3.....	99	WVN715R04X0.85+A89 ..	102
DAR510 .....	20	DIN72573-4x10-ST.....	118	VL-08DAM3.....	99	WVN715-R06X1 .....	102
DAR510-S1 .....	20	DIN72573-5x6-ST.....	118	VL-08EAM3.....	99	WVN715-R06X1.25 .....	102
DAR524 .....	21	DIN72573-5x8-ST.....	118	VL-10DAM3.....	99	WVN715R06X1.25+A89 ..	102
DAR534 .....	21	DIN72573-5x10-ST.....	118	VL-10EAM3.....	99	WVN715-R08x1.25.....	102
DAT506 .....	23	DIN72573-6x6-ST.....	118	WVN200-4A0.4.....	130	WVN715-R010X1.5.....	102
DAT508 .....	23	DLY930-2.....	78	WVN200-4A0.4-S1 .....	130	WVN715R010X1.5+A89 ..	102
DAT510 .....	23	DLY931.....	78	WVN200-4A5 .....	130	WVN716-R04X0.85 .....	102
DAT510-S1 .....	23	DLY932.....	78	WVN200-4A8 .....	130	WVN716R04X0.85+A89 ..	102
DAT510-S5 .....	23	DY958 .....	30	WVN200-4A12 .....	130	WVN716-R06X1.25 .....	102
DAT512 .....	23	DY960 .....	30	WVN200-4A16 .....	130	WVN716R06X1.25+A89 ..	102
DIN908-G1-8A-5.8.....	80	DY961.....	30	WVN200-4A25 .....	130	WVN716-R08X1.25 .....	102
DIN908-G3-8A-5.8 .....	80	DY962 .....	30	WVN200-6B0.5 .....	130		
DIN908-M10x1-5.8 .....	80	DY964.....	23	WVN200-6B3 .....	130		
DIN908-M12x1.5-5.8 .....	80	DZ333 .....	73	WVN200-6B8 .....	130		
DIN908-M14x1.5-5.8 .....	80	DZ334.....	73	WVN200-6B12 .....	130		
DIN910-R1-2-5.8.....	80	K1 .....	139	WVN200-6B16 .....	130		
DIN910-R1-4x8-5.8.....	80	K3-S2.....	139	WVN200-6B20.....	130		
DIN910-R1-5.8.....	80	K6-S5.....	139	WVN200-6B40.....	130		
DIN910-R1-8-5.8.....	80	KW1 .....	139	WVN200-8B0 .....	130		
DIN910-R3-4-5.8.....	80	KW1-S2.....	139	WVN200-8B3 .....	130		
DIN910-R3-8-5.8.....	80	KW3-S1.....	139	WVN200-8B5 .....	130		
DIN912-M3x8-A4 .....	121	KW6-S1.....	139	WVN200-8B12 .....	130		
DIN931-M6x30-8.8 .....	121	KW6-S2.....	139	WVN200-8B16 .....	130		
DIN933-M4x10-8.8 .....	121	LAGN 120.....	145	WVN200-8B20 .....	130		
DIN2462-R04x1+A46 .....	105	P-78.01 .....	73	WVN200-8B32 .....	130		
DIN2462-R010x1+A46 .....	105	TK-350-V.....	139	WVN200-8D50.....	131		
DIN7513-BM4x20.....	121	TK-350-VM.....	139	WVN200-8D75 .....	131		
DIN7513-BM4x25 .....	121	TK-350-VMC.....	139	WVN200-8D120.....	131		
DIN7513-BM6x25 .....	121	UC.1010.100 .....	151	WVN200-8D220.....	131		
DIN7603-A6x10-CU .....	81	UC-1066-01 .....	151	WVN200-10B0 .....	130		
DIN7603-A8x11.5-CU .....	81	UC-1066-02 .....	151	WVN200-10B0.5 .....	130		
DIN7603-A12x18-CU .....	81	UC-1066-03 .....	151	WVN200-10B1 .....	130		
DIN7603-A14x18-CU .....	81	UC-1066-04 .....	151	WVN200-10B32.....	130		
DIN7603-A16x20-CU .....	81	UC-1066-05 .....	151	WVN200-10D120-S1....	131		
DIN7603-A17x21-CU .....	81	UC-1066-06 .....	151	WVN200-10D220-S1....	131		
DIN7603-A18x22-CU .....	81	UC-1066-10 .....	151	WVN200-10E6 .....	128		
DIN7603-A20x24-CU .....	81	UC-1066-14.....	151	WVN200-10E12 .....	128		
DIN7603-A21x26-CU .....	81	UFZ.0097.....	132	WVN200-10E12-S8 .....	128		
DIN7603-A22x27-CU .....	81	VL-01DAM3.....	99	WVN200-10E25 .....	128		
DIN7603-A27x32-CU .....	81	VL-01EAM3.....	99	WVN200-10E25-S8.....	128		
DIN7603-A30x36-CU .....	81	VL-02DAM3.....	99	WVN200-10E35 .....	128		
DIN7603-A33x39-CU .....	81	VL-02EAM3.....	99	WVN200-10E60.....	128		
DIN72573-2x6-ST.....	118	VL-03DAM3.....	99	WVN200-10E60-S8.....	128		
DIN72573-2x8-ST.....	118	VL-03EAM3.....	99	WVN701-4.....	111		
DIN72573-2x10-ST.....	118	VL-04DAM3.....	99	WVN701-6.....	111		
DIN72573-3x6-ST.....	118	VL-04EAM3.....	99	WVN701-8.....	111		
DIN72573-3x8-ST.....	118	VL-05DAM3.....	99	WVN711-10.....	112		



#### **Important information on product usage**

SKF and Lincoln lubrication systems or their components are not approved for use with gases, liquefied gases, pressurized gases in solution and fluids with a vapor pressure exceeding normal atmospheric pressure (1 013 mbar) by more than 0,5 bar at their maximum permissible temperature.



[skf.com](https://skf.com) | [skf.com/lubrication](https://skf.com/lubrication)

© SKF and LINCOLN are registered trademarks of the SKF Group.

© SKF Group 2023

The contents of this publication are the copyright of the publisher and may not be reproduced (even extracts) unless prior written permission is granted. Every care has been taken to ensure the accuracy of the information contained in this publication but no liability can be accepted for any loss or damage whether direct, indirect or consequential arising out of the use of the information contained herein.

**PUB LS/P1 15859 EN** · May 2023

Certain image(s) used under license from Shutterstock.com