

# Hydraulic Pumps T7 for variable speed drives

Denison Vane Technology



ENGINEERING YOUR SUCCESS.

**Content**

**T7, Denison Vane Pumps**

**General Information**

Introduction and product key features \_\_\_\_\_ 3

**Main Technical Data**

Main table for single pumps \_\_\_\_\_ 4

Main table for double pumps \_\_\_\_\_ 5

Inlet pressure range \_\_\_\_\_ 6

Outlet pressure range \_\_\_\_\_ 7

Pump operating range \_\_\_\_\_ 8 - 9

Control modes \_\_\_\_\_ 10

Hydraulic fluids and seals \_\_\_\_\_ 10

**Ordering Codes and Dimension Drawings**

**Pumps**

T7A \_\_\_\_\_ 11

T7AS \_\_\_\_\_ 12

T7ASW \_\_\_\_\_ 13

T7B \_\_\_\_\_ 14

T7BS \_\_\_\_\_ 15

T7D \_\_\_\_\_ 16

T7DS \_\_\_\_\_ 17

T7BB \_\_\_\_\_ 18

T7BBS \_\_\_\_\_ 19

T7DB \_\_\_\_\_ 20

T7DBS \_\_\_\_\_ 21

T7DD \_\_\_\_\_ 22

T7DDS \_\_\_\_\_ 23

Porting diagrams for double pumps \_\_\_\_\_ 24

**Technical Data**

Performance curves, maximum torque and loads on shaftS

T7A - T7AS \_\_\_\_\_ 25

T7ASW \_\_\_\_\_ 26

T7B - T7BS \_\_\_\_\_ 27

T7D - T7DS \_\_\_\_\_ 28

T7BB - T7BBS \_\_\_\_\_ 29

T7DB - T7DBS \_\_\_\_\_ 30

T7DD - T7DDS \_\_\_\_\_ 31

**Pump Selection**

Pump selection example \_\_\_\_\_ 32 - 33

Time restriction principle \_\_\_\_\_ 34

Time restriction tables \_\_\_\_\_ 35 - 38

**Circuit Design**

Pressure holding \_\_\_\_\_ 39

Decompression \_\_\_\_\_ 40

Dynamic characteristics \_\_\_\_\_ 40

Pump installation \_\_\_\_\_ 41

Start-up instructions \_\_\_\_\_ 42

Maintenance \_\_\_\_\_ 42

Warning \_\_\_\_\_ 43

## T7 pumps for variable speed drives

### Introduction

Parker Hannifin is proud to introduce in this catalogue its selection of hydraulic vane pumps especially dedicated to variable speed drive applications. The unique technology of these hydraulic pumps is allowing a wide range of operating speeds, to take the maximum benefits of modern power transmissions. When driven with asynchronous or synchronous electric motors and piloted by frequency controllers, they operate in the most efficient and reliable ways, allowing maximum energy savings.

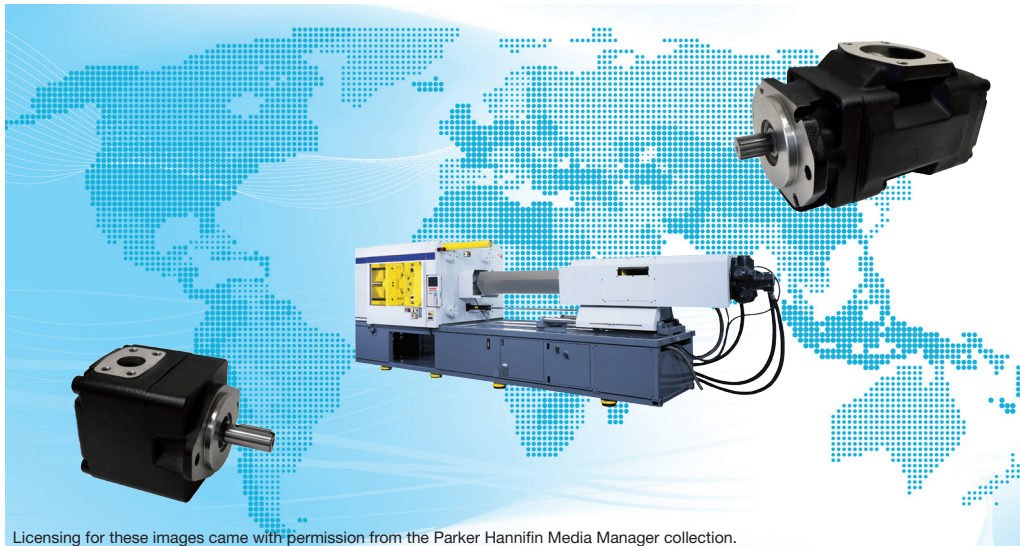

Licensing for these images came with permission from the Parker Hannifin Media Manager collection.

### Main benefits of variable speed drives

#### Energy savings

Up to 70% less electric Energy for the E Motor and less or no cooling for the hydraulic equipment.

#### Lower noise emissions.

#### Lower total cost of the hydraulic system

Smaller pump, less valves, less or no cooling, smaller fluid tank, increased lifetime for the components.

### Product key features

#### Reliable performance

These T7 hydraulic pumps have been designed especially for variable speed drives and are offering a wide speed range. Like all our T7 Series vane pumps, the performances do remain very stable over time, making these pumps an ideal solution for modern electro-hydraulically operated machines.

#### Long lifetime

The fully pressure balanced concept increases the pump lifetime over its full operating range while double lip vanes reduce the sensitivity to fluid pollution.

#### Low noise

The Denison Vane Technology allows very low noise levels over the entire operating range and during the whole life of the pump.

#### Versatility and compactness

With several displacements for the same installation size, the T7 are a very powerful and compact pumps. The various pumping units (cartridge kits) can also be combined with other pumping unit sizes in multiple pumps. This creates a wide range of multi flow pumps, very much adapted to the high power needs.

**Main Technical Data**

**T7, Denison Vane Pumps**

Single Pumps		Theoretical Displacement Vi cm <sup>3</sup> /rev.	Maximum Speed		Maximum Pressure				
Type	Ring size		HF-0, HF-1 HF-2	HF-4, HF-5 <sup>3)</sup>	HF-0, HF-2		HF-1, HF-4, HF-5		
			rpm	rpm	Int. bar	Cont. bar	Int. bar	Cont. bar	
T7A T7AS	E06	5,8	3600	1800	300	275	240	210	
	E10	9,8							
	E11	11,0							
	E13	12,8							
	E17	17,2							
	E20	19,8							
	E22	22,5	3000		275	240			
E25	24,9								
T7ASW	E22	22,0	3600	1800	300	275	240	210	
	E26	26,0							
	E28	28,0	3400						
	E30	30,0	3100						
	E32	31,8	3000		280	240			
	E34	34,0	2800						
	E36	36,0	2600						
	E40	40,0	2300						
T7B T7BS	E03	9,8	3600	1800	320 <sup>1)</sup>	290	240	210	
	E04	12,8							
	E05	15,9							
	E06	19,8							
	E07	22,5							
	E08	24,9							
	E09	28,0	3400			300	275		
	E10	31,8							
	E11	35,0	3000			280	240		
	E12	41,0							
	E14	45,0	3000 <sup>2)</sup>						
	E15	50,0							
T7D T7DS	E14	44,0	3000	1800	300	250	240	210	
	E17	55,0							
	E20	66,0							
	E22	70,3							
	E24	81,1							
	E28	90,0							
	E31	99,2	2800			280			
	E35	113,4							
	E38	120,6							
	E42	137,5							

<sup>1)</sup> Please consult Parker for application over 300 bar.

<sup>2)</sup> 2700 for pump with M0 ports.

<sup>3)</sup> with 1,2 m/s fluid velocity

HF-0, HF-2 = Antiwear Petroleum Base

HF-1 = Non Antiwear Petroleum Base

HF-4 = Water Glycols Solutions

HF-5 = Synthetic Fluids

Note : For further information or if the performance characteristics outlined in the table do not meet your particular requirements, please consult your local Parker office.



Double Pumps		Theoretical Displacement Vi cm <sup>3</sup> /rev.	Maximum Speed		Maximum Pressure			
Type	Ring size		HF-0, HF-1 HF-2	HF-4, HF-5 <sup>3)</sup>	HF-0, HF-2		HF-1, HF-4, HF-5	
			rpm	rpm	Int. bar	Cont. bar	Int. bar	Cont. bar
T7BB T7BBS T7DB T7DBS	E03	9,8	3000	1800	300	275	240	210
	E04	12,8						
	E05	15,9						
	E06	19,8						
	E07	22,5						
	E08	24,9						
	E09	28,0						
	E10	31,8						
	E11	35,0						
	E12	41,0						
	E14	45,0						
	E15	50,0	2700		280	240		
T7DB T7DBS	E14	44,0	3000	1800	300	250	240	210
	E17	55,0						
	E20	66,0						
	E22	70,3						
	E24	81,1						
	E28	90,0						
	E31	99,2						
	E35	113,4						
	E38	120,6						
	E42	137,5						
			2800		280			
			2500		260	230		
T7DD T7DDS	E14	44,0	3000	1800	300	250	240	210
	E17	55,0						
	E20	66,0						
	E22	70,3						
	E24	81,1						
	E28	90,0						
	E31	99,2						
	E35	113,4						
	E38	120,6						
	E42	137,5						
			2800		280			
			2500		260	230		

<sup>3)</sup> with 1,2 m/s fluid velocity

HF-0, HF-2 = Antiwear Petroleum Base

HF-1 = Non Antiwear Petroleum Base

HF-4 = Water Glycols Solutions

HF-5 = Synthetic Fluids

Note : For further information or if the performance characteristics outlined in the table do not meet your particular requirements, please consult your local Parker office.

**Inlet pressure range**

- **Minimum inlet pressure** : Read the minimum inlet pressure requirement in the below table, depending on the pump type, ring size and its maximum operating speed. Never go under 0,8 bar Absolute (11.6 psi Absolute).

Cartridge		Speed rpm													
Size	Ring	1200	1500	1800	2100	2200	2300	2500	2600	2700	2800	3000	3100	3400	3600
A AS	E06	0,80	0,80	0,80	0,80	0,80	0,80	0,80	0,80	0,80	0,80	0,80	0,80	0,80	0,80
	E10														
	E11														
	E13														
	E17														
	E20														
	E22														
E25															
ASW	E22	0,80	0,80	0,80	0,80	0,80	0,80	0,80	0,80	0,80	0,80	0,80	0,80	0,80	0,80
	E26														
	E28														
	E30														
	E32														
	E34														
	E36														
E40															
B BS	E03	0,80	0,80	0,80	0,80	0,80	0,80	0,80	0,80	0,80	0,80	0,80	0,80	0,80	0,80
	E04														
	E05														
	E06														
	E07														
	E08														
	E09														
	E10														
	E11														
	E12														
	E14														
E15															
D DS	E14	0,80	0,80	0,80	0,80	0,80	0,80	0,80	0,80	0,80	0,80	0,80	0,80	0,80	0,80
	E17														
	E20														
	E22														
	E24														
	E28														
	E31														
	E35														
	E38														
	E42														

Inlet pressure is measured at inlet flange with petroleum base fluids at viscosity between 10 and 65 cSt. The difference between inlet pressure at the pump flange and atmospheric pressure must not exceed 0,2 bar to prevent aeration.

Multiply absolute pressure by 1,25 for HF-4 fluid and by 1,35 for HF-5 fluid.

For double pumps, take the value of the cartridge requiring the highest absolute pressure.

- **Maximum inlet pressure** : Read the information on the product key sheet page. Standard shaft seals are limited to 0,7 bar (10 psig) but some allow 7 bar (100 psig).

### Outlet pressure range

- **Minimum outlet pressure** : It is recommended to always keep at least 1,5 bar (22 psi) differential between inlet and outlet.
- **Maximum outlet pressure** : Please read the charts in this catalogue for the Max continuous and the Max intermittent pressure ratings. Depending on the average pressure in cycle, either the continuous or the intermittent will be the limit.
- **Average pressure in cycle** : These Pumps may be operated intermittently at pressures higher than the recommended continuous rating when the time weighted average of pressure is less than or equal to the continuous duty pressure rating. This intermittent pressure rating calculation is only valid when the other parameters : speed, fluid, viscosity and contamination level are respected.

For total cycle time longer than 15 minutes, please consult your Parker representative.

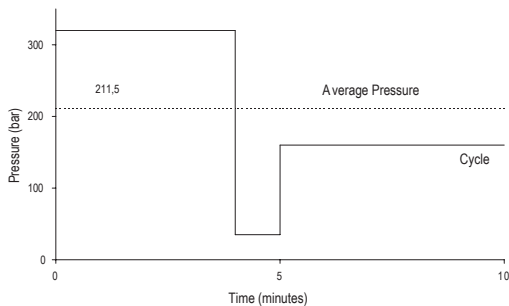

Example : T7B - E10  
 Duty cycle 4 min. at 320 bar  
               1 min. at 35 bar  
               5 min. at 160 bar

$$\frac{(4 \times 320) + (1 \times 35) + (5 \times 160)}{10} = 211,5 \text{ bar}$$

211,5 bar is lower than 290 bar allowed as continuous pressure for T7B - E10 with HF-0 fluid.

### How to read a pump operating range chart

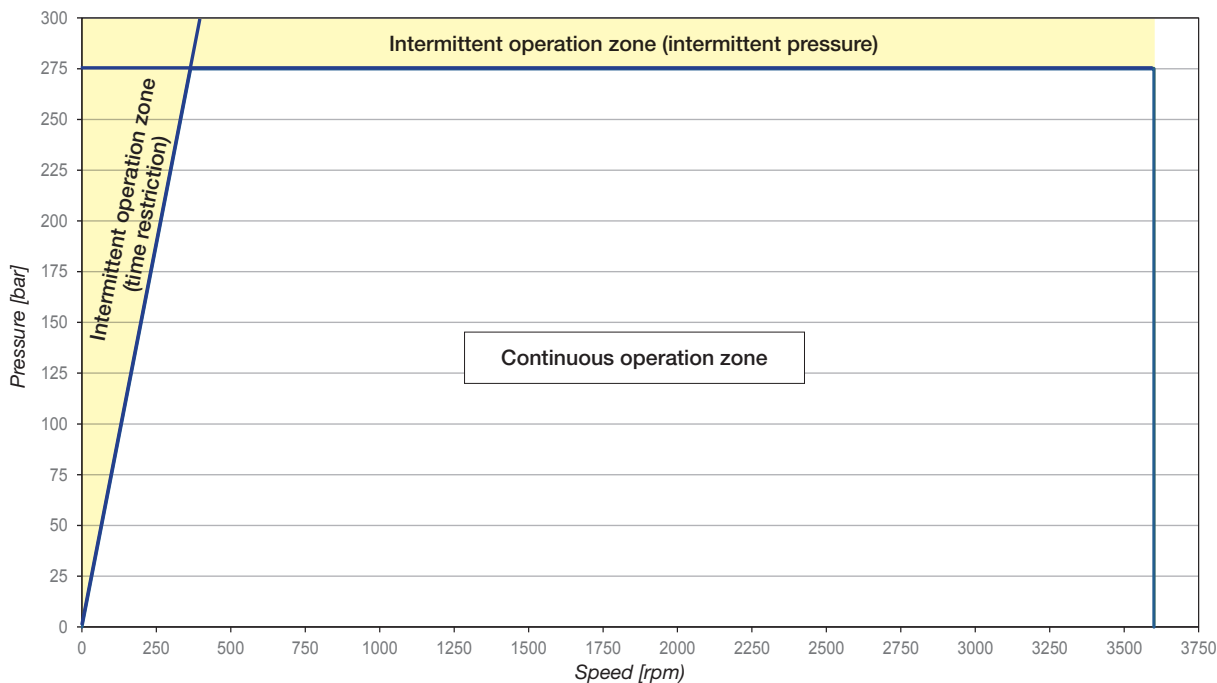

For double pumps, check the operating range of each pumping unit. Restrict the max. speed and max. pressure to the values indicated in the table page 5.

**T7A - T7AS Operating Range**

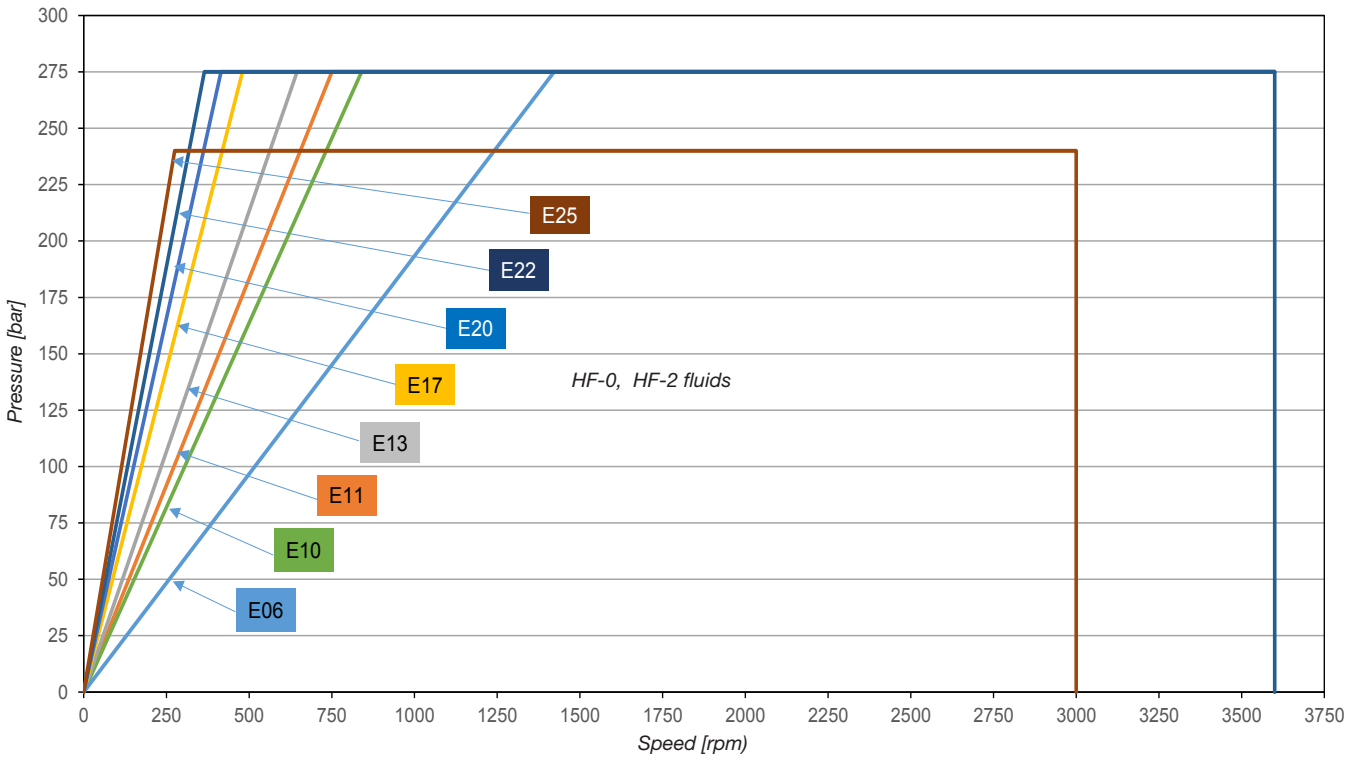

**T7ASW Operating Range**

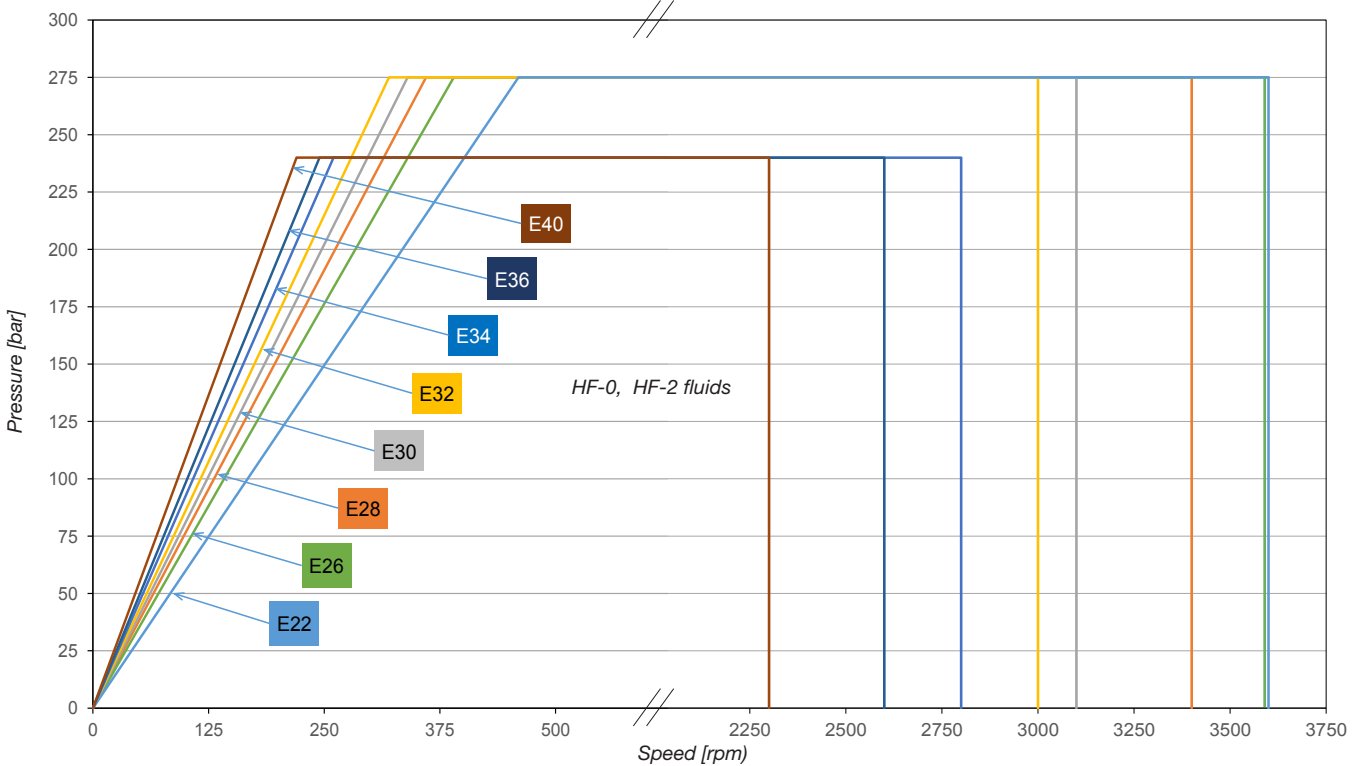



**T7B - T7BS Operating Range**

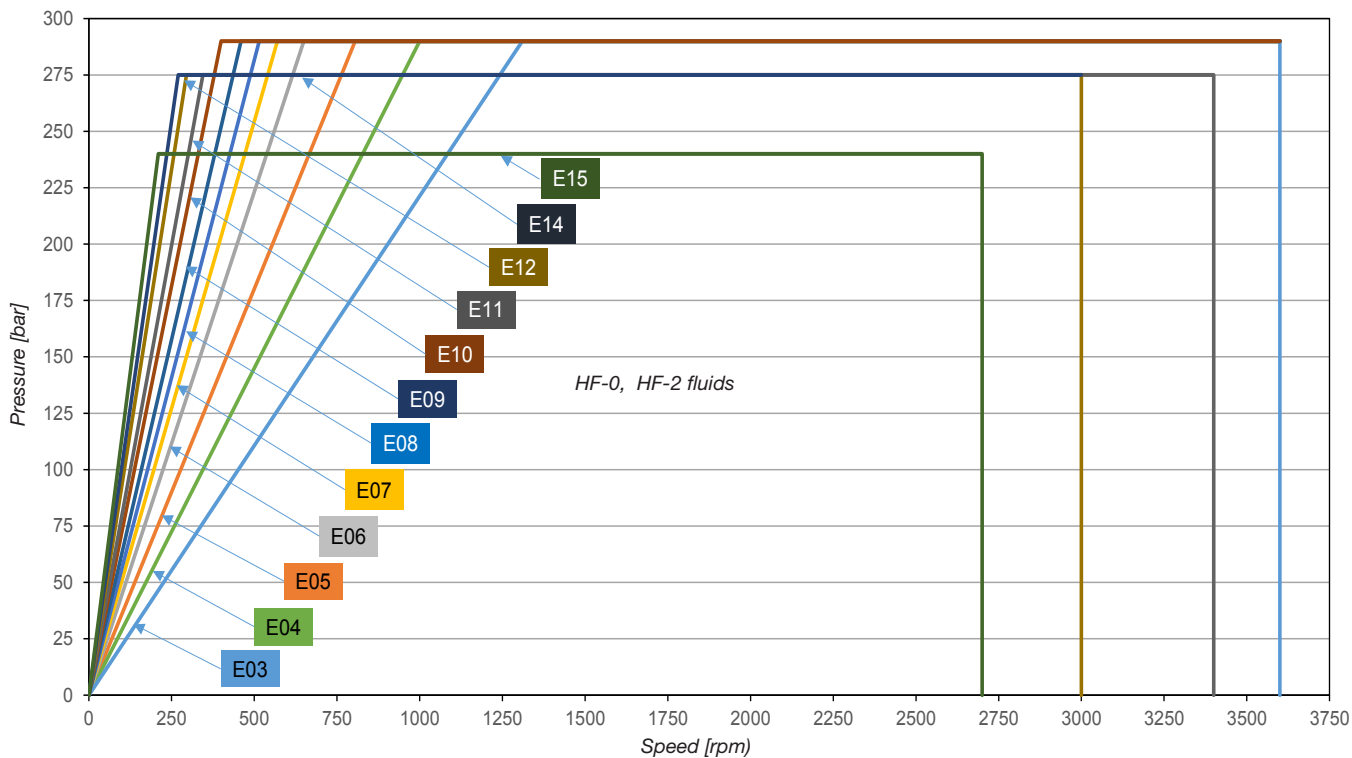

**T7D - T7DS Operating Range**

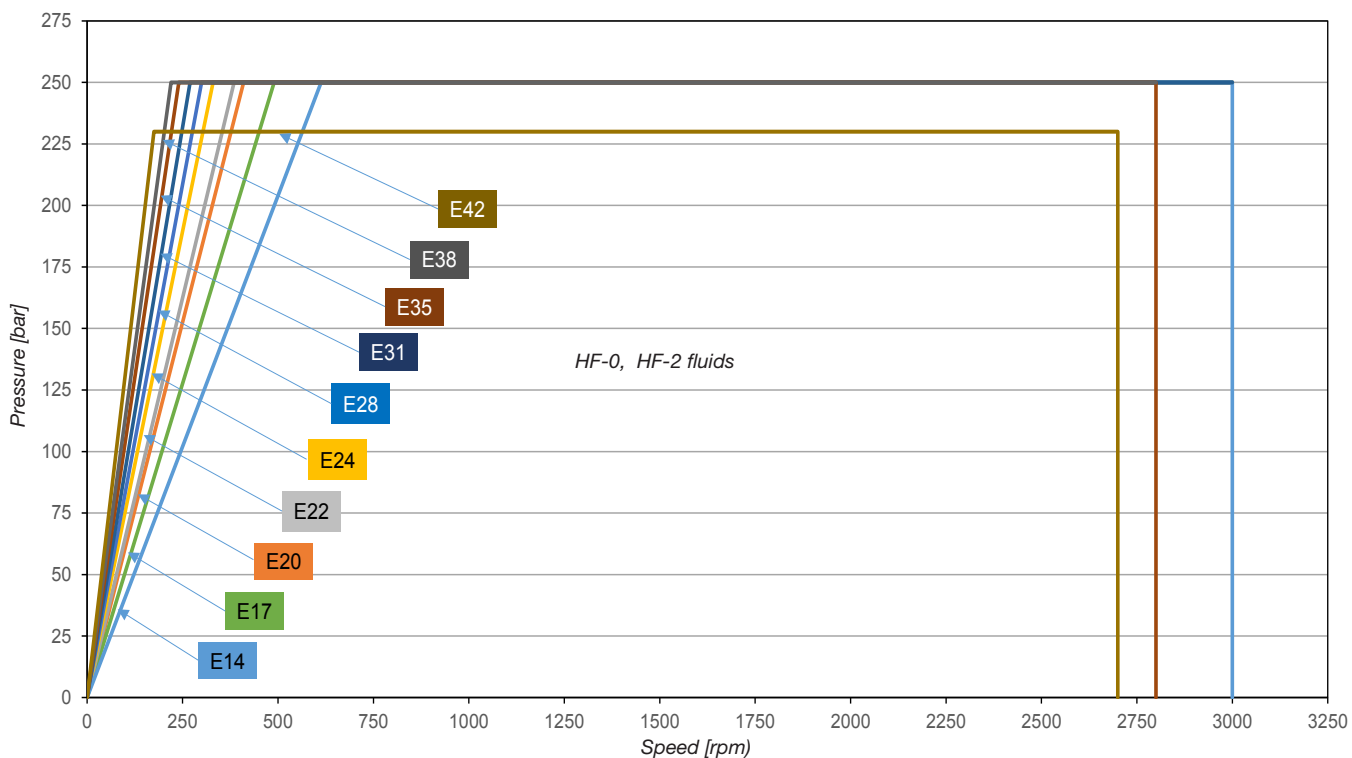

**Control modes**

Our fixed displacement pumps, when driven at variable speeds, may operate in hydraulic open loop circuits with various control modes.

**Flow control mode**

The pump flow is varied according to the speed command signal of the drive unit. The necessary pressure limitation is achieved by a pressure relief valve in a classic way.

**Pressure / Flow control mode**

The pump flow is varied according to the speed command signal of the drive unit which also offers the ability to switch in pressure control mode. This mode requires fast pressure sensors, a servomotor with high dynamics, as well as a fast drive unit. The necessary pressure limitation is achieved by the pump and motor unit that only deliver enough fluid to limit the pressure to the set value. A pressure relief valve remains necessary, but as a safety device only. This control mode may require a specific circuit design.

**Regenerative mode**

With a suitable hydraulic circuitry and when driven in its opposite rotation way, the pump may be used as a hydraulic motor, offering an energy recovery functionality. However, for this hydraulic motor function being limited, please consult your local Parker office.

**Hydraulic fluids**

**Recommended fluids**

Petroleum base anti-wear, anti-rust and anti-oxidation fluids (covered by Parker Denison HF-0 and HF-2 specifications). Maximum catalogue ratings and performance data are based on operation with these fluids.

**Acceptable alternate fluids**

The use of fluids other than petroleum based antiwear R & O fluids requires the maximum ratings of the pumps to be reduced, when the minimum inlet pressures must be increased.

**Fluids viscosity**

The minimum Viscosity Index is 90. The kinematic viscosity range is as below. Over or under these values, please contact Parker.

Max. (cold start, low speed & pressure) ___ 2000 cSt	Min. (full speed & pressure for HF-1, HF-4 & HF-5 fluids) _____ 18 cSt
Max. (full speed & pressure) _____ 108 cSt	Min. (full speed & pressure for HF-0 & HF-2 fluids) _____ 10 cSt
Optimum (max. lifetime) _____ 30 cSt	

**Fluids temperatures**

The usual limiting factor of temperature (low or high) comes from the obtained viscosity. The seals are sometimes the limit.

Maximum fluid temperature (also depends on min. viscosity)	Minimum fluid temperature (also depends on max. viscosity).
° C    ° F	° C    ° F
HF-0, HF-1, HF-2 _____ + 100 (+ 212)	HF-0, HF-1, HF-2, HF-5 _____ - 18 (- 0.4)
HF-4 _____ + 50 (+ 122)	HF-4 _____ + 10 (+ 50)
HF-5 _____ + 70 (+ 158)	

**Filtration requirement**

The fluid must be cleaned before and during operation to maintain a contamination level of ISO 19 / 17 / 14 or NAS 1638 class 8 or better. No inlet strainer or inlet filter is allowed on the fixed displacement pumps for variable speed drives.

**Water contamination in the fluid**

The maximum acceptable content of water shall be limited to 0,10 % for mineral base fluids, and 0,05 % for synthetic fluids, crankcase oils, and biodegradable fluids. The eventual excess of water must be drained off the circuit.

**Types of seals**

NBR seals S1 : Use this seal type for standard applications : with mineral oil and fluid temperature less than + 90° C (+ 194° F).

S1 seals temperature range : - 40°C to + 107° C (- 40° F to + 225° F).

EPDM seals S4 : Use this seal type when recommended by the fluid manufacturer.

S4 seals temperature range : - 54° C to + 121° C (- 65° F to + 250° F).

FPM seals S5 : Use this seal type with some fire resistant fluids and/or fluid temperature higher than + 90° C (+194° F).

S5 seal temperature range : - 29° C to + 204°C (- 20° F to + 400°F).

**Model No.** **T7A - E17 - 2 R 00 - A 1 - 05 - M**

**T7A series - 80-A2-HW**  
ISO 2 bolts 3019-2 mounting flange

**Displacement**  
Volumetric displacement (cm<sup>3</sup>/rev.)

- E06 = 5,8
- E10 = 9,8
- E11 = 11,0
- E13 = 12,8
- E17 = 17,2
- E20 = 19,8
- E22 = 22,5
- E25 = 24,9

**Type of shaft**  
2 = keyed ISO R775

**Direction of rotation (shaft end view)**  
R = Clockwise  
L = Counter-clockwise

**Modifications**

Ex : NOP = Not painted

**Ports**

- 05 = BSPP threads
- S = 1.1/4" BSPP
- P = 3/4" BSPP

**Seal class**

- 1 = S1 BUNA N - 0,7 bar max. (for mineral oil)
- 5 = S5 VITON® - 0,7 bar max. (for mineral oil and fire resistant fluids)

**Design letter**

**Porting combination**

00 = standard

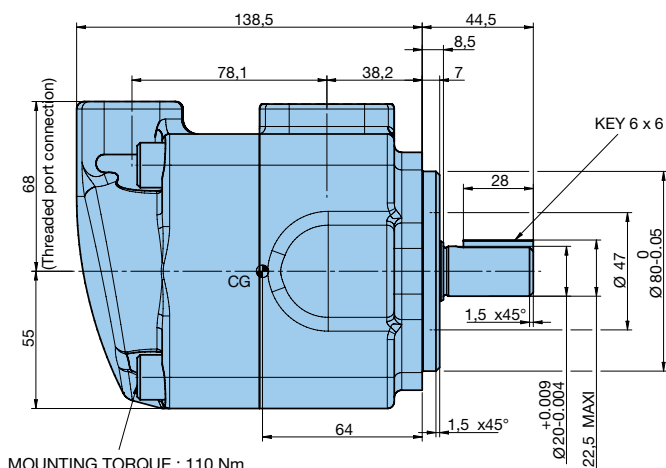
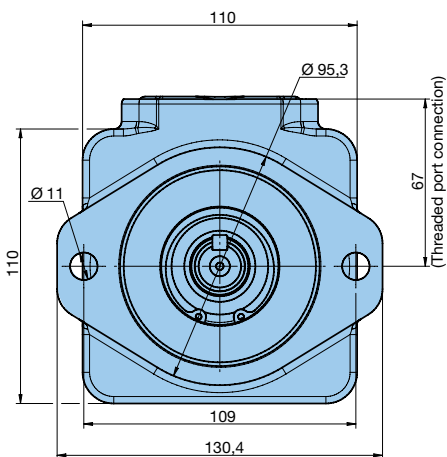
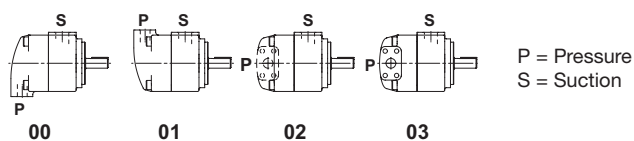

**Shaft Code 2**  
KEYED (ISO R775)

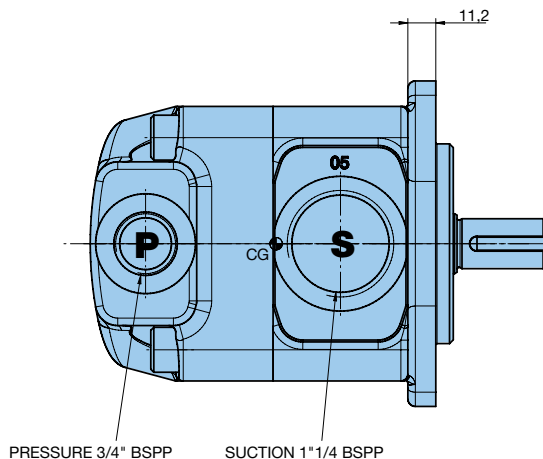

**T7AS - Ordering Code & Dimensions**

**T7, Denison Vane Pumps**

**Model No.** T7AS - E17 - 1 R 00 - A 1 - 06 - M

**T7AS series - SAE A 2 bolts**  
J744 mounting flange

**Displacement**  
Volumetric displacement (cm<sup>3</sup>/rev.)  
E06 = 5,8  
E10 = 9,8  
E11 = 11,0  
E13 = 12,8  
E17 = 17,2  
E20 = 19,8  
E22 = 22,5  
E25 = 24,9

**Type of shaft**  
1 = keyed (non SAE) Ø 19,05  
3 = splined 16/32 (SAE B) 13 teeth  
4 = splined 16/32 (SAE A) 9 teeth

**Modifications**  
Ex : NOP = Not painted

**Ports**  
M6 = 4 bolts SAE flanges J518 with Metric thread  
06 = 4 bolts SAE flanges J518 with UNC thread  
S = 1.1/4"  
P = 3/4"

**Seal class**  
1 = S1 BUNA N - 0,7 bar max. (for mineral oil)  
5 = S5 VITON® - 0,7 bar max. (for mineral oil and fire resistant fluids)

**Design letter**

**Porting combination**  
00 = standard

**Direction of rotation (shaft end view)**  
R = Clockwise  
L = Counter-clockwise

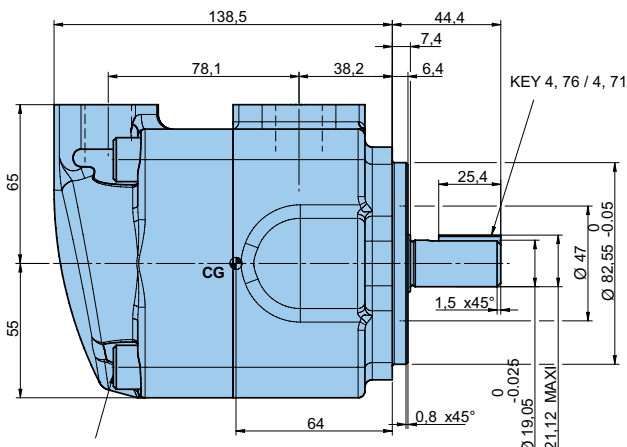
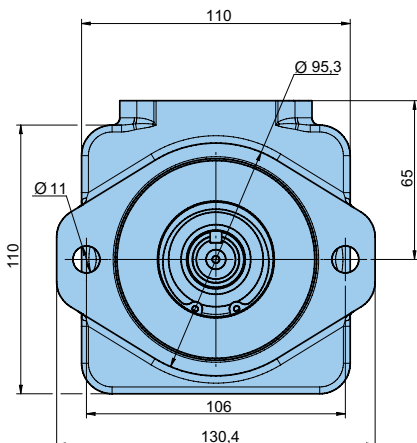
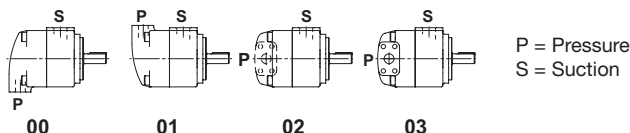

MOUNTING TORQUE : 110 Nm

**Shaft Code 1**  
KEYED (NON SAE)

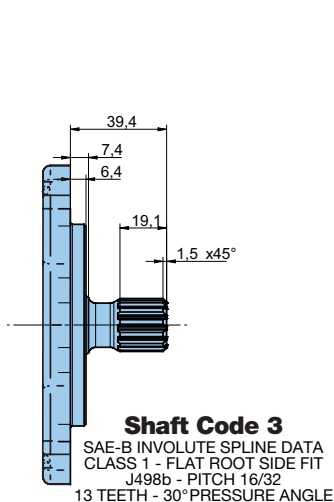

3/8"-16 UNC-2B x 19 DEEP - 4 HOLES - SAE VERSION  
M10 x 19 DEEP - 4 HOLES - METRIC VERSION

3/8"-16 UNC-2B x 17 DEEP - 4 HOLES - SAE VERSION  
M10 x 19 DEEP - 4 HOLES - METRIC VERSION

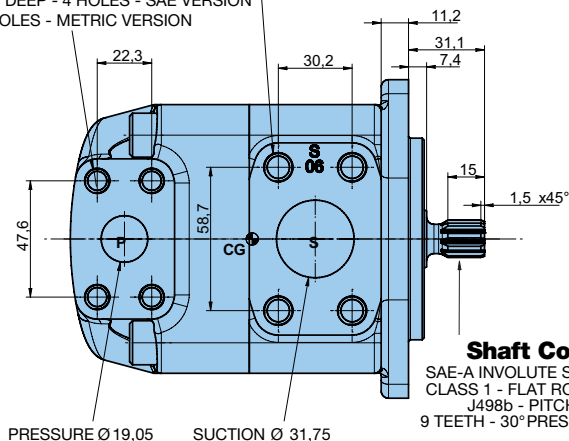

**Model No.** T7ASW - E32 - 1 R 00 - A 1 - 00 - M

**T7ASW series - SAE A 2 bolts**  
J744 mounting flange

**Displacement**  
Volumetric displacement (cm<sup>3</sup>/rev.)

- E22 = 22,0
- E26 = 26,0
- E28 = 28,0
- E30 = 30,0
- E32 = 31,8
- E34 = 34,0
- E36 = 36,0
- E40 = 40,0

**Type of shaft**

- 1 = keyed (non SAE) Ø 19,05
- 3 = splined 16/32 (SAE B) 13 teeth
- X = splined 16/32 (SAE A) 9 teeth

**Modifications**

Ex : NOP = Not painted

**Ports**

- M0 = 4 bolts SAE flanges J518 with Metric threads
- 00 = 4 bolts SAE flanges J518 with UNC threads
- S = 1.1/4"
- P = 3/4"

**Seal class**

- 1 = S1 BUNA N - 0,7 bar max. (for mineral oil)
- 5 = S5 VITON® - 0,7 bar max. (for mineral oil and fire resistant fluids)

**Design letter**

**Porting combination**

00 = standard

**Direction of rotation (shaft end view)**

- R = Clockwise
- L = Counter-clockwise

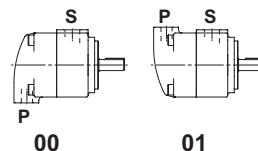

P = Pressure  
S = Suction

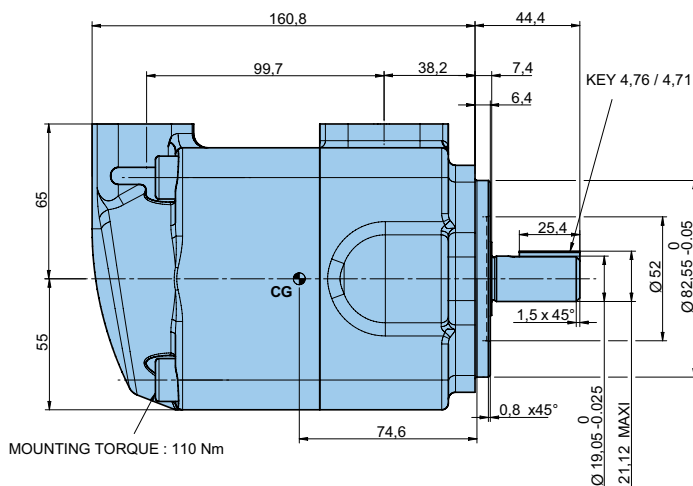
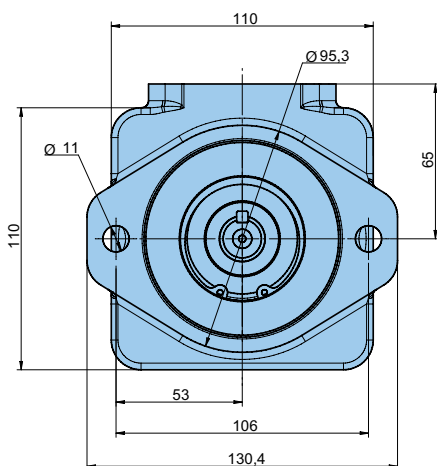

**Shaft code 1**  
(KEYED NO SAE)

7/16"-14 UNC-2B x 22 DEEP - 4 HOLES - SAE VERSION  
M10 x 19 DEEP - 4 HOLES - METRIC VERSION

3/8"-16 UNC-2B x 17 DEEP - 4 HOLES - SAE VERSION  
M10 x 19 DEEP - 4 HOLES - METRIC VERSION

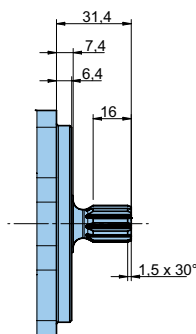

**Shaft Code X**

SAE-A INVOLUTE SPLINE DATA  
CLASS 1 - FLAT ROOT SIDE FIT  
J498b - PITCH 16/32  
9 TEETH - 30° PRESSURE ANGLE

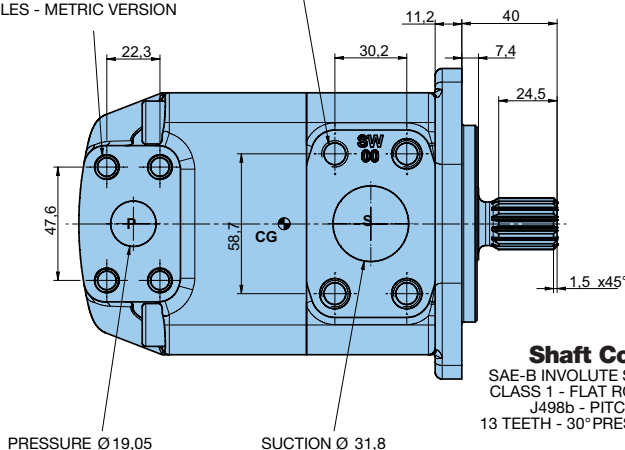

**Shaft Code 3**

SAE-B INVOLUTE SPLINE DATA  
CLASS 1 - FLAT ROOT SIDE FIT  
J498b - PITCH 16/32  
13 TEETH - 30° PRESSURE ANGLE

PRESSURE Ø 19,05

SUCTION Ø 31,8

**T7B - Ordering Code & Dimensions**

**T7, Denison Vane Pumps**

**Model No.**

**T7B - E10 - 2 R 00 - A 1 - M0 -  $\frac{M}{1}$**

**T7B series - 100 A2 HW**  
ISO 2 bolts 3019-2 mounting flange

**Displacement**  
Volumetric displacement (cm<sup>3</sup>rev.)

- E03 = 9,8    E09 = 28,0
- E04 = 12,8    E10 = 31,8
- E05 = 15,9    E11 = 35,0
- E06 = 19,8    E12 = 41,0
- E07 = 22,5    E14 = 45,0
- E08 = 24,9    E15 = 50,0

**Type of shaft**  
2 = keyed (ISO R775)

**Direction of rotation (shaft end view)**

- R = Clockwise
- L = Counter-clockwise

**Modifications**  
Ex : NOP = Not painted

**Ports**  
MW =  
S = Specific flange pattern  
P = 1" - SAE flange J518 with Metric threads  
M0 = 4 bolts SAE flanges J518 with Metric threads  
S = 1.1/2"  
P = 1"

**Seal class**  
1 = S1 BUNA N - 0,7 bar max. (for mineral oil)  
4 = S4 EPDM - 0,7 bar max. (for fire resistant fluids)  
5 = S5 VITON® - 0,7 bar max. (for mineral oil and fire resistant fluids)

**Design letter**

**Porting combination**  
00 = standard

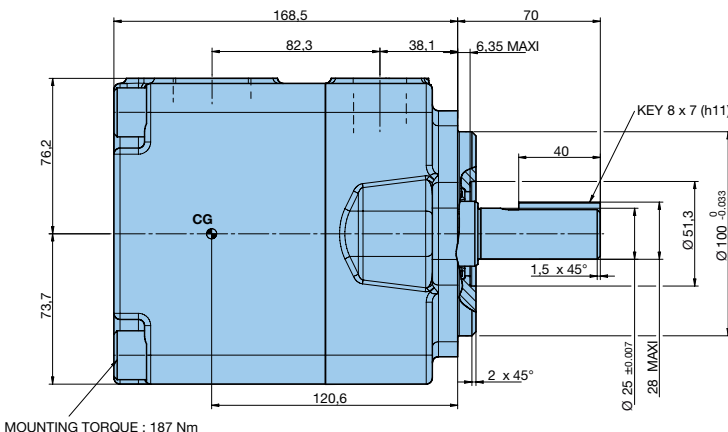
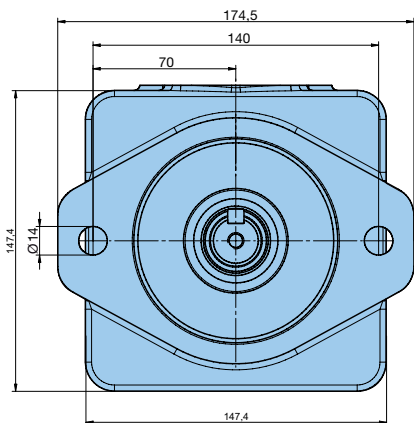
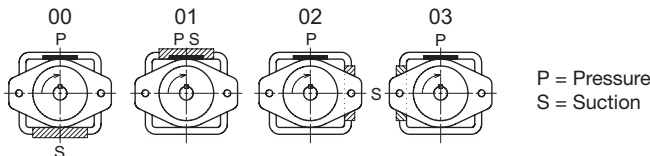

**2.1/2" inlet flange**  
034-68306-0  
+ O ring  
671-00137-0

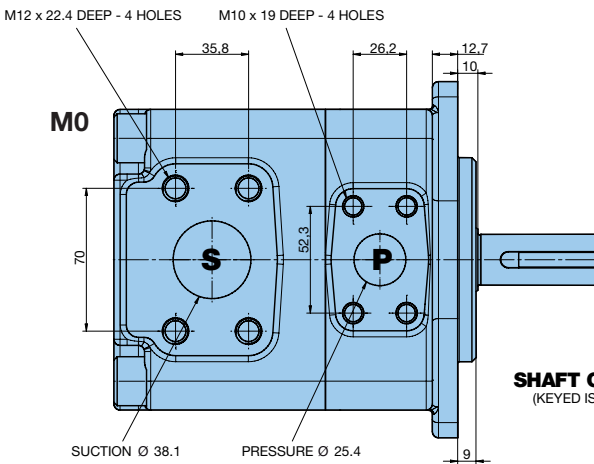
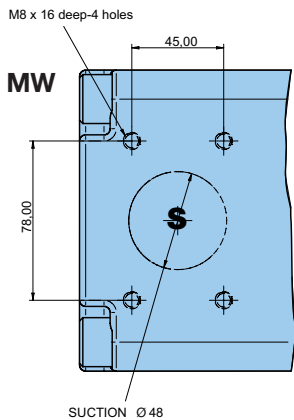
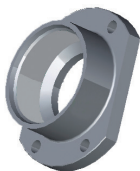

**SHAFT CODE 2**  
(KEYED ISO R775)



**T7D - Ordering Code & Dimensions**

**Model No**

**T7D - E42 - 5 R 00 - A 1 - MW -  $\frac{M}{M}$**

**T7D series - 125 A2 HW**  
 ISO 2 bolts 3019-2 mounting flange

**Displacement**  
 Volumetric displacement (cm<sup>3</sup>/rev.)  
 E14 = 44,0    E28 = 90,0  
 E17 = 55,0    E31 = 99,2  
 E20 = 66,0    E35 = 113,4  
 E22 = 70,3    E38 = 120,6  
 E24 = 81,1    E42 = 137,5

**Type of shaft**  
 5 = keyed (ISO 3019-2 - G32M)

**Direction of rotation (shaft end view)**  
 R = Clockwise  
 L = Counter-clockwise

**Modifications**  
 Ex : NOP = Not painted

**Ports**  
 MW = 4 bolts SAE flange J518 with Metric threads  
 S = 2.1/2"  
 P = 1.1/4"

**Seal class**  
 1 = S1 BUNA N - 0,7 bar max. (for mineral oil)  
 4 = S4 EPDM - 7 bar max. (for fire resistant fluids)  
 5 = S5 VITON® - 7 bar max. (for mineral oil and fire resistant fluids)

**Design letter**

**Porting combination**  
 00 = standard

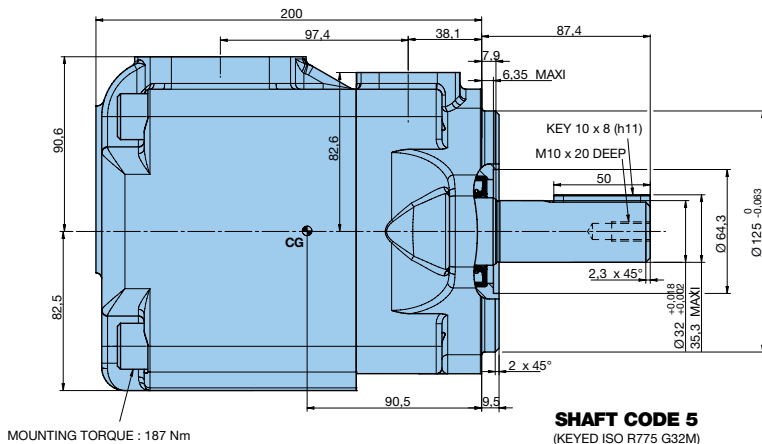
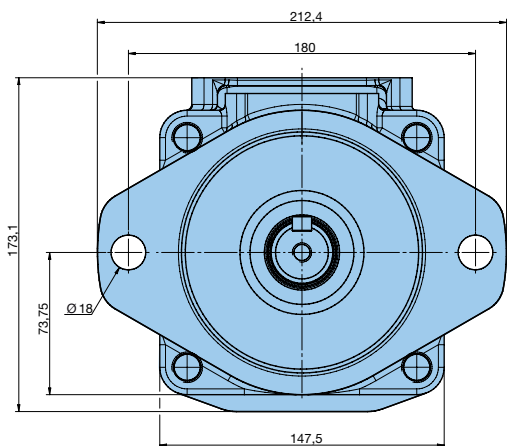
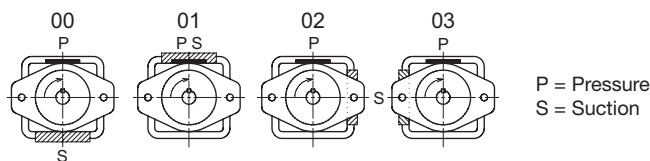

MOUNTING TORQUE : 187 Nm

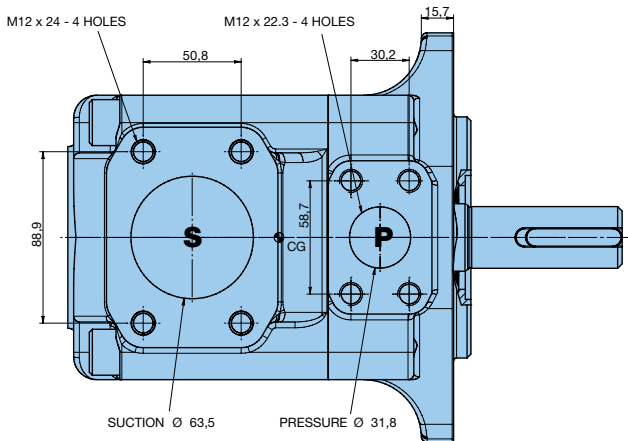





**T7BB - Ordering Code & Dimensions**

**T7, Denison Vane Pumps**

**Model No.** **T7BB - E10 - E10 - 5 R 00 - A 1 - MW - M**

**T7BB series - 100 A2 HW**  
ISO 2 bolts 3019-2 mounting flange

**Displacement P1 & P2**  
Volumetric displacement (cm<sup>3</sup>/rev.)

E03 = 9,8	E09 = 28,0
E04 = 12,8	E10 = 31,8
E05 = 15,9	E11 = 35,0
E06 = 19,8	E12 = 41,0
E07 = 22,5	E14 = 45,0
E08 = 24,9	E15 = 50,0

**Type of shaft**  
5 = keyed (ISO R775)

**Direction of rotation (shaft end view)**  
R = Clockwise  
L = Counter-clockwise

**Modifications**  
Ex : NOP = Not painted

**Ports**  
MW = 4 bolts SAE flange J518 with Metric threads  
S = 2.1/2"  
P1 = 1"  
P2 = 1"

**Seal class**  
1 = S1 BUNA N - 0,7 bar max. (for mineral oil)  
4 = S4 EPDM - 0,7 bar max. (for fire resistant fluids)  
5 = S5 VITON® - 0,7 bar max. (for mineral oil and fire resistant fluids)

**Design letter**

**Porting combination (see page 24)**  
00 = standard

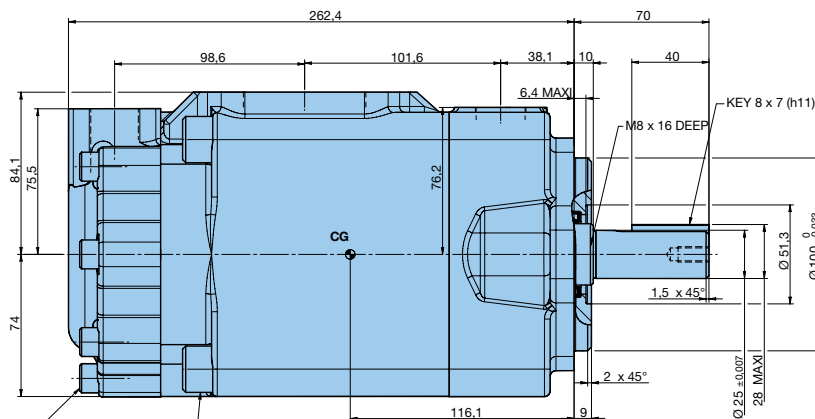
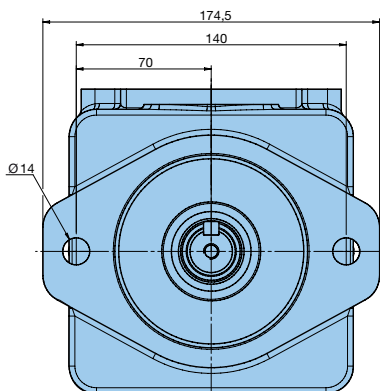

MOUNTING TORQUE : 61 Nm MOUNTING TORQUE : 187 Nm

**SHAFT CODE 5**  
(KEYED ISO R775)

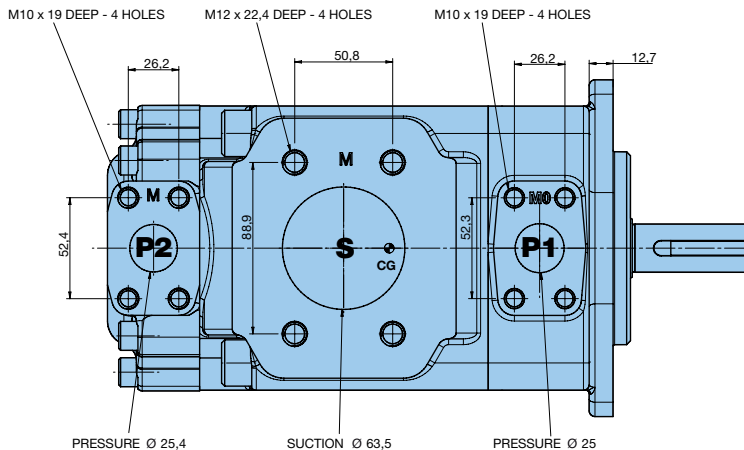

**Model No. T7BBS - E10 - E10 - 2 R 00 - A 1 - MW - M**

**T7BBS series - SAE B 2 bolts**  
J744 mounting flange

P1 P2

**Displacement P1 & P2**  
Volumetric displacement (cm<sup>3</sup>/rev.)

E03 = 9,8	E09 = 28,0
E04 = 12,8	E10 = 31,8
E05 = 15,9	E11 = 35,0
E06 = 19,8	E12 = 41,0
E07 = 22,5	E14 = 45,0
E08 = 24,9	E15 = 50,0

**Type of shaft**

- 2 = keyed (SAE BB)
- 3 = splined 12/24 (SAE B) 13 teeth

**Direction of rotation (shaft end view)**

- R = Clockwise
- L = Counter-clockwise

**Modifications**

Ex : NOP = Not painted

**Ports**

- MW = 4 bolts SAE flange J518 with Metric threads
- 0W = 4 bolts SAE flange J518 with UNC threads
- S = 2.1/2"
- P1 = 1"
- P2 = 1"

**Seal class**

- 1 = S1 BUNA N - 0,7 bar max. (for mineral oil)
- 4 = S4 EPDM - 0,7 bar max. (for fire resistant fluids)
- 5 = S5 VITON® - 0,7 bar max. (for mineral oil and fire resistant fluids)

**Design letter**

**Porting combination (see page 24)**

00 = standard

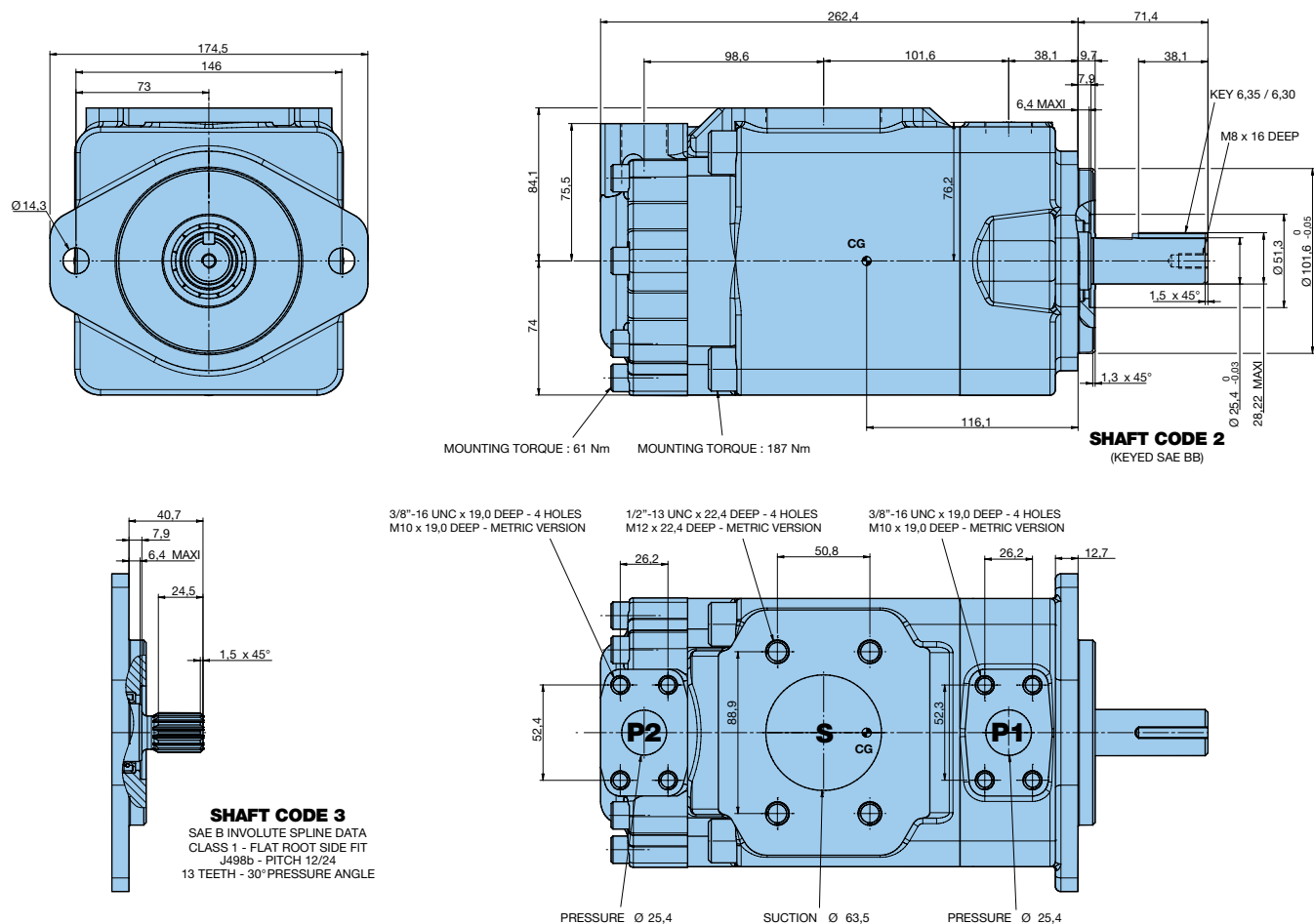

**Model No.**

**T7DB - E42 - E10 - 5 R 00 - A 1 M0 - M**

**T7DB series** - 125 A2 HW  
ISO 2 bolts 3019-2 mounting flange

**Displacement P1**

Volumetric displacement (cm<sup>3</sup>/rev.)  
E14 = 44,0 E28 = 90,0  
E17 = 55,0 E31 = 99,2  
E20 = 66,0 E35 = 113,4  
E22 = 70,3 E38 = 120,6  
E24 = 81,1 E42 = 137,5

**Displacement P2**

Volumetric displacement (cm<sup>3</sup>/rev.)  
E03 = 9,8 E09 = 28,0  
E04 = 12,8 E10 = 31,8  
E05 = 15,9 E11 = 35,0  
E06 = 19,8 E12 = 41,0  
E07 = 22,5 E14 = 45,0  
E08 = 24,9 E15 = 50,0

**Type of shaft**

5 = keyed (ISO 3019 -2 - G32 M)

**Modifications**

Ex : NOP = Not painted

**Ports**

M0 = 4 bolts SAE flanges J518 with Metric threads  
S = 3"  
P1 = 1.1/4"  
P2 = 1"

**Seal class**

1 = S1 BUNA N - 0,7 bar max. (for mineral oil)  
4 = S4 EPDM - 7 bar max. (for fire resistant fluids)  
5 = S5 VITON® - 7 bar max. (for mineral oil and fire resistant fluids)

**Design letter**

**Porting combination (see page 24)**

00 = standard

**Direction of rotation (shaft end view)**

R = Clockwise  
L = Counter-clockwise

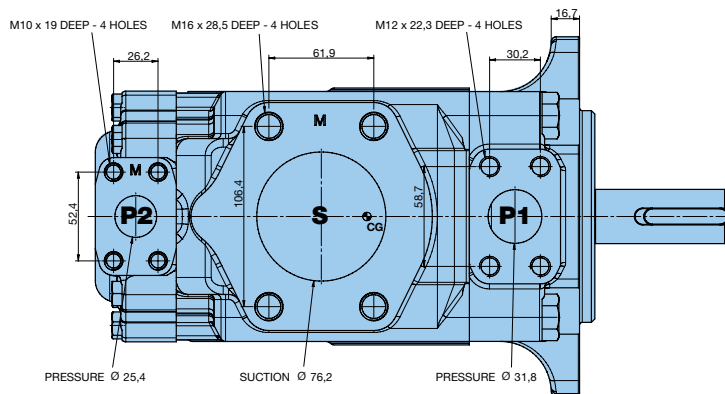
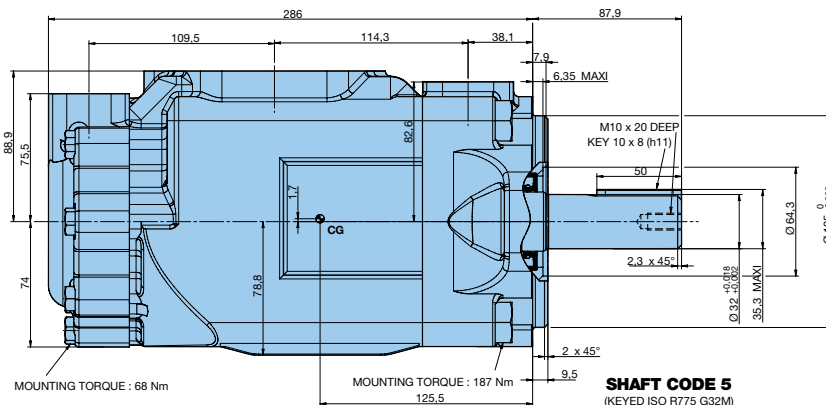
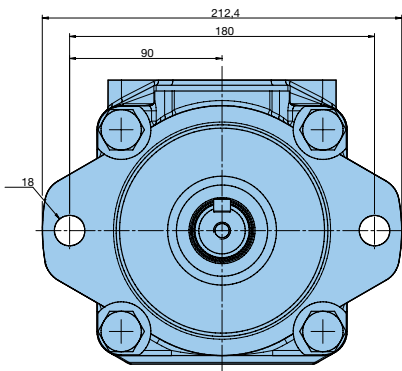

**Model No. T7DBS - E42 - E10 - 1 R 00 - A 1 M0 - M**

**T7DBS series** - SAE C 2 bolts  
J744 mounting flange

**Displacement P1**

Volumetric displacement (cm<sup>3</sup>/rev.)

E14 = 44,0 E28 = 90,0  
E17 = 55,0 E31 = 99,2  
E20 = 66,0 E35 = 113,4  
E22 = 70,3 E38 = 120,6  
E24 = 81,1 E42 = 137,5

**Displacement P2**

Volumetric displacement (cm<sup>3</sup>/rev.)

E03 = 9,8 E09 = 28,0  
E04 = 12,8 E10 = 31,8  
E05 = 15,9 E11 = 35,0  
E06 = 19,8 E12 = 41,0  
E07 = 22,5 E14 = 45,0  
E08 = 24,9 E15 = 50,0

**Type of shaft**

1 = keyed (SAE C)  
3 = splined 12/24 (SAE C) 14 teeth

**Modifications**

Ex : NOP = Not painted

**Ports**

M0 = 4 bolts SAE flange J518 with Metric threads  
00 = 4 bolts SAE flange J518 with UNC threads  
S = 3"  
P1 = 1.1/4"  
P2 = 1"

**Seal class**

1 = S1 BUNA N - 0,7 bar max. (for mineral oil)  
4 = S4 EPDM - 7 bar max. (for fire resistant fluids)  
5 = S5 VITON® - 7 bar max. (for mineral oil and fire resistant fluids)

**Design letter**

**Porting combination (see page 24)**

00 = standard

**Direction of rotation (shaft end view)**

R = Clockwise  
L = Counter-clockwise

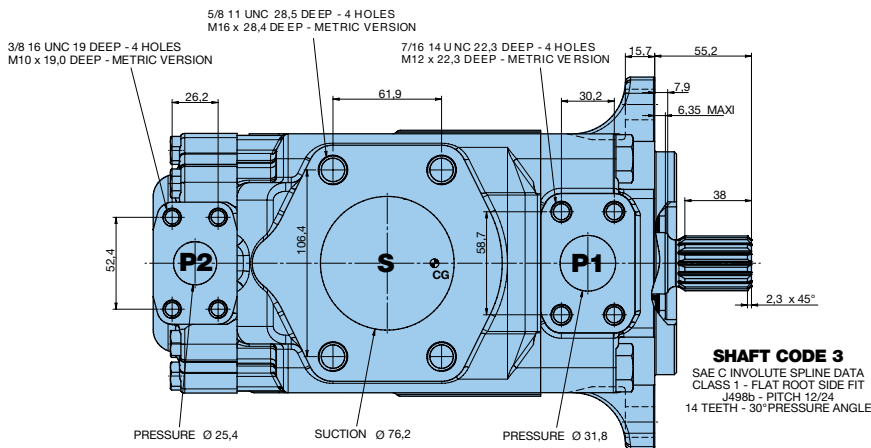
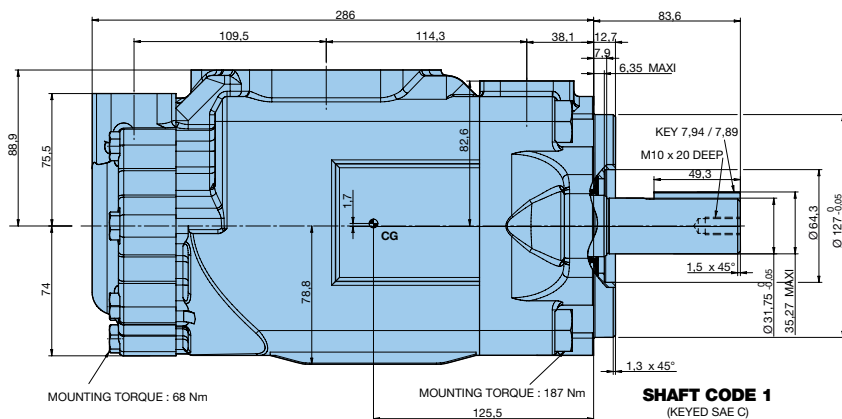
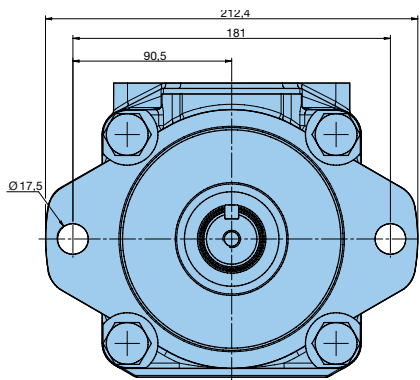

**Model No.**

**T7DD - E42 - E22 - 5 R 00 - A 1 M0 - M**

**T7DD series** - 125 B4 HW  
ISO 4 bolts 3019-2 mounting flange

P1 P2

**Modifications**  
Ex : NOP = Not painted

**Displacement P1 & P2**  
Volumetric displacement (cm<sup>3</sup>/rev.)

E14 = 44,0 E28 = 90,0  
E17 = 55,0 E31 = 99,2  
E20 = 66,0 E35 = 113,4  
E22 = 70,3 E38 = 120,6  
E24 = 81,1 E42 = 137,5

**Ports**  
M0 = 4 bolts SAE flanges J518 with Metric threads  
S = 4"  
P1 & P2 = 1.1/4"

**Seal class**  
1 = S1 BUNA N - 0,7 bar max. (for mineral oil)  
4 = S4 EPDM - 7 bar max. (for fire resistant fluids)  
5 = S5 VITON® - 7 bar max. (for mineral oil and fire resistant fluids)

**Type of shaft**  
5 = keyed (ISO 3019 -2 - G32 M)

**Design letter**

**Direction of rotation (shaft end view)**  
R = Clockwise  
L = Counter-clockwise

**Porting combination (see page 24)**  
00 = standard

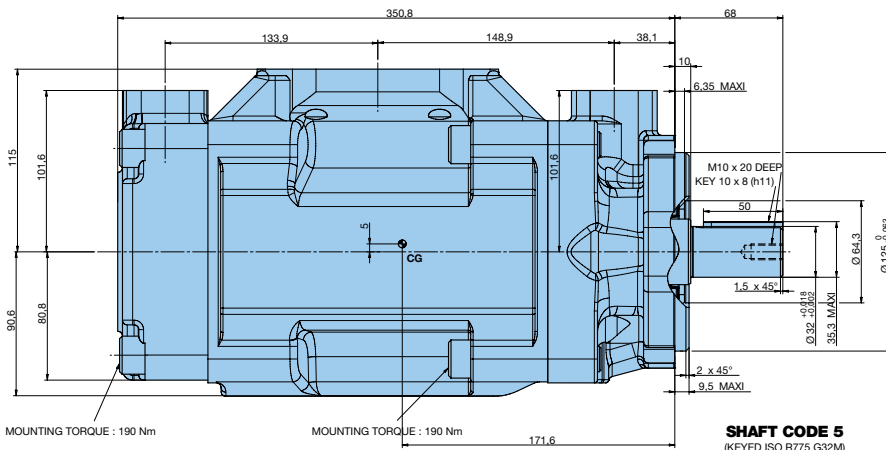
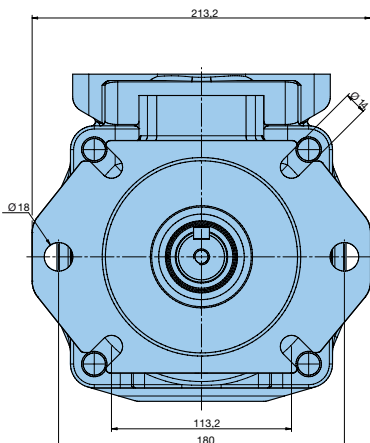

MOUNTING TORQUE : 190 Nm

MOUNTING TORQUE : 190 Nm

171.6

**SHAFT CODE 5**  
(KEYED ISO R775 G32M)

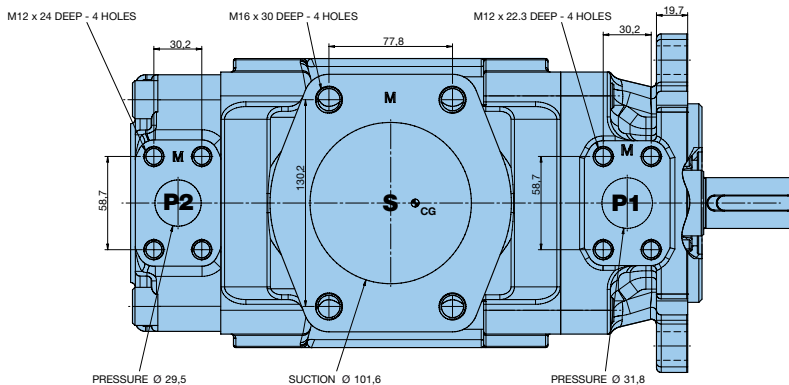

PRESSURE Ø 29,5

SUCTION Ø 101,6

PRESSURE Ø 31,8

**Model No. T7DDS - E42 - E22 - 1 R 00 - A 1 M0 - M**

**T7DDS series** - SAE C 6 bolts  
J744 mounting flange

**Displacement P1 & P2**

Volumetric displacement (cm<sup>3</sup>/rev.)

- E14 = 44,0    E28 = 90,0
- E17 = 55,0    E31 = 99,2
- E20 = 66,0    E35 = 113,4
- E22 = 70,3    E38 = 120,6
- E24 = 81,1    E42 = 137,5

**Type of shaft**

- 1 = keyed (SAE C)
- 2 = keyed (SAE CC)
- 3 = splined 12/24 (SAE C) 14 teeth
- 4 = splined 16/32 (SAE BB) 15 teeth

**Direction of rotation (shaft end view)**

- R = Clockwise
- L = Counter-clockwise

**Modifications**

Ex : NOP = Not painted

**Ports**

- M0 = 4 bolts SAE flanges J518 with Metric threads
- 00 = 4 bolts SAE flange J518 with UNC threads
- S = 4"
- P1 & P2 = 1.1/4"

**Seal class**

- 1 = S1 BUNA N - 0,7 bar max. (for mineral oil)
- 4 = S4 EPDM - 7 bar max. (for fire resistant fluids)
- 5 = S5 VITON® - 7 bar max. (for mineral oil and fire resistant fluids)

**Design letter**

**Porting combination (see page 24)**

00 = standard

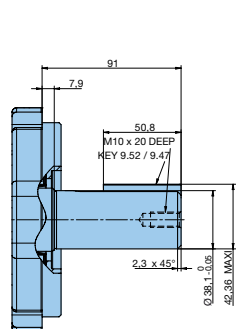
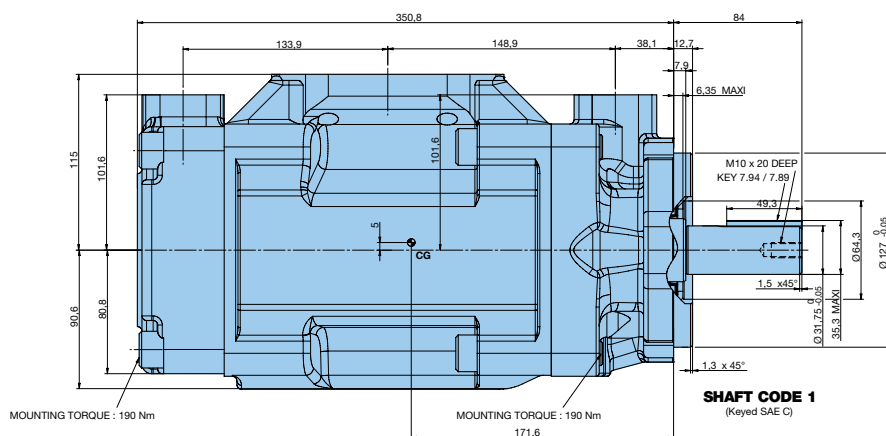
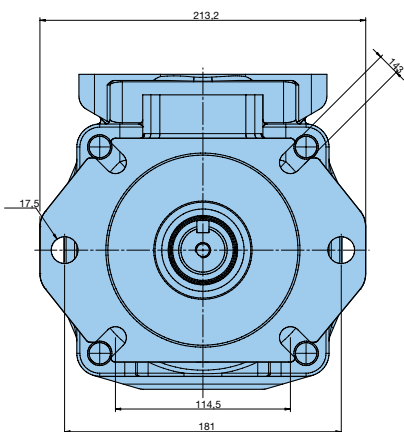

**SHAFT CODE 2**  
(KEYED SAE CC)

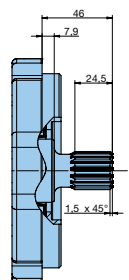

**SHAFT CODE 4**  
SAE BB INVOLUTE SPLINE DATA  
CLASS 1 - FLAT ROOT SIDE FIT  
J4989 - PITCH 16/32  
15 TEETH - 30° PRESSURE ANGLE

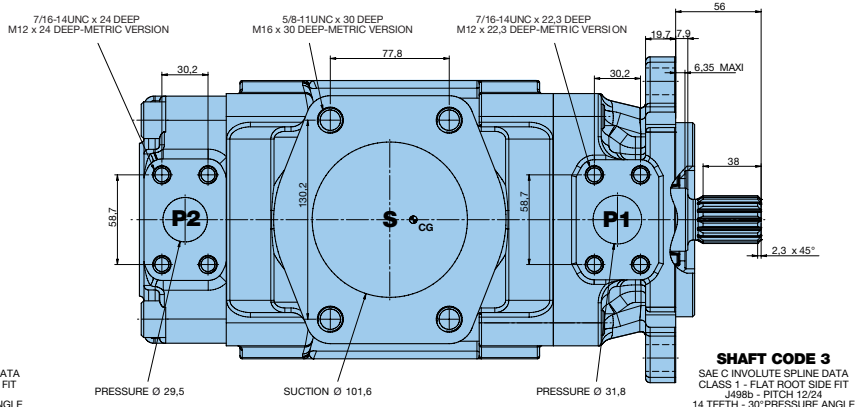

**SHAFT CODE 3**  
SAE C INVOLUTE SPLINE DATA  
CLASS 1 - FLAT ROOT SIDE FIT  
J4989 - PITCH 12/24  
14 TEETH - 30° PRESSURE ANGLE

**Ordering Code**

**T7, Denison Vane Pumps**

**Porting diagrams for double pumps**

<b>Pump type</b>	<b>00</b> P1-P2	<b>01</b> P1-P2	<b>02</b> S-P1-P2	<b>03</b> P1-P2	<b>04</b> P1	<b>05</b> P1	<b>06</b> P1	<b>07</b> P1-S
	<b>T7BB</b>							
	<b>T7BBS</b>							
<b>Pump type</b>	<b>08</b> P1-S	<b>09</b> P1-S	<b>10</b> P1	<b>11</b> P1	<b>12</b> P1	<b>13</b> P1	<b>14</b> P1	<b>15</b> P1
	<b>T7DB</b>							
	<b>T7DBS</b>							
<b>Pump type</b>	<b>16</b> P1	<b>17</b> P1	<b>18</b> P1	<b>19</b> P1	<b>20</b> P1	<b>21</b> P1	<b>22</b> P1	<b>23</b> P1
<b>Pump type</b>	<b>24</b> P1-S	<b>25</b> P1-S	<b>26</b> P1-S	<b>27</b> P1-S	<b>28</b> P1	<b>29</b> P1	<b>30</b> P1	<b>31</b> P1
<b>Pump type</b>	<b>00</b> P1-P2	<b>01</b> P1-P2	<b>02</b> S-P1-P2	<b>03</b> P1-P2	<b>04</b> P1	<b>05</b> P1	<b>06</b> P1	<b>07</b> P1-S
<b>T7DD</b>								
<b>T7DDS</b>	<b>08</b> P1-S	<b>09</b> P1-S	<b>10</b> P1	<b>11</b> P1	<b>12</b> P1	<b>13</b> P1	<b>14</b> P1	<b>15</b> P1



T7A - T7AS

Internal leakage (Typical)

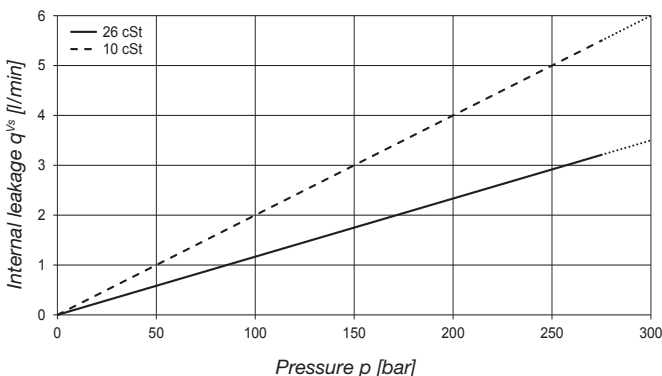

Do not operate pump more than 5 seconds at any speed or viscosity if internal leakage is higher than 50% of theoretical flow.

Noise level (Typical)  
T7A - T7AS - E20

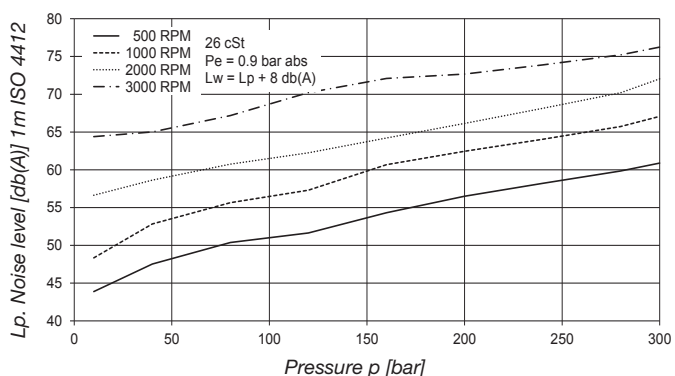

Power loss hydromechanical (Typical)

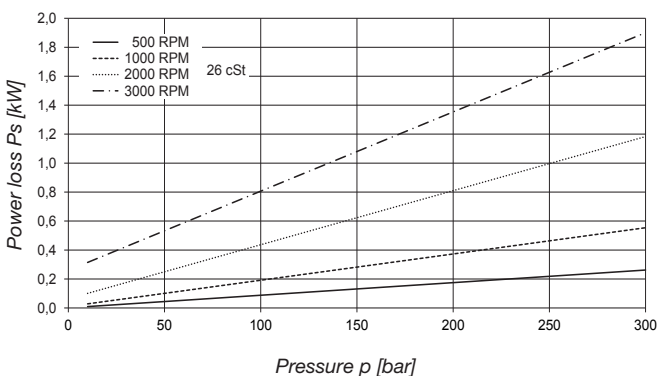

Torque loss hydromechanical (Typical)

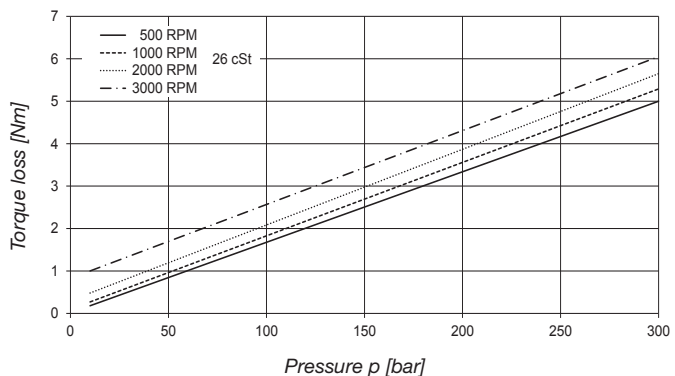

Permissible radial load

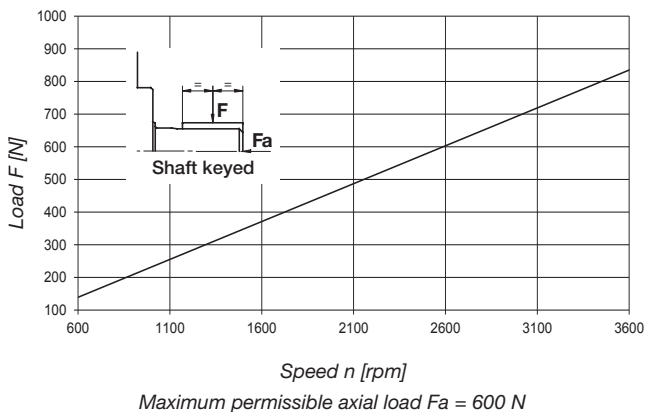

Pump information

Pump type : T7A - T7AS  
Weight : 9,5 kg  
Moment of inertia : 2,6 Kg<sup>m</sup> x 10<sup>-4</sup>  
Input torque limit :

Shaft	Vi [cm <sup>3</sup> /rev] x p max. [bar]	Nm
1	8720	138
2	8720	138
3	8720	138
4	6550	104

**T7ASW**

**Internal leakage (Typical)**

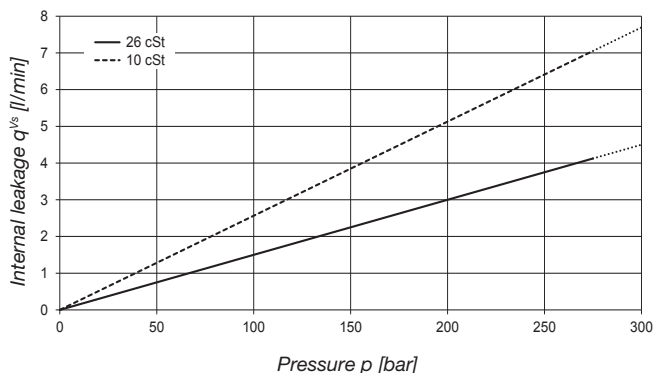

Do not operate pump more than 5 seconds at any speed or viscosity if internal leakage is higher than 50% of theoretical flow.

**Noise level (Typical)  
T7ASW - E40**

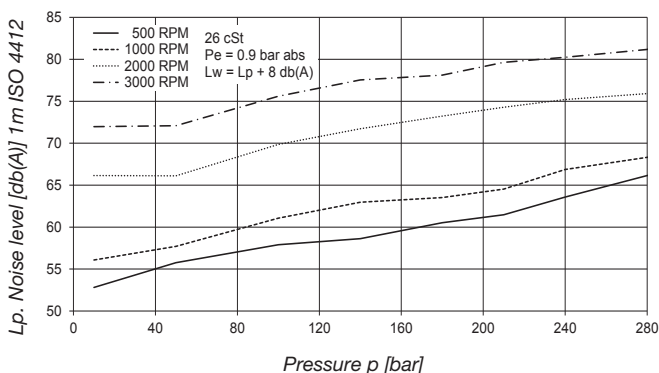

**Power loss hydromechanical (Typical)**

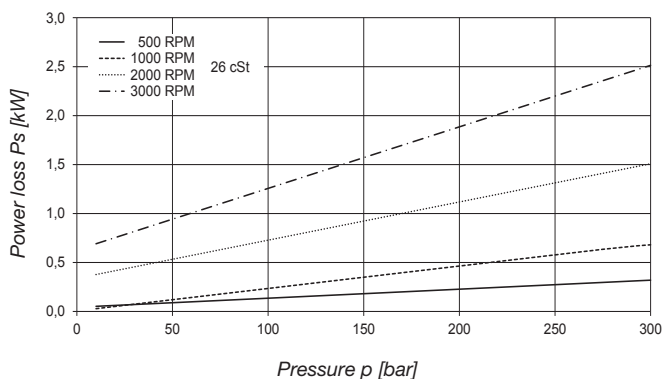

**Torque loss hydromechanical (Typical)**

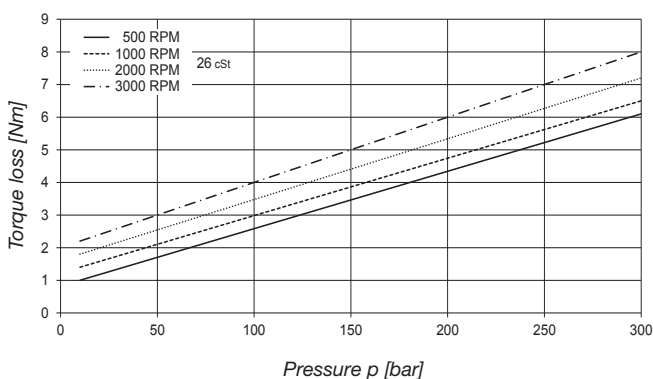

**Permissible radial load**

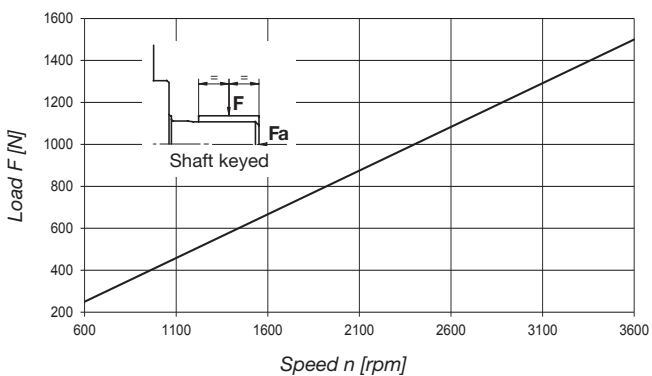

Maximum permissible axial load Fa = 800 N

**Pump information**

**Pump type :** T7ASW  
**Weight :** 11,3 kg  
**Moment of inertia :** 3,2 Kg<sup>m</sup> x 10<sup>-4</sup>  
**Input torque limit :**

Shaft	Vi [cm <sup>3</sup> /rev] x p max. [bar]	Nm
1	18530	294
3	18530	294
X	6550	104

T7B - T7BS

Internal leakage (Typical)

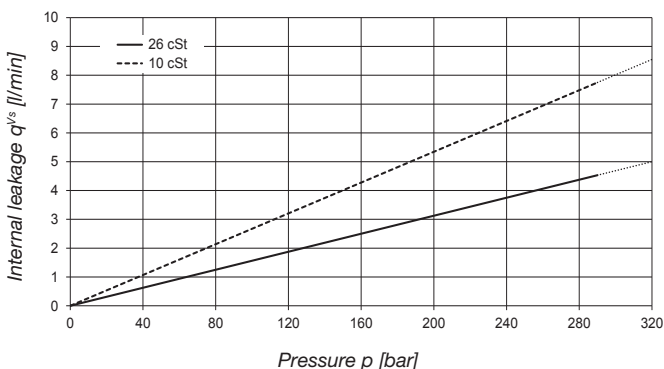

Do not operate pump more than 5 seconds at any speed or viscosity if internal leakage is higher than 50% of theoretical flow.

Noise level (Typical)  
T7B - T7BS - E10

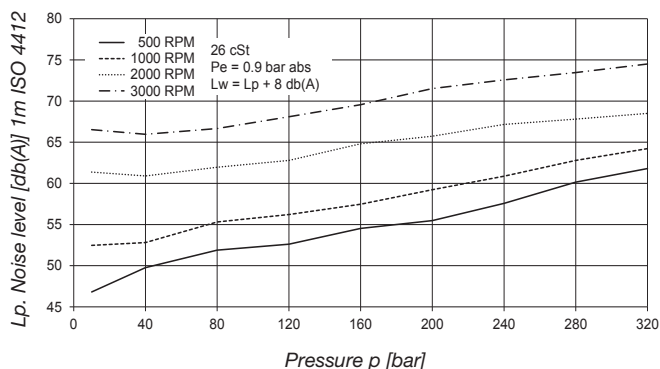

Power loss hydromechanical (Typical)

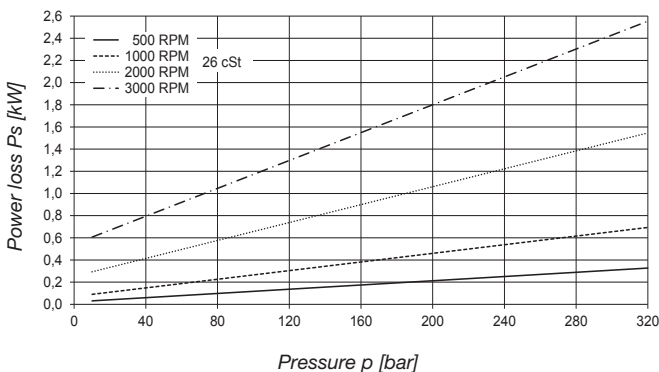

Torque loss hydromechanical (Typical)

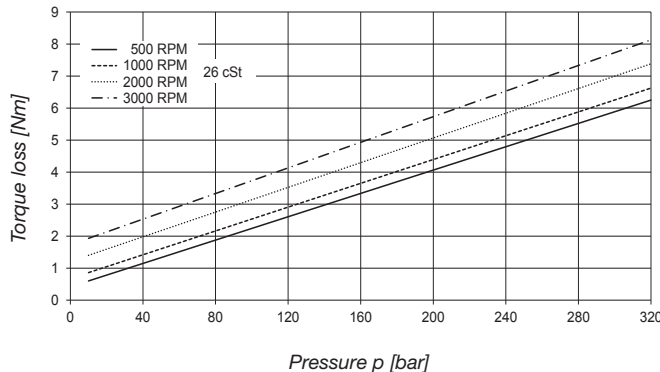

Permissible radial load

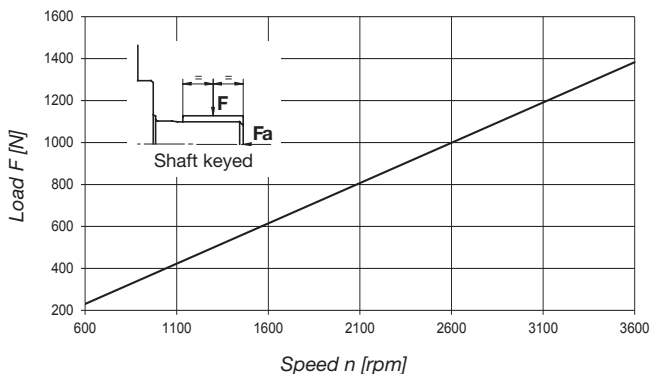

Maximum permissible axial load  $F_a = 800$  N

Pump information

Pump type : T7B - T7BS  
Weight : 23,0 kg  
Moment of inertia :  $3,2 \text{ Kg} \cdot \text{m}^2 \times 10^{-4}$   
Input torque limit :

Shaft	$V_i$ [cm <sup>3</sup> /rev] x p max. [bar]	Nm
1	16500	262
2	20600	327
3	20600	327
4	20600	327

T7D - T7DS

Internal leakage (Typical)

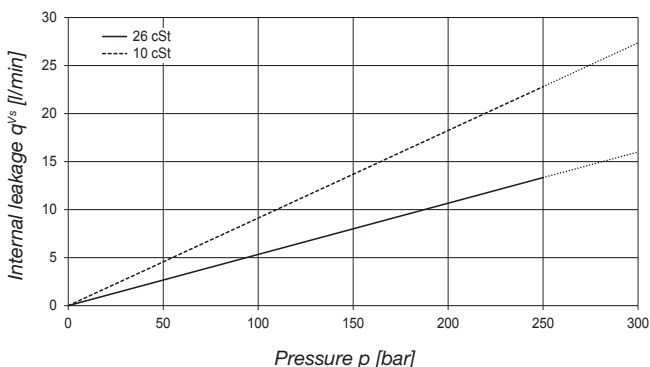

Do not operate pump more than 5 seconds at any speed or viscosity if internal leakage is higher than 50% of theoretical flow.

Noise level (Typical)  
T7D - T7DS - E38

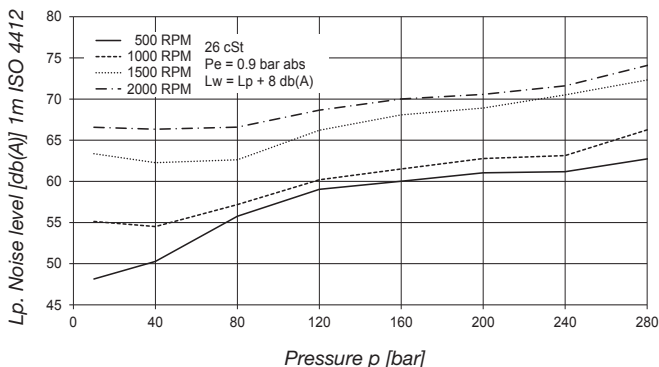

Power loss hydromechanical (Typical)

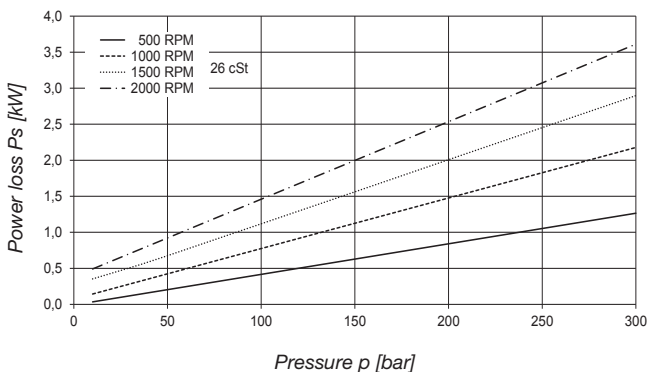

Torque loss hydromechanical (Typical)

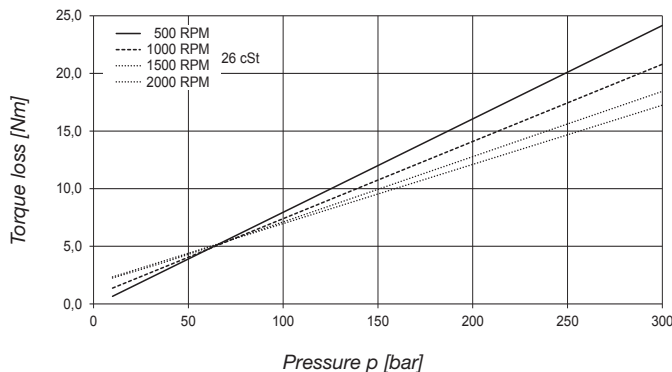

Permissible radial load

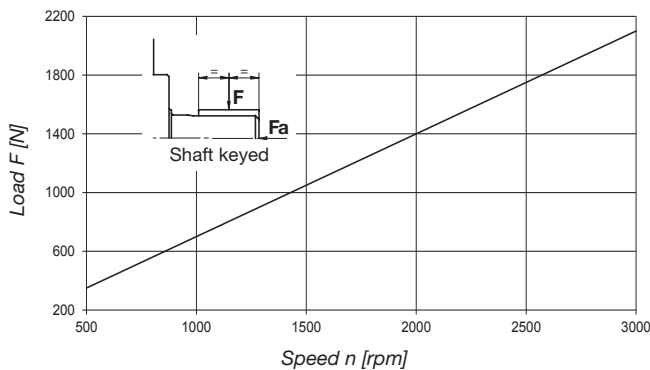

Pump information

Pump type : T7D - T7DS  
Weight : 26,0 kg  
Moment of inertia :  $19,6 \text{ Kg} \cdot \text{m}^2 \times 10^{-4}$   
Input torque limit :

Shaft	$V_i \text{ [cm}^3/\text{rev]} \times p \text{ max. [bar]}$	Nm
1	43240	688
3	61200	974
5	44300	705

T7BB - T7BBS

Internal leakage (Typical)

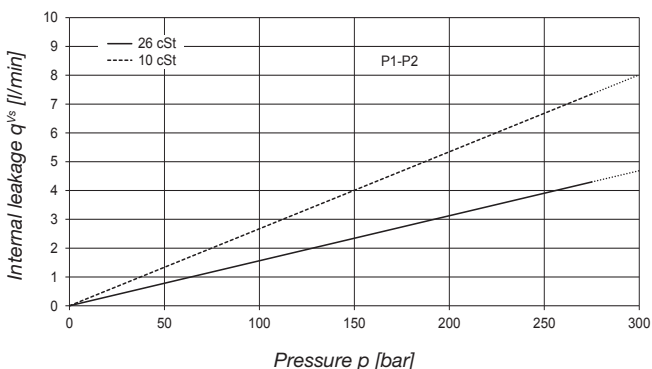

Do not operate pump more than 5 seconds at any speed or viscosity if internal leakage is higher than 50% of theoretical flow. Total leakage is the sum of each section loss under its respective operating conditions.

Noise level (Typical)  
T7BB - T7BBS - E10 - E08

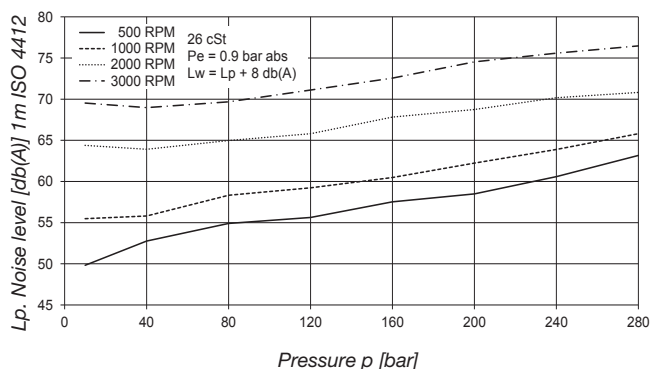

Double pump noise level is given with both stages discharging at the pressure value indicated on the curve.

Power loss hydromechanical (Typical)

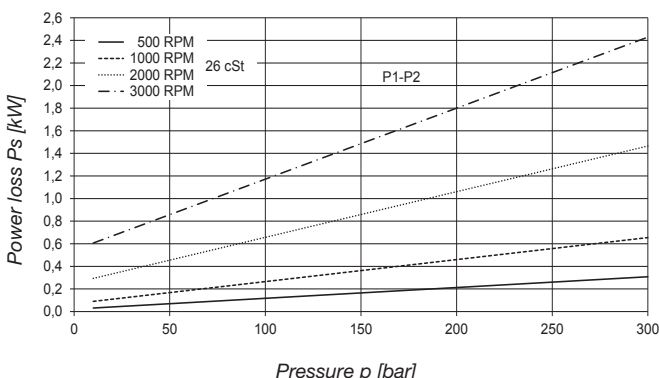

Total hydromechanical power loss is the sum of each section loss under its respective operating conditions.

Torque loss hydromechanical (Typical)

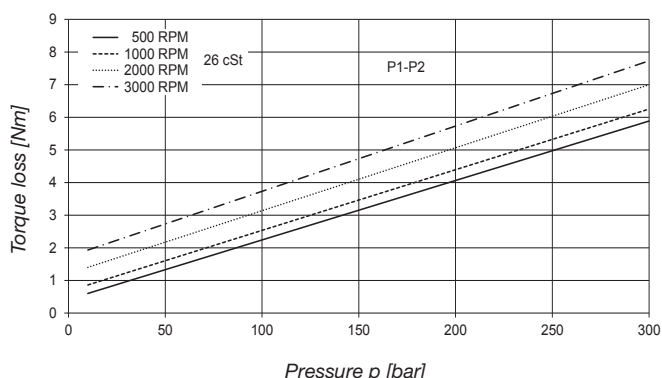

Permissible radial load

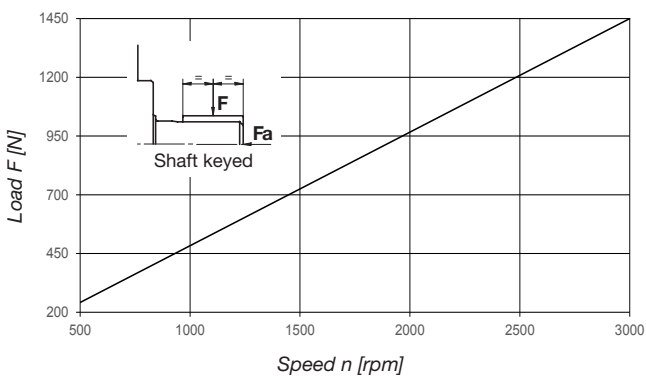

Maximum permissible axial load Fa = 1200 N

Pump information

**Pump type :** T7BB - T7BBS  
**Weight :** 32,6 kg  
**Moment of inertia :** 6,7 Kg<sup>m</sup> x 10<sup>-4</sup>  
**Input torque limit :**

Shaft	Vi [cm <sup>3</sup> /rev] x p max. [bar]	Nm
2	21420	340
3	20600	327
5	25300	402

T7DB - T7DBS

Internal leakage (Typical)

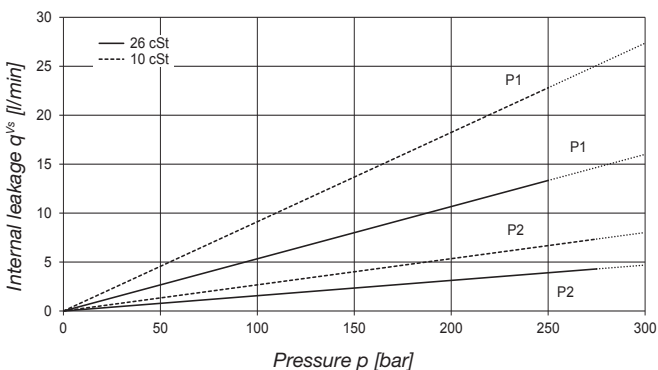

Do not operate pump more than 5 seconds at any speed or viscosity if internal leakage is higher than 50% of theoretical flow. Total leakage is the sum of each section loss under its respective operating conditions.

Noise level (Typical)  
T7DB - T7DBS - E38 - E10

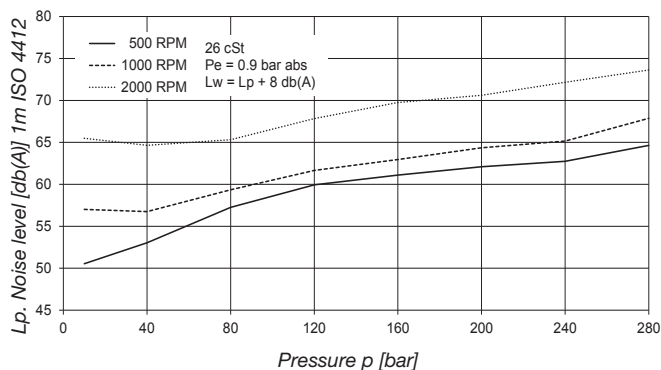

Double pump noise level is given with both stages discharging at the pressure value indicated on the curve.

Power loss hydromechanical (Typical)

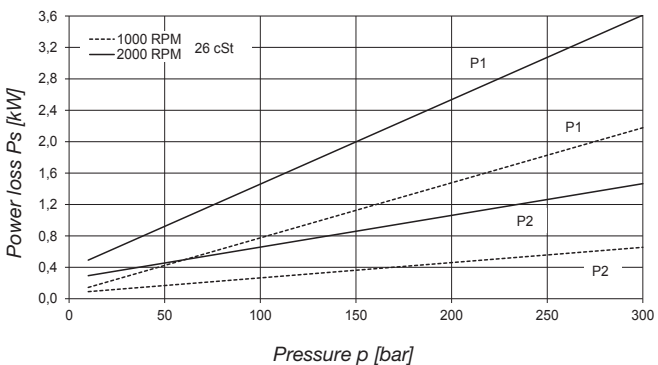

Total hydromechanical power loss is the sum of each section loss under its respective operating conditions.

Torque loss hydromechanical (Typical)

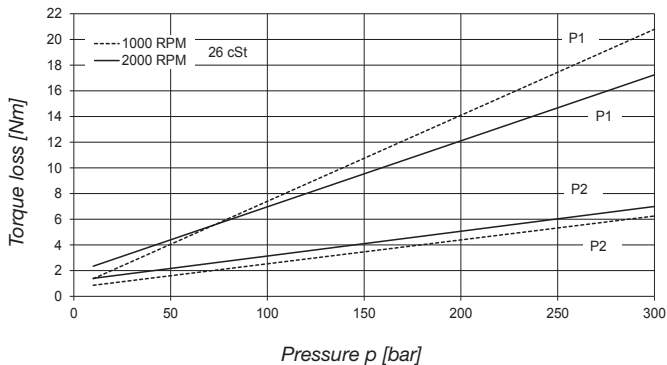

Permissible radial load

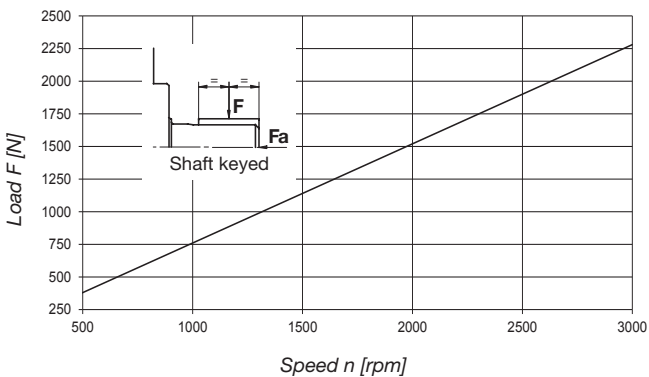

Maximum permissible axial load Fa = 1200 N

Pump information

Pump type : T7DB - T7DBS  
 Weight : 38,6 kg  
 Moment of inertia : 22,7 Kg<sup>m2</sup> x 10<sup>-4</sup>  
 Input torque limit :

Shaft	Vi [cm <sup>3</sup> /rev] x p max. [bar]	Nm
1	43240	688
3	61200	974
5	42500	676

T7DD - T7DDS

Internal leakage (Typical)

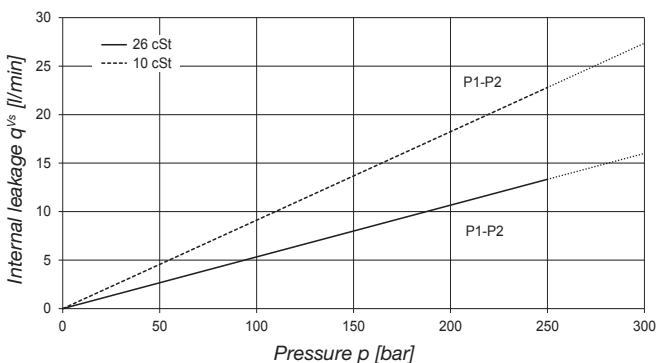

Do not operate pump more than 5 seconds at any speed or viscosity if internal leakage is higher than 50% of theoretical flow.  
Total leakage is the sum of each section loss under its respective operating conditions.

Noise level (Typical)  
T7DD - T7DDS - E38 - E38

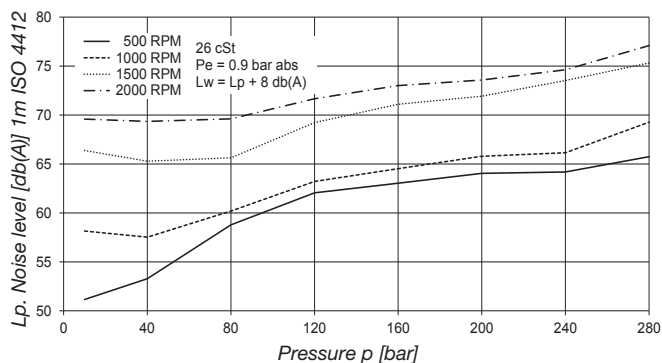

Double pump noise level is given with both stages discharging at the pressure value indicated on the curve.

Power loss hydromechanical (Typical)

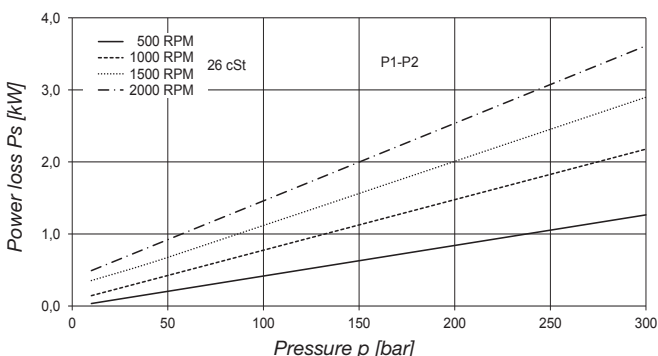

Total hydromechanical power loss is the sum of each section loss under its respective operating conditions.

Torque loss hydromechanical (Typical)

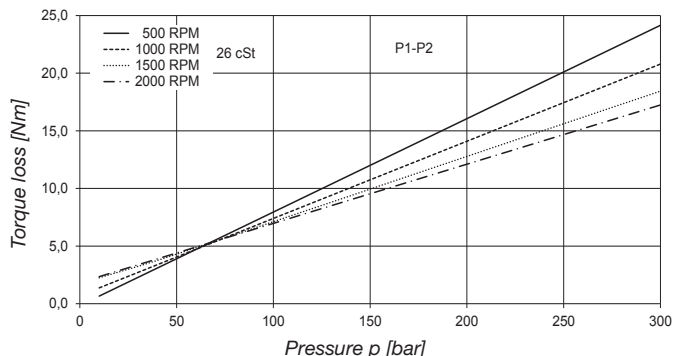

Permissible radial load

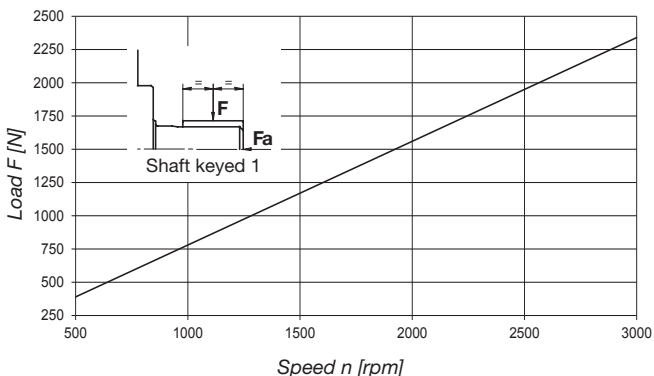

Maximum permissible axial load  $F_a = 1200\text{ N}$

Pump information

Pump type : T7DD - T7DDS  
Weight : 56,0 kg  
Moment of inertia :  $36,3\text{ Kg}\cdot\text{m}^2 \times 10^{-4}$   
Input torque limit :

Shaft	$V_i\text{ [cm}^3\text{/rev]} \times p\text{ max. [bar]}$	Nm
1	43240	688
2	71750	1142
3	61200	974
4	35880	571
5	45200	719

**Pump Selection****Pump selection example****1 The starting point is to collect the hydraulic parameters of the machine cycle :**

The fluid type. The duration, the pressure and the flow values.

Example: The fluid is ISO VG32 mineral oil, and the cycle described in a table.

**2 Calculate the total time of the cycle and the average pressure of the cycle**

Total cycle time =  $\sum_{i=1}^N t_i = 0,6 + 0,3 + 1,5 + 1 + 6,5 + 0,3 + 0,6 + 1 = 11,8$  seconds

Average pressure =  $\frac{\sum_{i=1}^N (p_i \cdot t_i)}{\sum_{i=1}^N t_i}$   
 $((110 \times 0,6) + (140 \times 0,3) + (155 \times 1,5) + (110 \times 1) + (105 \times 6,5) + (155 \times 0,3) + (110 \times 0,6) + (50 \times 1)) / 11,8 = 110$  bar

**3 First estimation of the pump size based on the flow requirement and a "median Max speed".**

Biggest flow requirement = 95 lpm      Median Max speed = 2500 rpm

⇒  $95/2500 \times 1000 = 38$  cm<sup>3</sup>/rev

**4 From the catalogue tables, select a pump that can operate with the fluid type of the application at the max pressure and the Median Max speed.**

Fluid is HF0- HF2 Mineral oil      p max = 155 bar

Median Max speed = 2500 rpm      See speed and pressure ratings in the main technical data tables.

⇒ Let's try a T7B E11 pump with  $V_i = 35$  cm<sup>3</sup>/rev which seems to be acceptable

**5 Report the flow loss of this pump for each working pressure.**

Read T7B flow losses from graphs page 27

- Use 26 or 10 cSt curve depending on the working conditions.

- An average value of the two curves may also be selected

**6 Calculate the real flows the pump has to supply for each step of the cycle.**

Q real. = Q + q<sup>vs</sup>

**7 Calculate the pump rotation speed for each step of the cycle.**

$n = Q \text{ real} \times (10^3 / V_i)$

**8 Calculate the theoretical torque for each step of the cycle.**

T theo. =  $(V_i \times p) / (20 \times \pi)$

**9 Report the torque loss of this pump for each working pressure and operating speed.**

Read T7B torque losses from graph page 27

**10 Calculate the real torque requirement for each step of the cycle.**

T real. = T theo. + T loss.



**Pump Selection**

**11 Compare the torque requirements to the maximum input torque of the selected pump.**

Maximum input torque for T7B E11 pump with shaft type 2 : Read the technical data on page 27.

$T_{max} = 327 \text{ Nm}$

$T_{max}$  must be highest than the larger of  $T_{real}$  value.

If not, select another pump with a stronger shaft and re start from point 2.

**12 Compare the highest rotation speed of the pump during the cycle with the maximum speed rating of the selected pump.**

Maximum speed rating of the T7B E11 pump (read the main technical data on page 4) = 3400 rpm.

Maximum speed in cycle = 2800 rpm.

Maximum speed during cycle must be lower than the maximum speed rating of the pump.

If not, select another pump with a higher speed rating or a bigger displacement and re start from point 2.

**13 For each cycle step, identify the step operating mode in the pump operating range chart.**

Cross pump pressure and speed values on the T7B E11 "pump operating range" chart page 9 : Continuous or Intermittent.

**14 For each Intermittent cycle step, verify that the flow requirement Q is acceptable for the respective step duration t.**

Read the max possible time duration value in "the time restriction at low flow" chart.

In case the step is not Acceptable, correct the Q value to get an Acceptable cycle step.



T7B E11 $v_i = 35 \text{ cm}^3/\text{rev}$	Time $t$ [sec]	Pressure $p$ [bar]	Flow $Q$ [l/min]	Pump losses $q^{vs}$ [l/min]	Supply flow $Q_{real}$ [l/min]	Pump speed $n$ [rpm]	T theo. torque [Nm]	T loss. @ $p$ & rpm [Nm]	T real. torque [Nm]	Operating mode	Cycle step status
Mould close	0,6	110	70	2,0	72,0	2050	61,3	3,5	65	C	A
Tonnage	0,3	140	50	2,2	52,2	1500	78,0	4,0	82	C	A
Injection	1,5	155	95	2,8	97,8	2800	86,4	5,0	92	C	A
Injection hold	1,0	110	16	2,0	18,0	500	61,3	2,5	64	C	A
Curing	6,5	105	90	2,0	92,0	2650	58,5	4,0	63	C	A
Decompression	0,3	155	40	2,8	42,8	1250	86,4	4,0	91	C	A
Mould open	0,6	110	50	2,0	52,0	1500	61,3	3,0	65	C	A
Ejection	1,0	50	30	1,0	31,0	900	27,9	2,0	30	C	A
<b>Total cycle</b>	<b>11,8</b>										
<b>Average cycle pressure</b>		<b>110</b>									

**The preselection of the pump is now complete.**

It is a preselection only as it is now time to find a suitable electric motor to match with the application parameters, and this may lead to reconsider this preselected pump. For the best choice being the best compromise, it may also happen to change the displacement of the preselected pump at the time to fine tune the new complete system.

Parker is also offering a broad range of assembled Drive Controlled Pump systems. In order to easily select these Drive Controlled Pump packages, Parker offers a unique software tool : The DriveCreator. Please consult your local Parker office.

**Pump Selection**

**How to use the time restriction tables**

**1 Graph for pump type T7B E15 : Vi = 50 cm³/rev**

Step time duration : 300 sec  
 Pressure : 160 bar  
 Needed output flow : 4 l/mn  
 Continuous Zone = No time restriction

This cycle step is acceptable with  
 Pump Min speed =  $(Q + q^{vs}) \times (10^3 / V_i)$

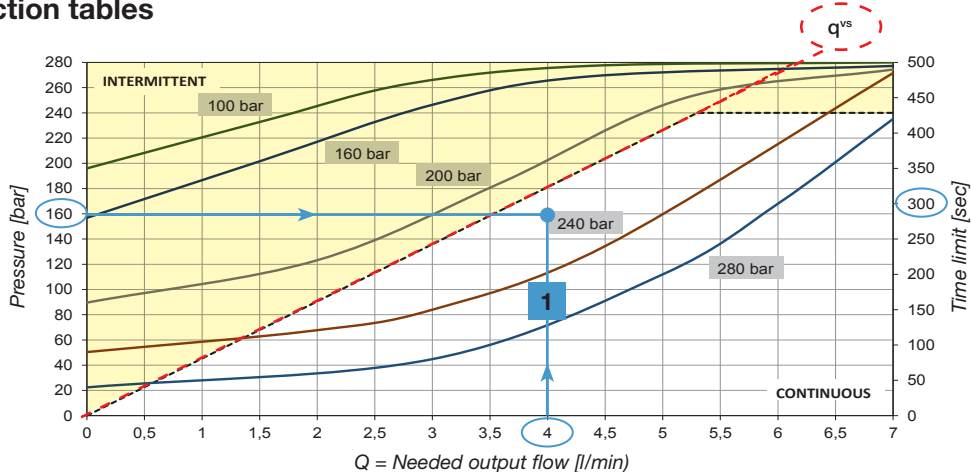

**2 Graph for pump type T7B E15 : Vi = 50 cm³/rev**

Step time duration : 180 sec  
 Pressure : 200 bar  
 Needed output flow : 3,5 l/mn  
 Intermittent Zone = Time restriction  
 Read time restriction value for 200 bar curve

T Max = 325 > 180 sec

This cycle step is acceptable with  
 Pump Min speed =  $(Q + q^{vs}) \times (10^3 / V_i)$

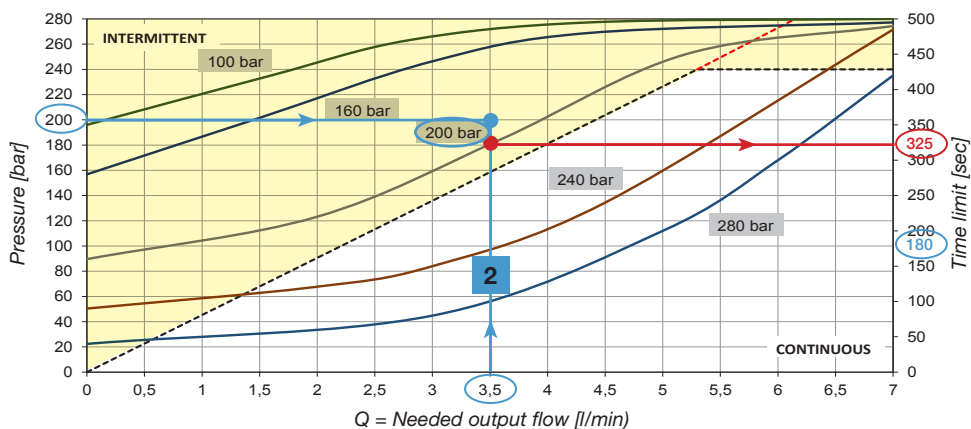

**3 Graph for pump type T7B E15 : Vi = 50 cm³/rev**

Step time duration : 400 sec  
 Pressure : 200 bar  
 Needed output flow : 3,5 l/mn  
 Intermittent Zone = Time restriction  
 Read time restriction value for 200 bar curve

T Max = 325 < 400 sec

**This cycle step is not acceptable**  
 An additional flow amount must be added in order to perform this step.

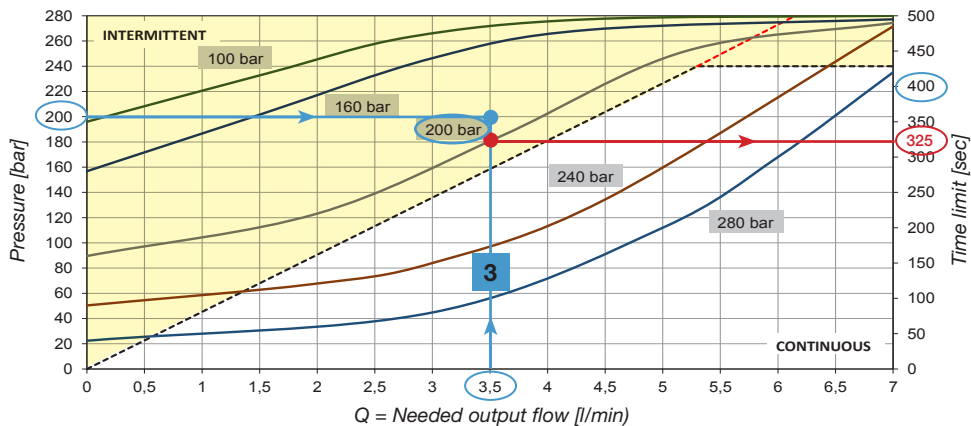

**4 Graph for pump type T7B E15 : Vi = 50 cm³/rev**

Step time duration : 400 sec  
 Pressure : 200 bar  
 Needed output flow : ?  
 Read on the 200 bar curve the needed flow value

allowing more than 400 sec : 5 l/mn

This cycle step is acceptable with  
 Pump Min speed =  $(Q + q^{vs}) \times (10^3 / V_i)$

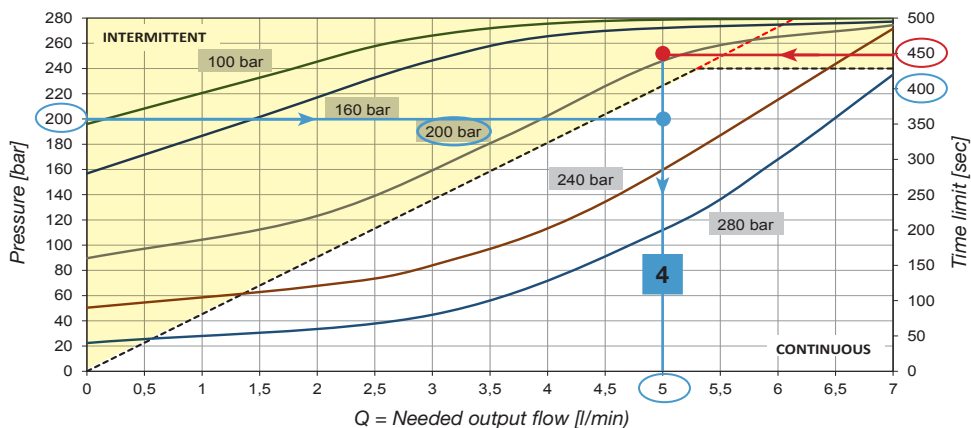

**Time restriction at low flow**

**T7A - T7AS  
E06 - E10 - E11 - E13**

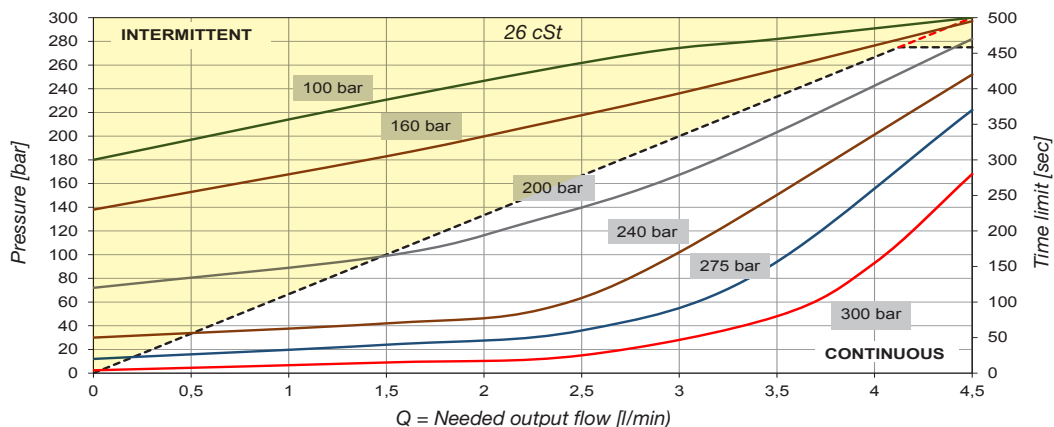

**T7A - T7AS  
E17 - E20 - E22**

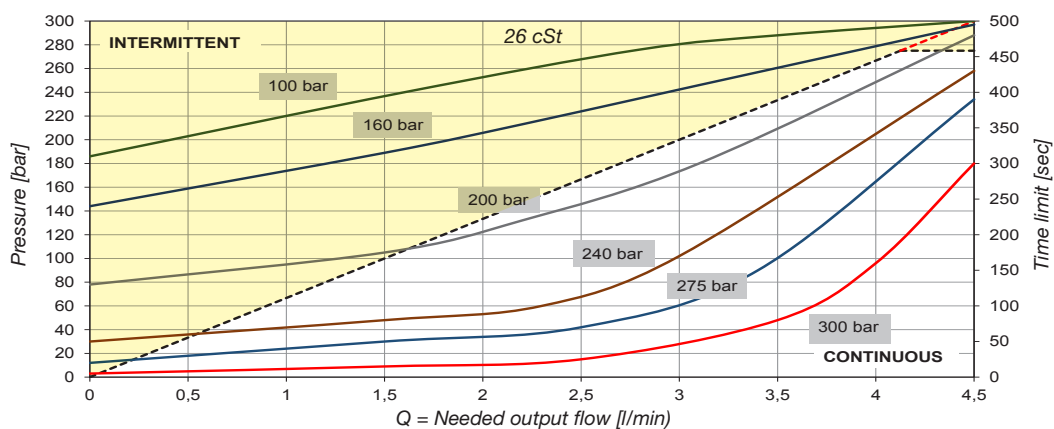

**T7A - T7AS  
E25**

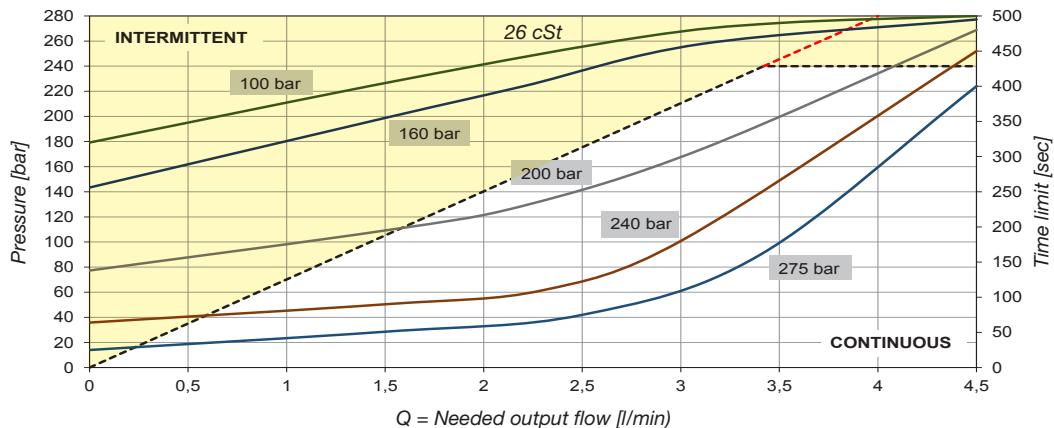

**Pump Selection**

**Time restriction at low flow**

**T7ASW  
 E22 - E26 - E28**

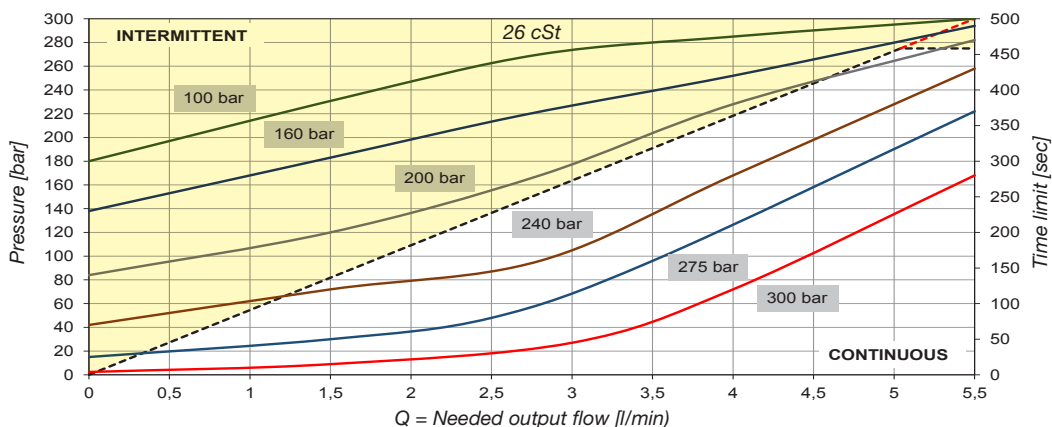

**T7ASW  
 E30 - E32**

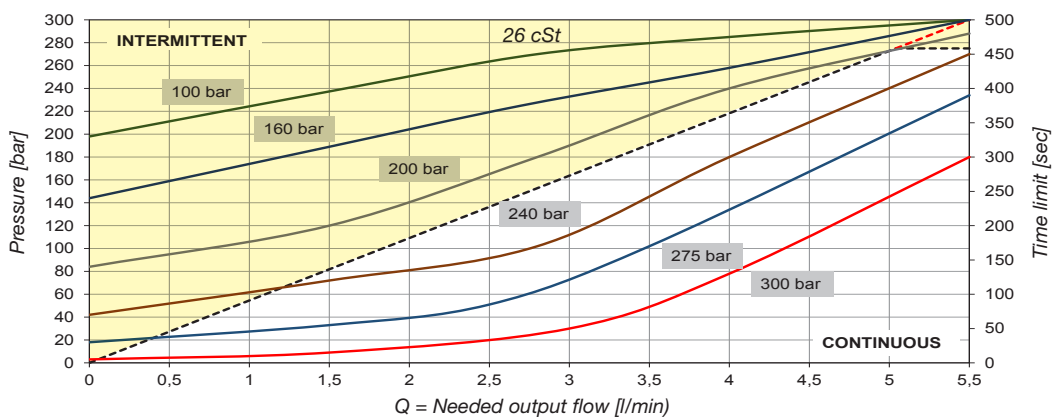

**T7ASW  
 E35 - E36 - E40**

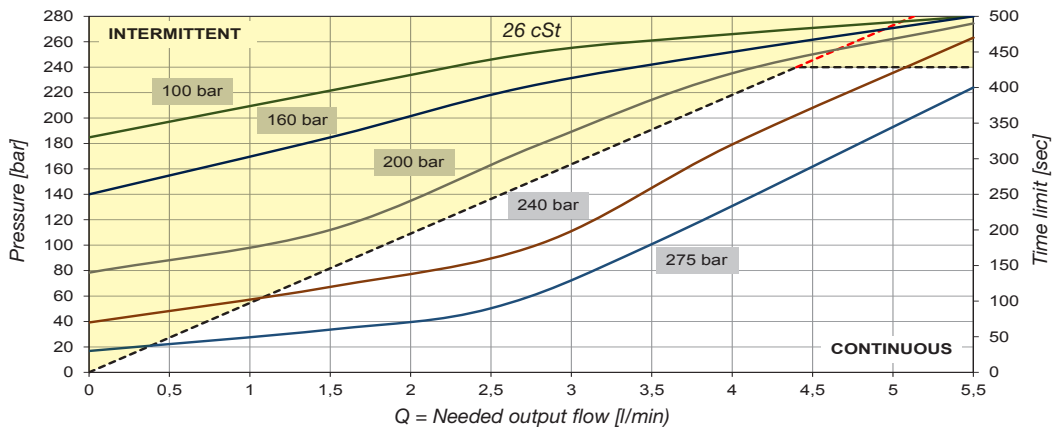

**Time restriction at low flow**

**T7B - T7BS  
E03 - E04 - E05 - E06**

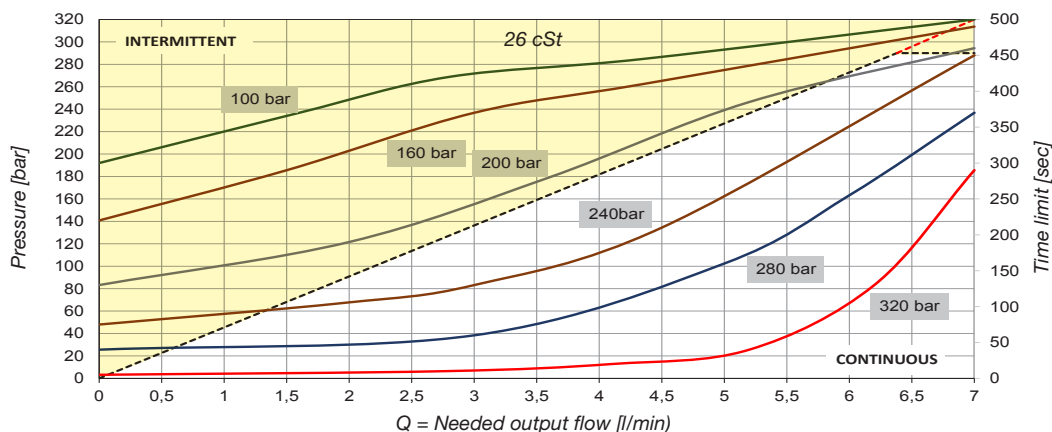

**T7B - T7BS  
E07 - E08 - E09 - E10**

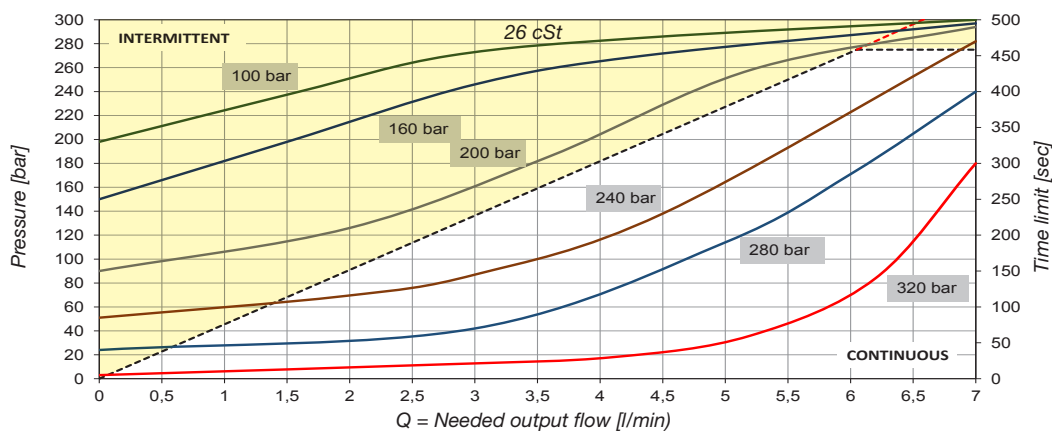

**T7B - T7BS  
E11 - E12 - E14**

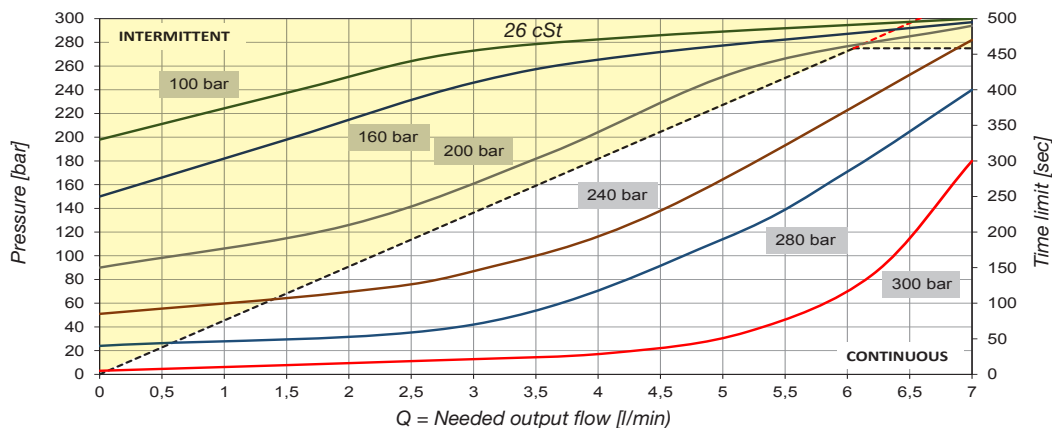

**T7B - T7BS  
E15**

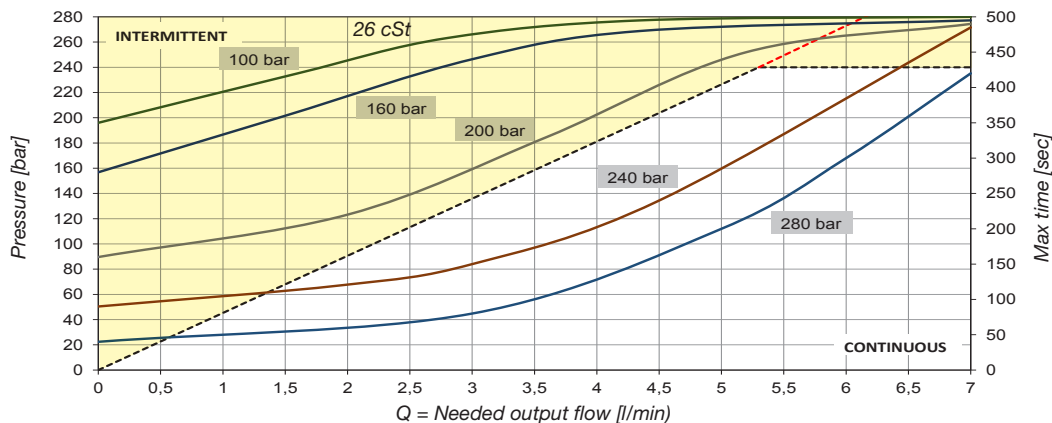

**Pump Selection**

**Time restriction at low flow**

**T7D - T7DS  
 E14 - E17 - E20**

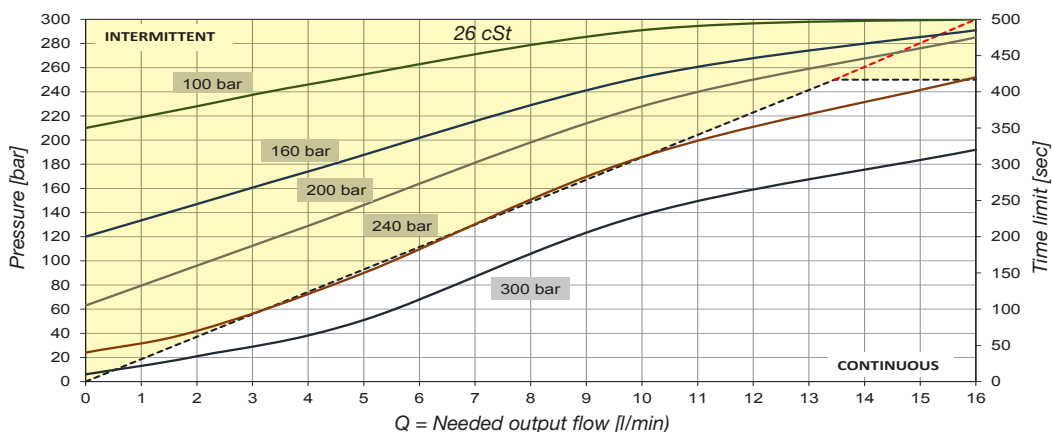

**T7D - T7DS  
 E22 - E24 - E28 - E31**

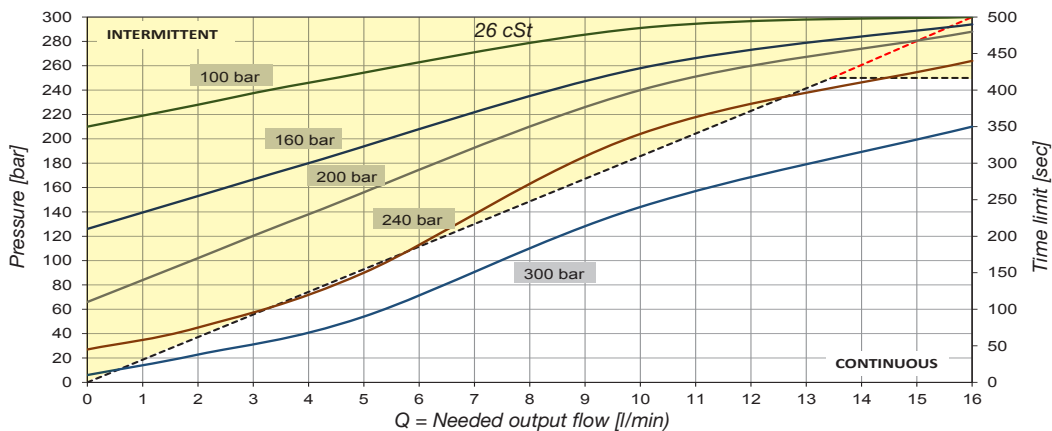

**T7D - T7DS  
 E35 - E38**

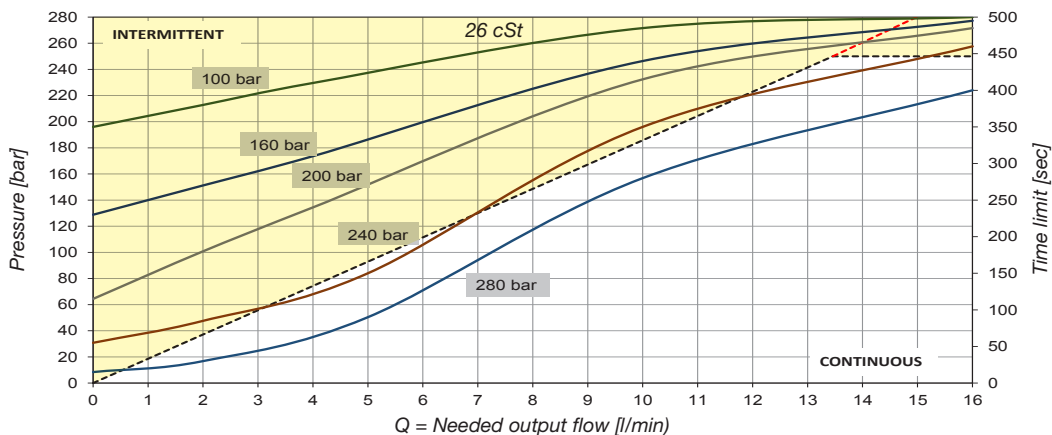

**T7D - T7DS  
 E42**

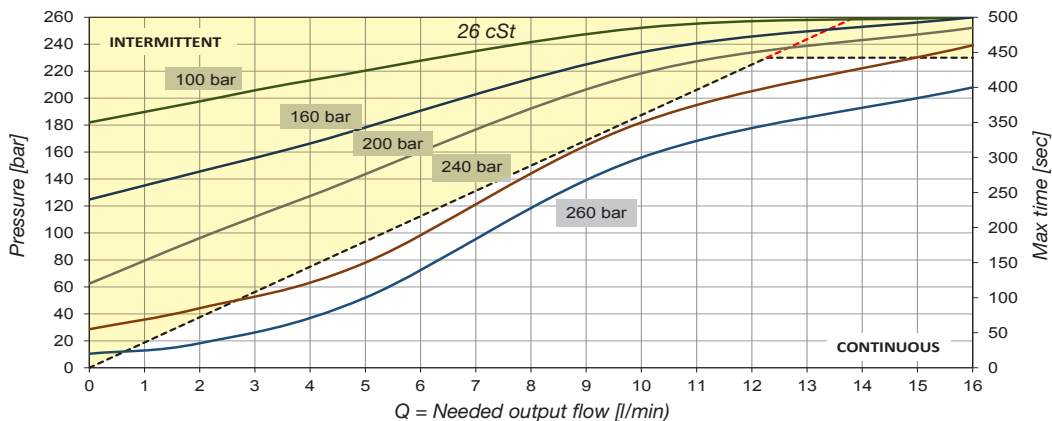

**Circuit design**

**Holding the pressure**

When a high pressure has to be held over a long period of time, the design of the hydraulic circuit must be carefully considered. If the pressure has to be held more than 10 minutes, a hydraulic circuit with an accumulator may be energywiser.

**Pressure hold function in Flow control mode**

To improve the energy efficiency of the system, the rotation speed of the pump is usually reduced during the pressure holding steps. Depending on the pressure value that needs to be held, the rotation speed of the pump can be reduced down to its corresponding minimum.

**Specific Circuit design for operating in pressure control mode**

Operating a pump with a variable speed drive in pressure control mode requires the hydraulic circuit to be designed taking the following points into account.

- A pressure relief valve is still needed as a safety device.
- A bypass line must be included in the hydraulic circuit. It will provide the necessary cooling flow for the pump and help in stabilizing the fluid viscosity in order to achieve a stable pressure regulation. The bypass line can be activated by an on/off directional control valve when the system is above a certain pressure value and below a certain speed value.

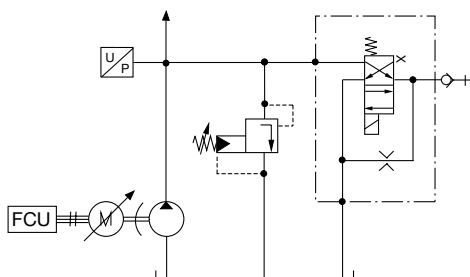

Example of bypass line circuitry :  
The size of the orifice is depending on the maximum pressure value to be regulated, and the pump type.

Determination of the necessary bypass flow:  $Q_{Bypass@p} = q^{vs} + Q_{Syst}$

$q^{vs}$  : internal flow loss of the pump at the operating pressure p.

$Q_{Syst}$  : flow amount that is necessary to compensate the leakages of the actuators and valves, and to compress the oil volume.

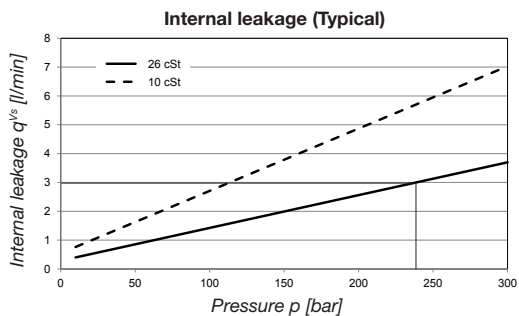

Example: Pump T7B E09 operating at p = 240 bar  
ISO VG32 mineral oil at approx 45°C

$V_{i,T7B E09} = 28 \text{ cm}^3/\text{rev}$

Estimation based on the circuit design,  $Q_{Syst} = 1 \text{ lpm}$

Value Read from the T7B technical data page,  $q^{vs} = 3 \text{ lpm}$

$Q_{Bypass@p} = 3 + 1 = 4 \text{ lpm}$

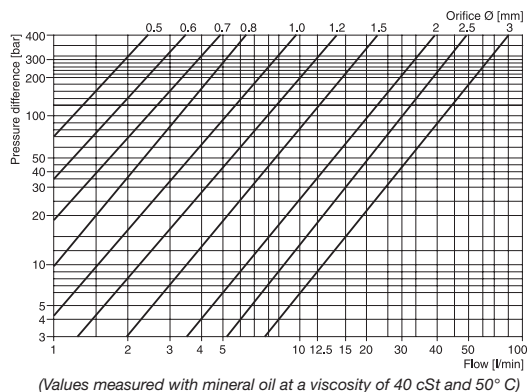

Estimation of the orifice diameter to get at least 4 lpm at 240 bar

$\Rightarrow \text{Ø } 0,7 \text{ mm}$

**Circuit Design**

**Decompression :**

The T7 pumps for variable speed drives may be operated in a 2 quadrant mode:

- Pump mode : flow is going from the "S" to the "P" port
- Motor mode : flow is going from the "P" to the "S" port

The Rotation way described in the pump model description is corresponding to the pump mode. Never install a check valve on the "P" discharge line of the pump when a reverse rotation way is enabled.

Special care has to be taken for the transition between cycle steps, in particular for the switch of the directional control valves. When operating the pump in pressure control mode, this is of the utmost importance. In this case, the pressure set value must be ramped down before switching to flow control mode and then energizing the directional control valve.

The technology of the T7 pumps for variable speed drives is allowing a quick natural decompression of the pressure line without the need to reverse the rotation way of the E motor. Only very fast cycling machines may require to reverse the rotation way in order to decompress the pressure line in a very short time. In such a case, care must be taken that the pressure line remains positive at all time as to avoid any cavitation noise and wear to occur. Negative speed values in the range of -500 rpm could be considered.

**Dynamic characteristics**

The dynamic characteristic of a hydraulic system is depending on many parameters, the hydraulic pump being only one of these. This is why it is not possible in a pump catalogue to indicate precise dynamic values. We would like however to point out the following :

- The moment of inertia of the pump is mentioned on its data page of this catalogue.
- In flow control mode, the pump response time will be depending on the dynamic performances of the electric motor used, its drive unit and the oil circuitry. Flow response times in the same range or shorter than variable displacement load sensing pumps are achievable.
- When assembled to servo motors, fast drives and fast sensors, our pumps are allowing a closed loop pressure control suitable for many applications.

**Example :**

- Fluid : 26 cSt Mineral oil
- Pump : T7B E14
- Servomotor : MH 265 Series
- Control loop system :
  - Closed loop pressure control
  - Closed loop speed control
  - Closed loop motor torque control

**UP**  
 Acceleration from 100 to 2500 rpm  
 Pressure rise from 10 to 140 bar

**DOWN**  
 Depressurization from 140 to 10 bar  
 Deceleration from 2500 to 100 rpm

- Inlet line : 1.1/2"
- Inlet line : 600 mm long and flooded
- Discharge line : 1"
- Discharge length : 1200 mm

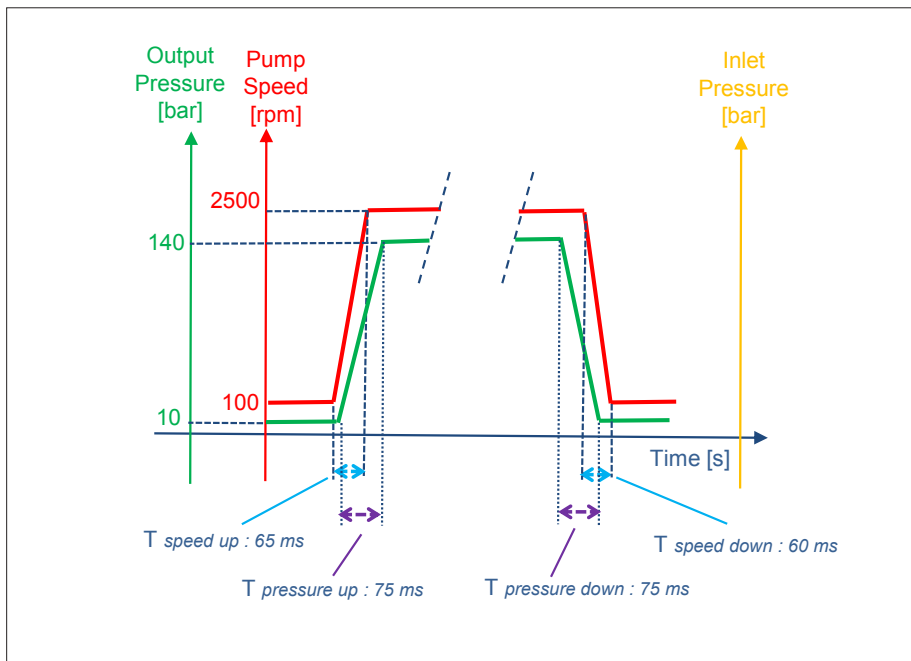



## Pump installation

### Pump mounting

The environment of the pump has to be taken into consideration as to avoid noise reflection, pollution and shocks. These pumps are designed to operate in any position. Always prefer an installation with a flooded inlet or with the pump inside the oil tank.

The installation of the pump on the top of the tank should be restricted to the operation in Flow Mode with moderate dynamic requirements. In such a case the inlet pipe of the pump must be sized according to the max discharge flow in order to keep the inlet velocity below 1,5 m/s.

d [mm] Inner diameter of the inlet pipe or hose  
v [m/s] Average velocity  
Q [L/min] Inlet flow

$$d = \sqrt{\frac{400}{6\pi} \cdot \frac{Q}{v}} \approx 4.61 \cdot \sqrt{\frac{Q}{v}}$$

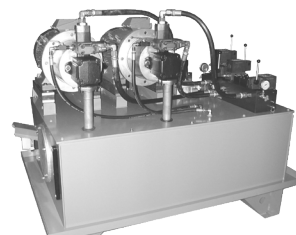
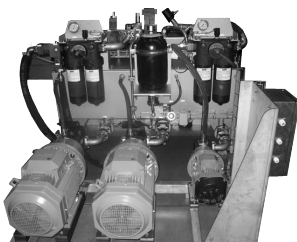
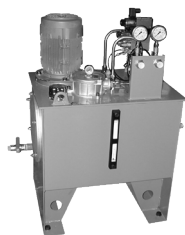

### Shaft and coupling data

- **Shaft loads** : These products are primarily designed for coaxial drives which do not impose axial or side loading on the shaft. The max. permissible load values are indicated on the pump technical data page. Contact Parker for specific applications.

- **Keyed shafts** : Parker supplies its keyed shaft pumps with high strength heat-treated keys. Therefore, when installing or replacing these pumps, the heat-treated keys must be used in order to ensure maximum life in the application. If the key is replaced, it must be a heat-treated key between 27 and 34 R.C. hardness. The corners of the keys must be chamfered by 0,76 mm to 1,02 mm (0.03 to 0.04) at 45° to clear the radii in the key way.

The alignment of the keyed shafts must be within the tolerances given for the splined shafts here below.

- **Couplings and female splines** : The coupling must be selected to minimize the load on the shaft (weight, misalignment).

The female spline must be made to conform to the Class 1 fit as described in SAE-J498b (1971). This is described as a Flat Root Side Fit.

The mating female spline should be free to float and find its own center. If both members are rigidly supported, they must be aligned within 0,15 TIR (0.006" TIR) or less to reduce fretting. The angular alignment of two splines axes must be less than ± 0,05 per 25,4 radius (± 0.002" per 1" radius).

The coupling must be hardened to a hardness between 29 and 45 HRC.

The coupling spline must be lubricated with a lithium molydisulfide grease, disulfide of molybdenum or a similar lubricant.

### Fluid connections

Keep a maximum distance between the suction pipe and the return lines in the tank. A bevel of min 45° on suction and return lines is recommended in order to lower the fluid velocity.

Fluid lines must be adequate size and strength to assure free flow through the pump. An undersized inlet pipe will prevent the pump from operating properly at full rated speed. An undersized outlet line will cause back pressure, heat generation and noise increase. If the pump is inside the tank, use a short inlet pipe.

Flexible hose lines are recommended. If rigid piping is used, the workmanship must be accurate to eliminate strain on the pump ports or to the fluid connections. Sharp bends in the lines must be eliminated wherever possible. All system piping must be cleaned and flushed before installing the pump.

## Start-up instructions

All Parker vane pumps are individually factory tested to provide the best quality & reliability. They are to be used within the design limits indicated in our documentation. Only qualified personnel who is competent and familiar with the installation and operation of hydraulic drives and has hydraulic circuits and hydraulic equipment knowledge is allowed to put the equipment into operation. Make sure to have all necessary documentation available and always conform yourself to the valid regulations (safety, electrical, environment...).

### Rotation way and ports indication

The rotation way and ports orientation are viewed from the shaft end.

CW stands for clockwise = Right-hand rotation.

CCW stands for counter-clockwise = Left-hand rotation.

### Pre-start checks

Before initial starting of the pump, the following checks should be made :

- a. Check the rotation of the power source to be sure the pump shaft will rotate in the direction indicated by the arrow on the pump nameplate.
- b. Check inlet and discharge lines to be sure all connections are tight and properly connected.
- c. Check fluid type, its cleanliness and level. Make sure it can freely reach the pump inlet.

### Filling, air removing & priming

The pressure relief valve should be backed off to its minimum setting value so the pump is unloaded when started. Circuit priming and air bleed off have to be performed before resetting the pressure relief valve. For priming, a minimum pump shaft speed of 600 rpm is recommended. To prevent possible damage to the internal parts, the pump should never be started dry or without internal lubrication.

- Pump with positive head : allow the fluid to flow to the pump inlet, loosen the discharge port(s) fitting(s) until the fluid comes out and re-tighten the discharge line(s). Then start the pump which should prime quite instantly. Purge the air off the circuit, preferably using air bleed off valves or pressure test points. Let the pump discharge several minutes unloaded.

- Pump mounted above fluid level : fill the pump through outlet port(s) with suitable and clean fluid and start rotation in jog mode. Purge the air off the circuit, preferably using air bleed off valves or pressure test points. Let the pump discharge several minutes unloaded.

### Notes

If the pump does not prime properly or pressure cannot be obtained within seconds, it should be shut down and conditions corrected. Refer to the machine/vehicle manufacturer instructions and pump catalogue.

## Maintenance

The pump is self-lubricating and its preventive maintenance is limited to keeping the hydraulic fluid clean and maintaining its viscosity within the acceptable limits. Keep all fittings and screws tight. Do not operate at pressures or speeds in excess of the recommended limits. If the pump does not operate properly, check the troubleshooting chart before attempting to overhaul the unit. The pump is fully serviceable.

**WARNING – USER RESPONSIBILITY**

**FAILURE OR IMPROPER SELECTION OR IMPROPER USE OF THE PRODUCTS DESCRIBED HEREIN OR RELATED ITEMS CAN CAUSE DEATH, PERSONAL INJURY AND PROPERTY DAMAGE.**

This document and other information from Parker-Hannifin Corporation, its subsidiaries and authorized distributors provide product or system options for further investigation by users having technical expertise.

The user, through its own analysis and testing, is solely responsible for making the final selection of the system and components and assuring that all performance, endurance, maintenance, safety and warning requirements of the application are met. The user must analyze all aspects of the application, follow applicable industry standards, and follow the information concerning the product in the current product catalog and in any other materials provided from Parker or its subsidiaries or authorized distributors.

To the extent that Parker or its subsidiaries or authorized distributors provide component or system options based upon data or specifications provided by the user, the user is responsible for determining that such data and specifications are suitable and sufficient for all applications and reasonably foreseeable uses of the components or systems.

**Offer of Sale**

Please contact your Parker representation for a detailed "Offer of Sale".

# Parker Worldwide

## Europe, Middle East, Africa

**AE – United Arab Emirates,**  
Dubai

Tel: +971 4 8127100  
parker.me@parker.com

**AT – Austria,** Wiener Neustadt  
Tel: +43 (0)2622 23501-0  
parker.austria@parker.com

**AT – Eastern Europe,** Wiener  
Neustadt  
Tel: +43 (0)2622 23501 900  
parker.easteurope@parker.com

**AZ – Azerbaijan,** Baku  
Tel: +994 50 22 33 458  
parker.azerbaijan@parker.com

**BE/LU – Belgium,** Nivelles  
Tel: +32 (0)67 280 900  
parker.belgium@parker.com

**BG – Bulgaria,** Sofia  
Tel: +359 2 980 1344  
parker.bulgaria@parker.com

**BY – Belarus,** Minsk  
Tel: +48 (0)22 573 24 00  
parker.poland@parker.com

**CH – Switzerland,** Etoy  
Tel: +41 (0)21 821 87 00  
parker.switzerland@parker.com

**CZ – Czech Republic,** Klecany  
Tel: +420 284 083 111  
parker.czechrepublic@parker.com

**DE – Germany,** Kaarst  
Tel: +49 (0)2131 4016 0  
parker.germany@parker.com

**DK – Denmark,** Ballerup  
Tel: +45 43 56 04 00  
parker.denmark@parker.com

**ES – Spain,** Madrid  
Tel: +34 902 330 001  
parker.spain@parker.com

**FI – Finland,** Vantaa  
Tel: +358 (0)20 753 2500  
parker.finland@parker.com

**FR – France,** Contamine s/Arve  
Tel: +33 (0)4 50 25 80 25  
parker.france@parker.com

**GR – Greece,** Athens  
Tel: +30 210 933 6450  
parker.greece@parker.com

**HU – Hungary,** Budaörs  
Tel: +36 23 885 470  
parker.hungary@parker.com

**IE – Ireland,** Dublin  
Tel: +353 (0)1 466 6370  
parker.ireland@parker.com

**IT – Italy,** Corsico (MI)  
Tel: +39 02 45 19 21  
parker.italy@parker.com

**KZ – Kazakhstan,** Almaty  
Tel: +7 7273 561 000  
parker.easteurope@parker.com

**NL – The Netherlands,** Oldenzaal  
Tel: +31 (0)541 585 000  
parker.nl@parker.com

**NO – Norway,** Asker  
Tel: +47 66 75 34 00  
parker.norway@parker.com

**PL – Poland,** Warsaw  
Tel: +48 (0)22 573 24 00  
parker.poland@parker.com

**PT – Portugal**  
Tel: +351 22 999 7360  
parker.portugal@parker.com

**RO – Romania,** Bucharest  
Tel: +40 21 252 1382  
parker.romania@parker.com

**RU – Russia,** Moscow  
Tel: +7 495 645-2156  
parker.russia@parker.com

**SE – Sweden,** Spånga  
Tel: +46 (0)8 59 79 50 00  
parker.sweden@parker.com

**SK – Slovakia,** Banská Bystrica  
Tel: +421 484 162 252  
parker.slovakia@parker.com

**SL – Slovenia,** Novo Mesto  
Tel: +386 7 337 6650  
parker.slovenia@parker.com

**TR – Turkey,** Istanbul  
Tel: +90 216 4997081  
parker.turkey@parker.com

**UA – Ukraine,** Kiev  
Tel: +48 (0)22 573 24 00  
parker.poland@parker.com

**UK – United Kingdom,** Warwick  
Tel: +44 (0)1926 317 878  
parker.uk@parker.com

**ZA – South Africa,** Kempton Park  
Tel: +27 (0)11 961 0700  
parker.southafrica@parker.com

## North America

**CA – Canada,** Milton, Ontario  
Tel: +1 905 693 3000

**US – USA,** Cleveland  
(industrial)  
Tel: +1 216 896 3000

**US – USA,** Elk Grove Village  
(mobile)  
Tel: +1 847 258 6200

## Asia Pacific

**AU – Australia,** Castle Hill  
Tel: +61 (0)2-9634 7777

**CN – China,** Shanghai  
Tel: +86 21 2899 5000

**HK – Hong Kong**  
Tel: +852 2428 8008

**ID – Indonesia,** Tangerang  
Tel: +62 21 7588 1906

**IN – India,** Mumbai  
Tel: +91 22 6513 7081-85

**JP – Japan,** Fujisawa  
Tel: +81 (0)4 6635 3050

**KR – South Korea,** Seoul  
Tel: +82 2 559 0400

**MY – Malaysia,** Shah Alam  
Tel: +60 3 7849 0800

**NZ – New Zealand,** Mt Wellington  
Tel: +64 9 574 1744

**SG – Singapore**  
Tel: +65 6887 6300

**TH – Thailand,** Bangkok  
Tel: +662 186 7000

**TW – Taiwan,** New Taipei City  
Tel: +886 2 2298 8987

**VN – Vietnam,** Ho Chi Minh City  
Tel: +84 8 3999 1600

## South America

**AR – Argentina,** Buenos Aires  
Tel: +54 3327 44 4129

**BR – Brazil,** Cachoeirinha RS  
Tel: +55 51 3470 9144

**CL – Chile,** Santiago  
Tel: +56 2 623 1216

**MX – Mexico,** Toluca  
Tel: +52 72 2275 4200



### EMEA Product Information Centre

Free phone: 00 800 27 27 5374

(from AT, BE, CH, CZ, DE, DK, EE, ES, FI, FR, IE, IL,  
IS, IT, LU, MT, NL, NO, PL, PT, RU, SE, SK, UK, ZA)

### US Product Information Centre

Toll-free number: 1-800-27 27 537

www.parker.com

Your local authorized Parker distributor